

BIS RapidStrut® Rail Connector 90° G2 (BUP1000)

(H 28 04)

to make Strut rail fabrications



Features and Benefits

- connector with pre-assembled BIS RapidStrut® Slide nut(s)
- to make fabrication with Strut Rail
- ready-to-use pre-assembled for a quick fixing, and retains assembly in place before final tightening
- 'Direct Twist' technology for easy and secure installation
- visual guide to check the position of the slide nut
- Part No. 66588520X: optimized for easy installation with electrical tools
- material: metal parts made of steel 1.0332; spring(s) made of POM (polyoxymethylene), green
- surface protection:
 - product is part of the BIS UltraProtect® 1000 system
 - suitable for in- and outdoor applications
 - stands min. 1,000 hours salt spray test (max. 5% red rust) according to ISO 9227

Part No.	Model	Type	a (°)	T _(max.) (Nm)	For Rail	Pack 1
665885102	Short / short	2 sides pre-assembled	90°	40.0	Strut	50
665885202	Short / short	2 sides pre-assembled	90°	40.0	Strut	50
665885203	Short / long	2 sides pre-assembled	90°	40.0	Strut	25
665885205	Long / long	2 sides pre-assembled	90°	40.0	Strut	20

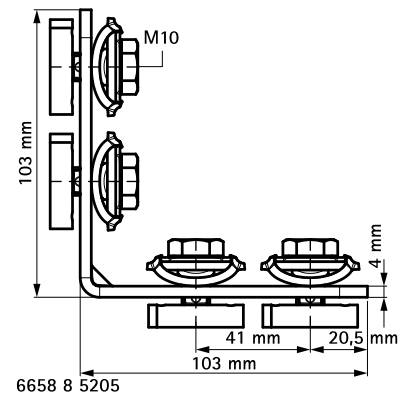
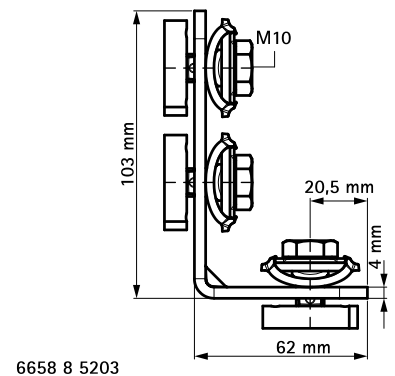
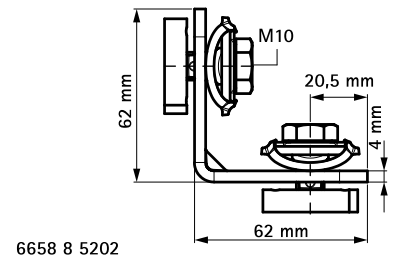
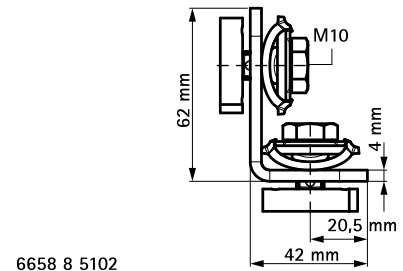

Complementary

BIS RapidStrut® Fixing Rail DS 5
(BUP1000)