

SOLOLIFT2 C-3 & D-2

COMPACT GREY WATER HANDLING STATION



WATER SOURCE



Grey Water

APPLICATION



Grey Water Handling



SCAN THE QR CODE TO LINK TO GRUNDFOS PRODUCT CENTER

The Grundfos SOLOLIFT2 C-3 & D-2 lifting stations are compact, all-in-one pumping units designed for the effective handling of grey water from bathrooms, kitchens or laundries. Designed to be installed below street level or away from existing sewerage pipework.

- **Space saving design fits small spaces** - Compact units making them suitable for installation in to small areas
- **Low installation costs** - Plumbing connections are adjustable up to 10 mm, making installation to existing or new pipework simple and inexpensive
- **Very low maintenance** - Thanks to separated motor, pump and tank the D-2 and C-3 are very easy to maintain. Most blockages can be cleared without the need to open the units.

SOLOLIFT2 C-3 - Suitable for connection to a maximum of three appliances, including hand basins, showers, bathtubs or kitchen sinks, as well as to washing machines and dishwashers, where high temperature water may enter the system

SOLOLIFT2 D-2 - Suitable for connection to a maximum of two appliances such as hand basins and showers



SOLOLIFT2 C-3

SOLOLIFT2 D-2

PUMP SIZING - SOLOLIFT2 C-3

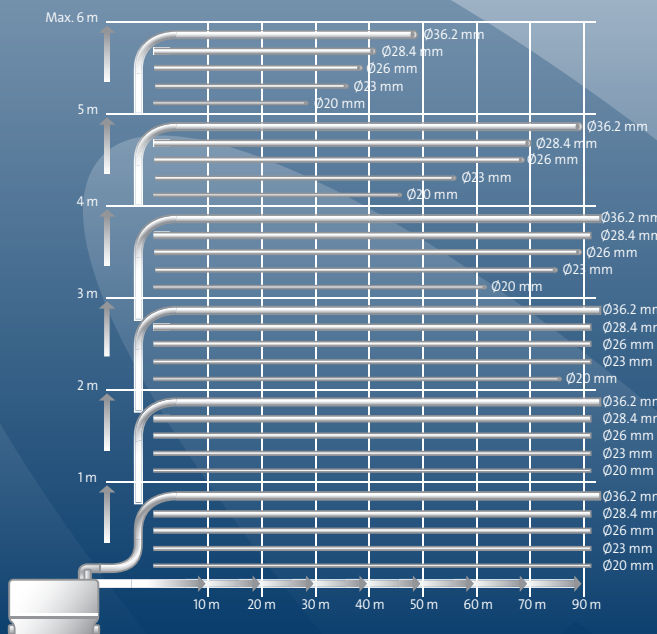

PUMP SIZING - SOLOLIFT2 D-2

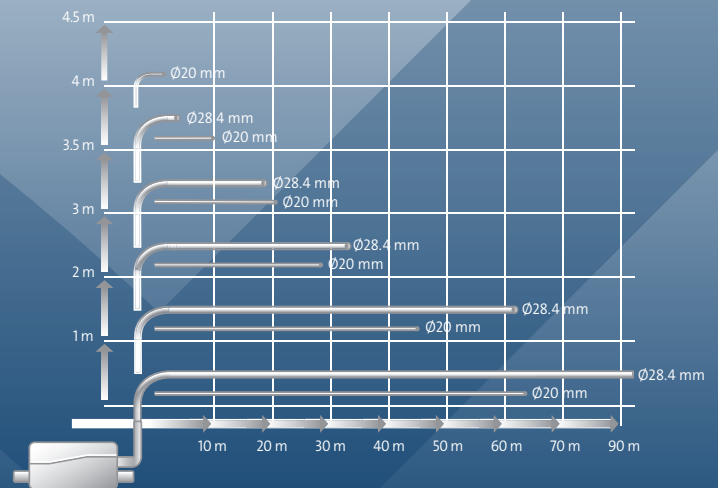

TECHNICAL DATA

INSTALLATION SCHEMATIC*

SOLOLIFT2 C-3

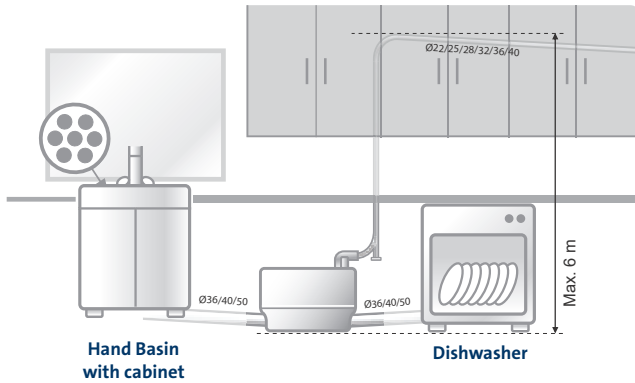

SOLOLIFT2 D-2

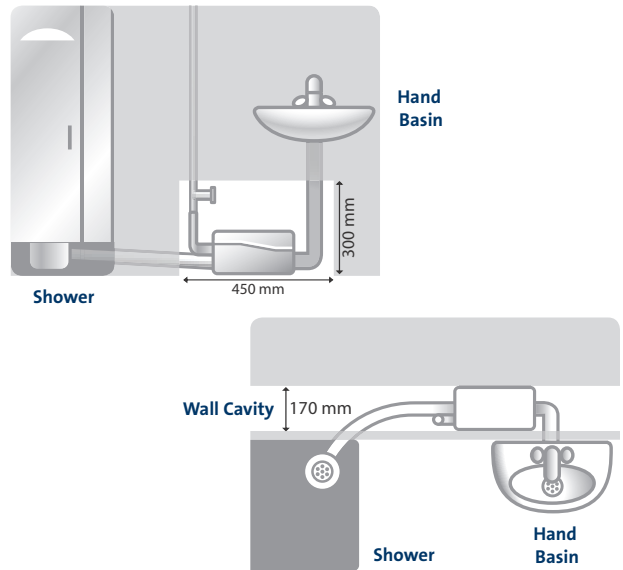

*Illustrative purposes only

OPERATING CONDITIONS

Liquid Temperature	SOLOLIFT2 C-3: 0°C to +75°C (90°C 30 mins) SOLOLIFT2 D-2: 0°C to +50°C
pH value of pumped liquid	4-10
Tank Volume	SOLOLIFT2 C-3: 5.7 litres SOLOLIFT2 D-2: 2.0 litres
Sound Pressure	Max. 70 dB

TECHNICAL DATA

Power Supply Voltage	220-240 Volt, 50 Hz
Power Supply Cable	1.2 m with plug
Enclosure Class	Requires indoor installation (IP44)
Approvals and Markings	WaterMark Approved C-Tick Compliance

PHYSICAL ATTRIBUTES

SOLOLIFT2 C-3

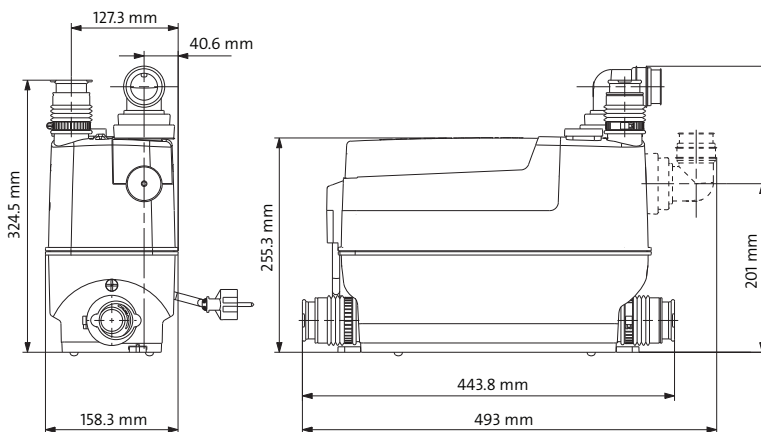

SOLOLIFT2 D-2

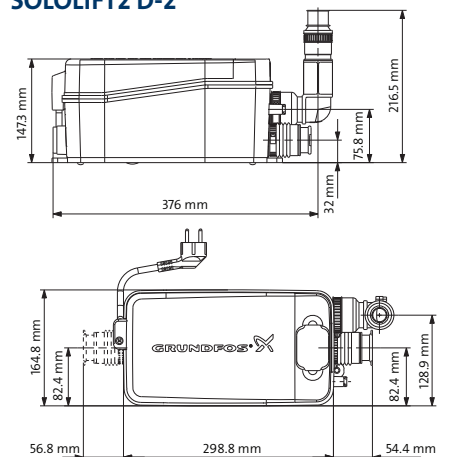

Model	Motor Power P2 (kW)	Connections						Weight (kg)
		Inlet (Toilet)	Inlet (Top)	Inlet (Right)	Inlet (Left)	Outlet (Top)	Outlet (Side)	
SOLOLIFT2 C-3	0.42	100 mm	32/36/40 mm	36/40/50 mm	36/40/50 mm	22/25/28/32/36/40 mm	22/25/28/32/36/40 mm	7
SOLOLIFT2 D-2	0.16	100 mm	-	36/40 mm	36/40 mm	-	22/32 mm	4