

MILLI EDGE MK2

WALL BATH MIXER SET 160MM

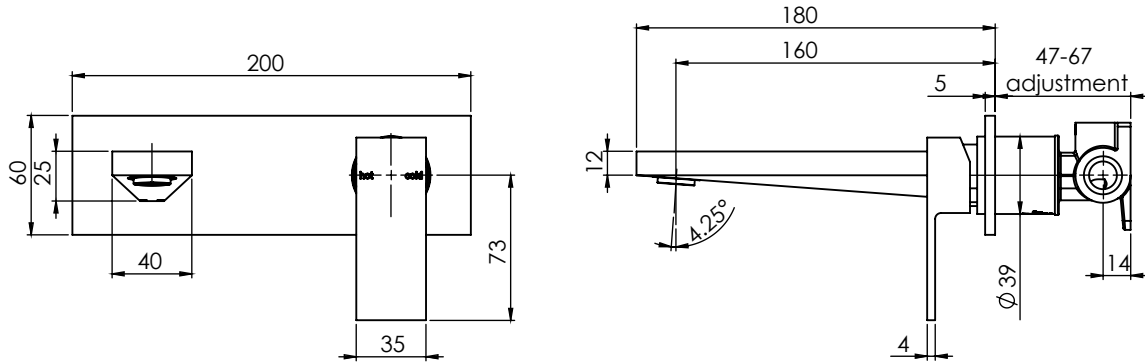

Dimensions are nominal measurements only.

SPECIFICATIONS

Recommended Use	Domestic, Hotel and Commercial
Colour Availability	Chrome
Pressure Rating	Maximum continuous operating pressure 500 kPa. Note: For best performance and longer life, we recommend 150-500 kPa.
Temperature Rating	Maximum continuous working temperature 75°C
Suitable Hot Water	Storage Tank: Yes Continuous Flow: Refer to manufacturer of continuous hot water systems Gravity Feed: No
Standards	AS/NZS 3718



To see the complete MILLI range go to www.reece.com.au/bathrooms

CLEANING RECOMMENDATIONS

We recommend the use of soapy water or approved cleaners.

This product should not be cleaned with abrasive materials.

Damage caused by any improper treatment is not covered by the product warranty- refer to Warranty Conditions.



Disclaimer: Products in this specification manual must by regulation be installed by licensed and registered trade people. The manufacturer/distributor reserves the right to vary specifications or delete models from their range without prior notification. Dimensions are nominal measurements only. Dimensions and set-outs listed are correct at time of publication however the manufacturer/distributor takes no responsibility for printing errors.

Tech Page Version 1



MILLI EDGE MK2 WALL BATH MIXER SET 160MM

INSTALLATION INSTRUCTIONS

Important Note

Mixer must be installed to the requirements of AS/NZS 3500 by a qualified plumber. Your mixer comes to you already factory assembled and tested. We do not recommend the dismantling of any internal part of the mixer. The mixers are factory tested and sealed so as to give the best performance.

INSTALLATION INSTRUCTIONS
WALL MIXER SET
IN0283 REV A

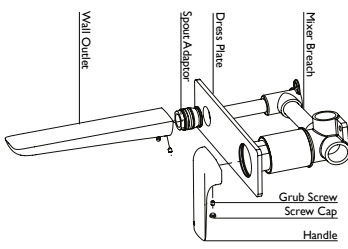
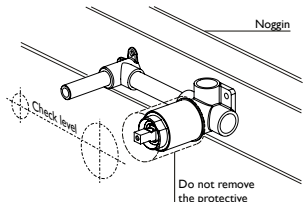
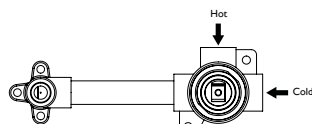
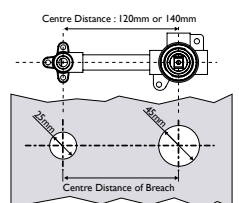
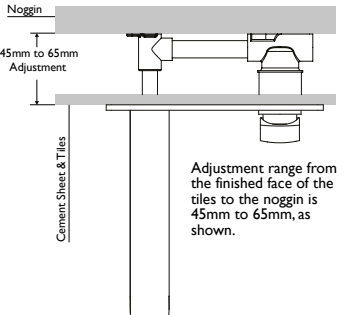
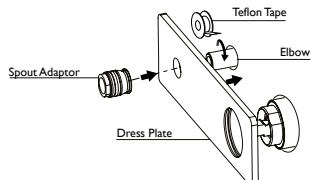
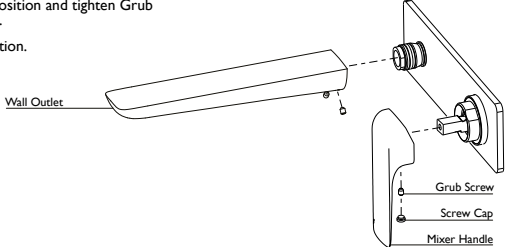
1

Screw the Mixer Breach onto Noggin.
Ensure that the Outlet and Mixer Body centres are level.

2

Connect hot and cold water supply, as shown.
Test and check for leaks.

3

Check centre distance of the breach assembly for 120mm or 140mm size.
Mark centre line according to measured result.
Create a 25mm hole and a 45mm hole on the cement sheet and tiles, as shown.

4

Remove the protective cover from the mixer.
Apply Teflon tape to Elbow Thread.
Gently push the dress plate into position.
Screw Spout Adaptor to Elbow Thread with a spanner or Allen Key.

5

Push Wall Outlet to the spout adaptor and fasten Grub Screws to secure Wall Outlet.
Fit Mixer Handle into position and tighten Grub Screw to secure handle.
Fit Screw Cap into position.

recommended working pressure
150-500kPa
maximum hot water temperature
75 degrees

NOTE:

- If the pressure exceeds or is likely to exceed 550kPa, an approved pressure limiting device must be installed.
- Flush out all pipe work prior to installation.
- If the water temperature exceeds 75°C, an approved tempering valve must be fitted.
- Installation should comply with Australian standard AS3500.1 or relevant local authority requirements.

Showers may not be suitable for use within:

- Gravity-fed water systems
- Some instantaneous hot water systems; or

• Pressure supply less than 150kPa.
NOTE: The 500kPa maximum water supply pressure does not apply to fire service outlets.

Failure to comply with the above may void all warranties.

WARRANTY:
Please refer to the full warranty statement enclosed with the product before installing.

MAINTENANCE AND CARE:

- Products should be cleaned with mild liquid detergent or soap and water.
- Do not use cream cleaners or citrus based cleaning products, as they are abrasive.
- Use of unsuitable cleaning agents may damage the surface. Any damage caused in this way will not be covered by warranty.

DISCLAIMER:
While we aim to ensure the specifications shown are correct at the time of printing, we reserve the right to make modifications without prior notice. Always use the physical product measurements for mark-ups and roughing-in as the line drawing shown may differ from the actual product over time.

*All measurements are shown in millimeters.

Plumbers, please ensure a copy of the installation instructions is left with the end user for future reference

