

ebm-papst Alpha Pump

The efficient replacement evaporator pump

The ebm-papst Alpha pump: the reliable, efficient replacement of your old evap pump

It is that time of year again – the days are getting longer and the heat is slowly returning to the Australian South. This is a friendly reminder to stock up on your ebm-papst Alpha Pump. The Alpha Pump is the efficient and reliable replacement of existing evaporator pumps.

Benefits at a glance

- Reliable external rotor motor
- Efficient – up to 20% less energy use
- Performance improved by 20%*
- Easy replacement of most evap pumps on the market
- Exclusive proven design for harsh Australian conditions
- Environmentally friendly: 30% recycled plastic
- Low draft - requires minimum of only 57mm water depth
- 2 year warranty

*measured at 1500-2000mm head

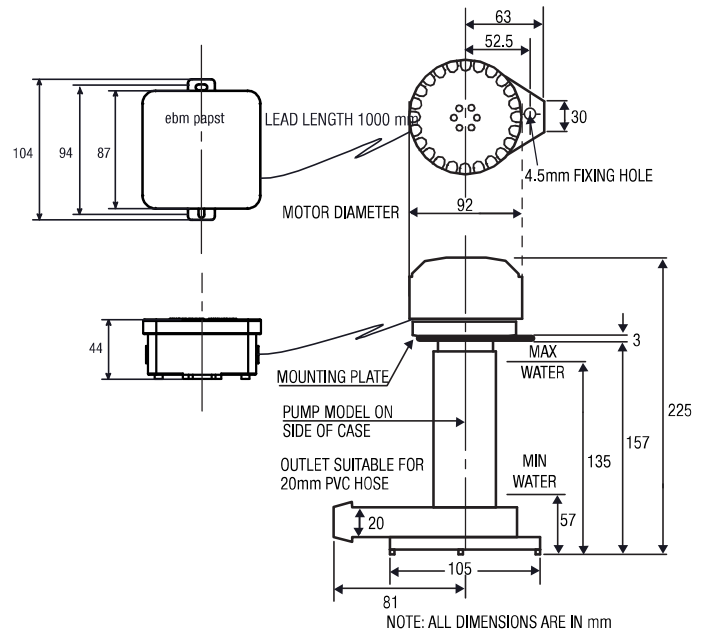

Technical Data**

Model	Power supply	Watts	Flow l/min at 1m head	Flow l/min at 2m head	Motor	Bearings
ebm Alpha	240V/50Hz	50	32	25	External rotor motor	Ball

** Typical data which can vary by location and filter material.

Attention: Warranty will be voided if pump is operated outside the permissible water level.
Pump is to be used within evaporator cooler unit without motor being exposed to direct contact with water.

ebm-papst Victoria
10 Oxford Road
Laverton North VIC 3026
Phone (03) 9360 6400
sales@ebmpapst.com.au

ebm-papst New South Wales
Unit 13, 19 Aero Road
Ingleburn NSW 2565
Phone (02) 9827 6400
sales@ebmpapst.com.au

ebm-papst New Zealand
Unit H, 61 Hugo Johnston Drive
Penrose Auckland 1061
Phone +64 (9) 525 0245
all_nzsales@au.ebmpapst.com

ebmpapst

The engineer's choice