

CENTURION AMBULANT PAN

2.06

TOILETS

#PCAM / CENTURION AMBULANT PAN

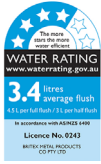

WELS REG#
P Trap: L06723
S Trap: L06722



Scan QR code
to view online



N.B: All Britex disabled and ambulant toilet pans are supplied with our Vandal Resistant Closed Front Toilet Seat (black colour unless otherwise specified) to comply with AS1428 Disability Code.

features and benefits

- WELS and WaterMark certified
- AS1428 compliant, ambulant toilets
- Available with S or P trap
- Concealed fixings
- Unique blockage resistant trap
- Safety radius front edges
- Left and right access panels
- Free of ligature points
- Option for permanently sealed access panels (maximum Suits detention facilities and public amenities)

about

The *BRITEX Centurion Ambulant Toilet Pan* is fully shrouded and manufactured from heavy gauge grade 304 satin S.S. making it easy to clean and providing optimal strength. It is designed to conform to Australian Standard, Design for Access and Mobility - AS1428, with respect to ambulant users. Incorporating radius edges for added safety, a pressed internal bowl and unique trap design, the Centurion Ambulant pan is extremely water efficient (4.5/3 litre) and much less susceptible to costly blockages in public amenities. Access panels come standard on both sides of the pan for easy installation and a toilet seat can be fitted if required. WaterMark and WELS certified as required by plumbing regulations and government legislation.

sample spec. text

BRITEX S.S. Centurion Ambulant Toilet Pan - 4 WELS rating and WaterMark certified. S/P Trap, 14mm safety radius front edge, fully shrouded to rear wall and 2 x access panels. Supplied complete with toilet seat; code XXXX. AS 1428 compliant - Product Code PCAMX*

*RED TEXT may denote a **variable** where one option only is to be selected, a **nominal dimension** that needs to be specified, or an **optional feature** that can be removed if not required. Please refer to the back of this page for additional specification details and options.

VISIT BRITEX.COM.AU TO DOWNLOAD BIM FILES, CAD DRAWINGS AND THE MOST CURRENT PRODUCT LITERATURE.



MELBOURNE
Britex Place, Mirra Crt
Bundoora VIC 3083
t (03) 9466 9000
f (03) 9466 9011

SYDNEY
16 Northumberland Drv
Taren Point NSW 2229
t (02) 9531 2100
f (02) 9531 2800

PERTH
Unit 1/8 Principal Link
Malaga WA 6090
t (08) 9249 5464
f (08) 9248 6893

BRISBANE
19 Manilla St
East Brisbane QLD 4169
t (07) 3363 2400
f (07) 3363 2444

ADELAIDE
The Britex Group
SA State Office
t 1300 764 744
f 1300 784 306

britex.com.au | info@britex.com.au | A.B.N 83 004 309 737

CENTURION AMBULANT PAN

PRODUCT CODE

PCAMS S Trap Model

PCAMP P Trap Model

MAXIMUM SECURITY MODEL AVAILABLE

Add '-MS' to the end of the above product codes to specify a maximum security, rear access only model supplied with permanently sealed side access panels.

Suggested Toilet Seat Options:

(see Toilet Seats: 2.18 for complete range of options)



SVRC-B
Vandal Resistant
Closed Front
Toilet Seat - BLACK



SVRC-W
Vandal Resistant
Closed Front
Toilet Seat - WHITE



SVRC-N
Vandal Resistant
Closed Front
Toilet Seat - NAVY

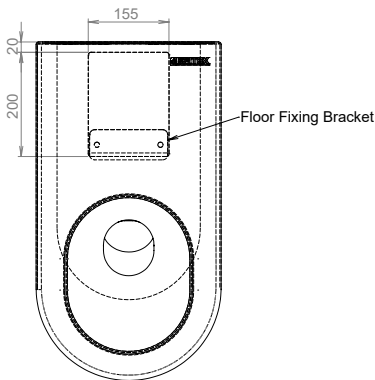

MODEL PCAMS / PCAMP Plan

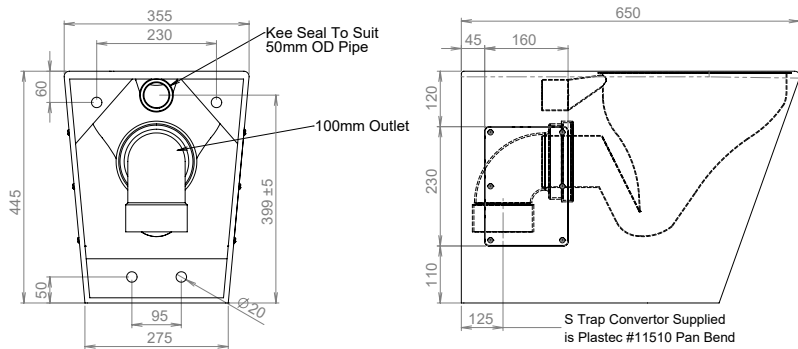

MODEL PCAMS Side and Rear Elevation

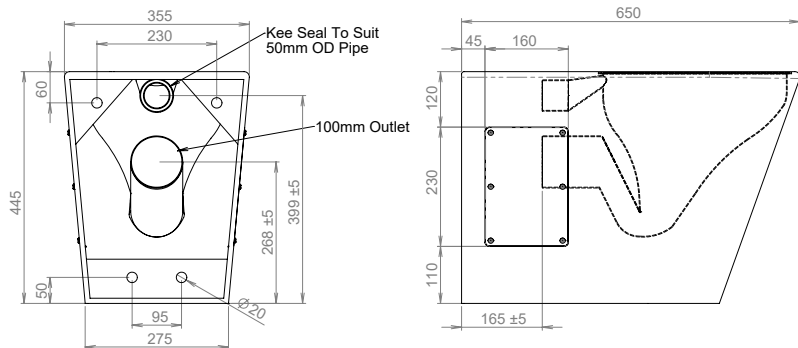

MODEL PCAMP Side and Rear Elevation

When specifying this product please include:

- Product Name and Code
- Product Dimensions

specifying guide

options

- Toilet Seat see p 2.18
- Backrest - as required by AS1428 see p 2.19
- S or P trap configurations
- Top entry to suit wall mount cistern
- Britex Cistern - see Flushing Section:3
- Permanently sealed access panels for maximum security projects
- Custom material thickness - consult BRITEX

VISIT BRITEX.COM.AU TO DOWNLOAD BIM FILES, CAD DRAWINGS AND THE MOST CURRENT PRODUCT LITERATURE.

Last Revised 2020



Due to ongoing research and our commitment to product development, details are subject to change without notice. Details accurate at time of print. Please refer to britex.com.au for the most current product information. Allow +/- 5mm tolerance for dimensions and setouts shown in product literature.



britex.com.au | info@britex.com.au | A.B.N 83 004 309 737

Quality 150 9001