

Laufen Ino Wall / Counter Basin with Overflow 1 Taphole 450mm White

SPECIFICATIONS

Recommended Use	Domestic, Hotel & Commercial
Material	Saphirkeramic
Colour	White
Bowl Capacity	4.1 Litres
Weight	6.5kg
Fixing	Template (included) Fixing Bolts (not included) Waterproof Flexible Sealant (not included)
Taphole Configuration	1 Centre Taphole
Overflow Configuration	Overflow
Waste Size	Suits 32x40mm Overflow Waste
Plug & Waste	Sold Separately
Tapware	Sold Separately

WARRANTY

Warranty - Domestic Use	15 Years
Spare Parts & Labour	12 Months

Please refer to Warranty Page for full Terms and Conditions

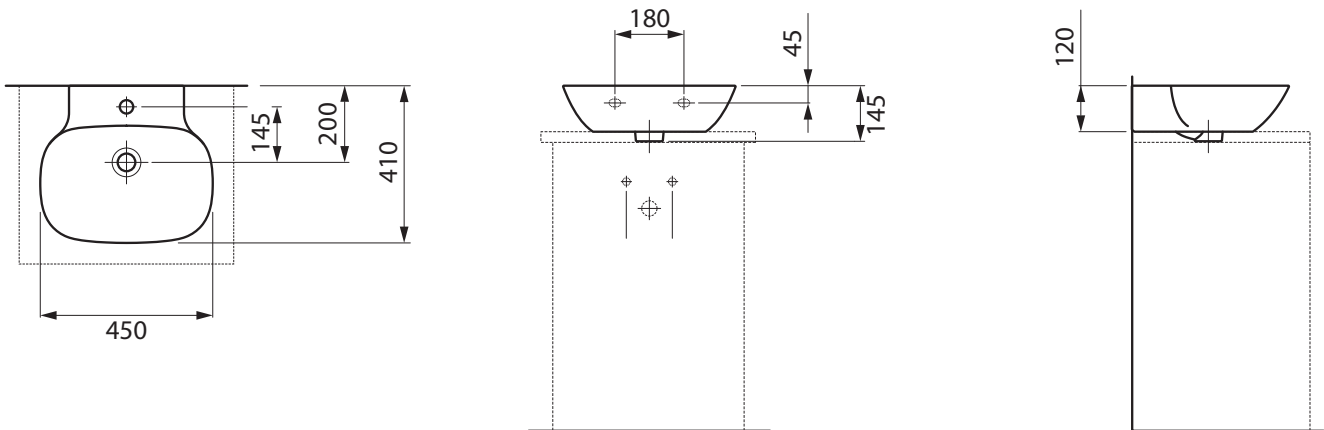

Dimensions are nominal measurements only.

Disclaimer: Products in this specification manual must by regulation be installed by licensed and registered trade people. The manufacturer/distributor reserves the right to vary specifications or delete models from their range without prior notification. Dimensions are nominal measurements only. Dimensions and set-outs listed are correct at time of publication however the manufacturer/distributor takes no responsibility for printing errors.

Published 16/01/2018

To see the complete Laufen range go to
www.reece.com.au/bathrooms

