

# MIZU

## BLOC BATH SET 250

### BATH OUTLET

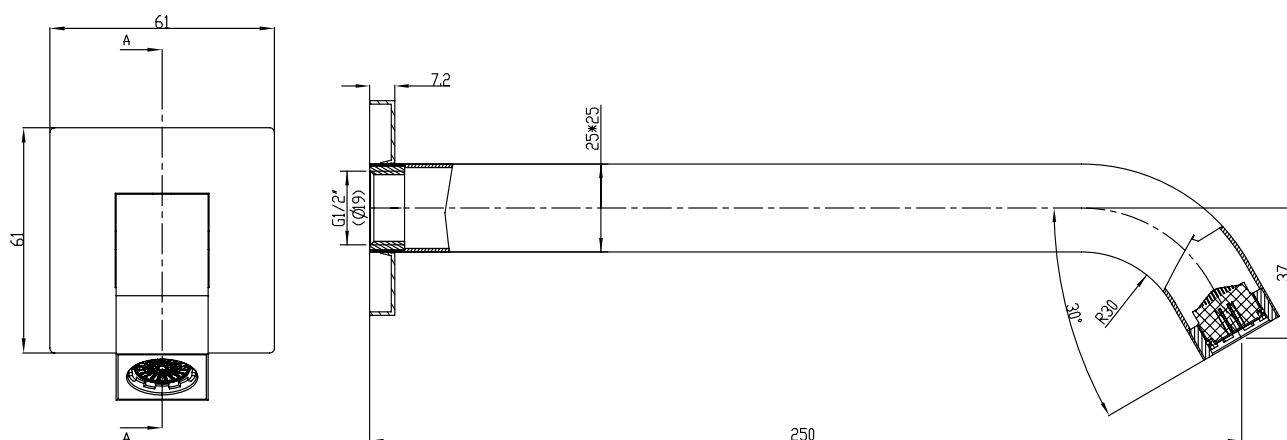

Dimensions are nominal measurements only.

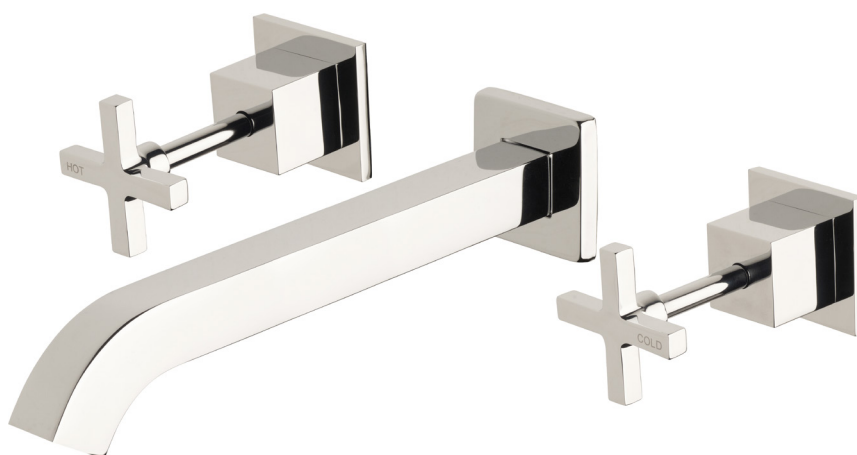

#### BATH OUTLET SPECIFICATIONS

<b>Recommended use</b>	Domestic, hotel and commercial
<b>Colour availability</b>	Chrome
<b>Standards</b>	AS/NZS 3718

To see the complete Mizu range go to  
[www.reece.com.au/bathrooms](http://www.reece.com.au/bathrooms)

**W**  
 AS/NZS 3718  
 WMKA 25013

**Disclaimer:** Products in this specification manual must by regulation be installed by licensed and registered trade people. The manufacturer/distributor reserves the right to vary specifications or delete models from their range without prior notification. Dimensions are nominal measurements only. Dimensions and set-outs listed are correct at time of publication however the manufacturer/distributor takes no responsibility for printing errors.

Tech Page Version 1

m i z u

**reece**

# MIZU

## BLOC WALL BATH SET 250

### WALL TOP ASSEMBLIES

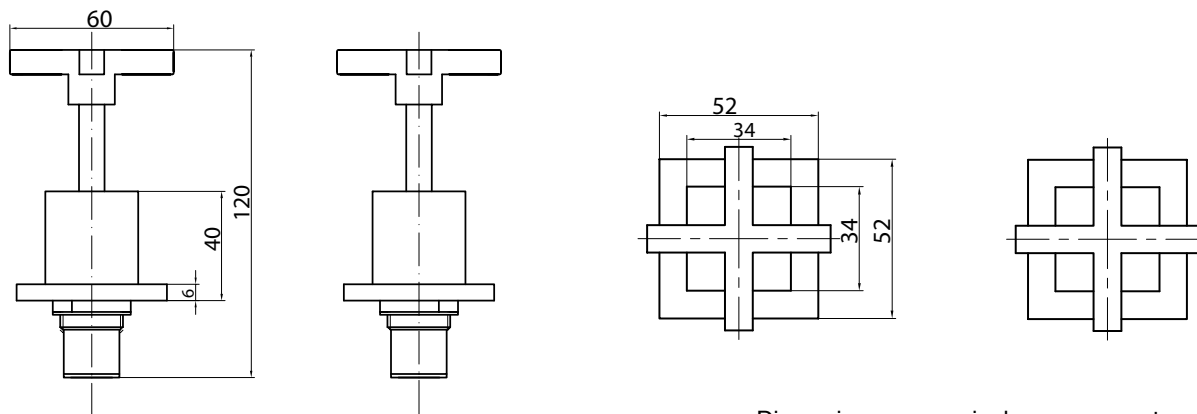

Dimensions are nominal measurements only.

### SPECIFICATIONS

<b>Recommended use</b>	Domestic, hotel and commercial.
<b>Colour</b>	Chrome
<b>Pressure Rating</b>	Maximum continuous operating pressure 1000kPa. For best performance and longer life we recommend 150-500kPa. Hot and cold water inlet pressure should be equal.
<b>Temperature Rating</b>	Maximum continuous working temperature 80°
<b>Suitable Hot Water Units</b>	Storage Tank: Yes Continuous Flow: Yes Gravity Feed: Yes



To see the complete Mizu range go to [www.reece.com.au/bathrooms](http://www.reece.com.au/bathrooms)

### CLEANING RECOMMENDATIONS

We recommend the use of soapy water or approved cleaners.

This product should not be cleaned with abrasive materials.

Damage caused by any improper treatment is not covered by the product warranty- refer to Warranty Conditions.

# MIZU

## BLOC BATH SET 250

### WALL TOP ASSEMBLIES INSTALLATION INSTRUCTIONS

1. Check the breach is between 0-20mm from the finished wall.
2. Check seats in recess tap bodies are in good condition and free of foreign materials. Re-seat if required.
3. Separate locknut (9) and fibre washer (10) from cartridge.
4. Grip the cartridge on the hexagonal flats and install cartridge fully into breach until it comes to a firm stop. Do not tighten cartridge into position by rotating spindle.
5. Turn spindle to off position and turn on water at mains. Check that cartridge has fully seated. If dripping occurs then gentle tighten cartridge further until dripping stops.
6. Firmly tighten cartridge locknut (9) and fibre washer (10) into position.
7. Place dress ring (8) & seal into position by screwing wall flange (5) onto lock nut (9) until it is tight against the wall.
8. Turn cartridge spindles to the fully OFF position and assemble handle.

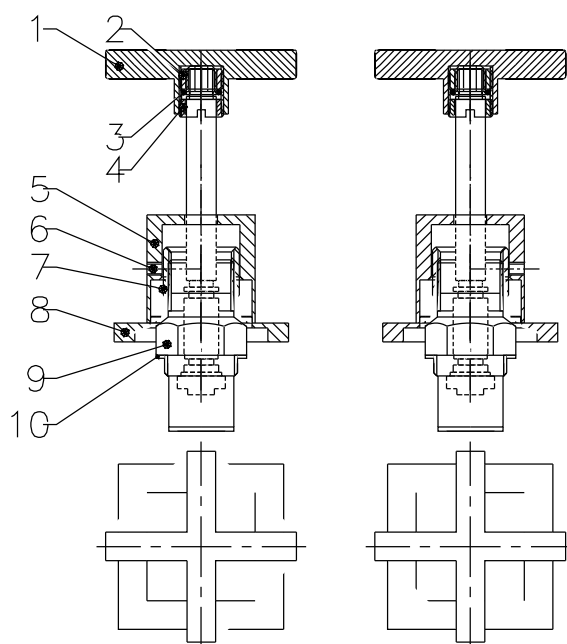

#### Exploded View

#### Item Description

1	Handle
2	Lock Nut
3	Circlip
4	Lock Nut
5	Wall Flange
6	Bolt
7	Nut
8	Handle
9	Lock Nut
10	Fibre Washer

# MIZU

## BLOC BATH SET 250



### REECE PRODUCT QUALITY GUARANTEE

You have purchased a quality product from Reece Pty Ltd ABN 84 004 097 090 ("Reece"). This product is covered by a 7 year replacement product warranty and a 12 month warranty over spare parts and labour.

#### 7 YEAR WARRANTY – DOMESTIC USE

This warranty covers faults in the product construction, material and assembly. Products which are within 7 years from the date of purchase, found upon inspection by an authorised Reece representative, to be defective in construction, material or assembly, will be repaired or exchanged with an equivalent product free of charge. Replaced items become Reece's property. This warranty also covers any spare parts included under "Manufacturer's Provisions" below.

All replacement products will be available for collection without charge to the customer at the nearest Reece branch to the customer's location, or elsewhere as agreed between the customer and Reece.

#### Manufacturer's Provisions

The following spare parts are covered by a 7 year warranty:

- Mixer Cartridge

#### Labour and Spare Parts

The labour for the replacement of products and spare parts to which this warranty applies will be supplied by Reece or relevant supplier using licensed plumbers engaged by Reece or relevant supplier within 1 year from the date of purchase.

Spare parts other than those listed in the Manufacturer's Provisions above, which are within 1 year from the date of purchase found upon inspection by an authorised Reece representative to be defective in construction, material or assembly, will be replaced free of charge.

#### Warranty Conditions

This warranty will apply only under all of the following conditions:

- The item has been installed by a licensed plumber
- The item has been installed for and subjected to domestic residential use only
- Failure is due to a fault in the manufacture of the product
- Proof of purchase (including the date of purchase) is provided
- The installation of the product is in accordance with the instructions provided

This warranty does not cover products purchased as an ex-display without being fully checked and tested for sale by the manufacturer.

This warranty does not include faults caused by:

- Unsuitable or improper use
- Incorrect installation or installation not in accordance with the instructions provided
- Installation or part installation by the purchaser or any person other than a LICENSED PLUMBER
- Normal wear and tear
- Inadequate or complete lack of maintenance
- Chemical, electrochemical or electrical influences
- Harsh detergents or abrasive cleaners used on product finishes

#### 1 YEAR WARRANTY – COMMERCIAL USE

'Commercial' use is all use other than for normal domestic residential purposes, including use in non-business places as in public buildings, schools, sports centres and in establishments that contain private bathrooms with high frequency of use by many individuals, such as hotels, motels, retirement villages and hospitals.

The Commercial warranty covers this product against manufacturing faults in the construction, material and assembly of both the finished products and any spare parts for a period of 1 year from the date of purchase. Products and spare parts which are found upon inspection by an authorised Reece representative to be defective in construction, material or assembly will be repaired or exchanged free of charge. Replaced items become Reece's property. The labour for the replacement of products and spare parts to which this warranty applies will be supplied by Reece or relevant supplier using licensed plumbers engaged by Reece or relevant supplier. The Warranty Conditions and exclusions which apply to the domestic use warranty also apply to this commercial warranty.

#### EXCLUSIONS

To the fullest extent permitted by law, Reece excludes all liability for damage or injury to any person, damage to any property, and any indirect consequential or other loss or damage.

#### CLAIM PROCEDURE

For all warranty queries customers are to contact the branch where the product was purchased. These details can be found on your purchase invoice.

Our goods come with guarantees that cannot be excluded under the Australian Consumer Law. You are entitled to a replacement or refund for a major failure and for compensation for any other reasonably foreseeable loss or damage. You are also entitled to have the goods repaired or replaced if the goods fail to be of acceptable quality and the failure does not amount to a major failure.