



Compressor
Voltage Code : FZ

AE4460Z-FZ1C

High Temp. Commercial (HP)

220 - 240V 1~ 50 Hz

R452A / R404A / R448A / R449A

AE4460Z-FZ1C

Conditions	Frequency	Nominal Cooling Capacity		Sound Power ISO3745 / ISO 3743-1
		Watts	BTU/h	
EN12900 / R452A	50 Hz	1366	4660	61 dBA
EN12900 / R404A	50 Hz	1363	4648	61 dBA
EN12900 / R448A	50 Hz	1368	4664	61 dBA
EN12900 / R449A	50 Hz	1368	4664	61 dBA

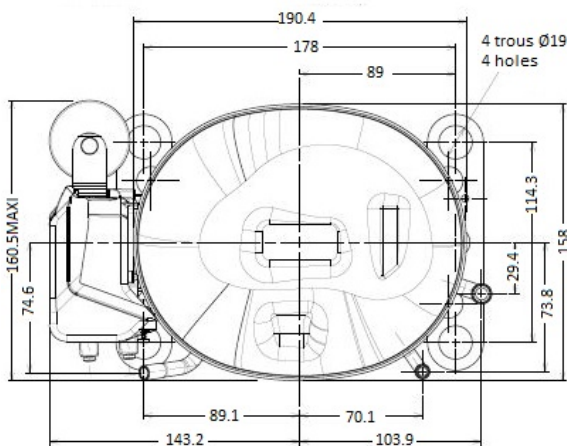
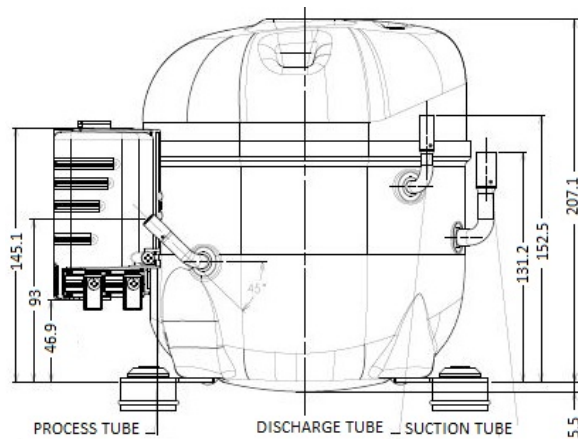

* EN12900 : T°Cond. 50.0°C / T°Evap. 5.0°C / T°Return gas temp.. 20.0°C
T°Subcooling. 0.0K

Certificates :



Displacement (cc)	10.33
Net Weight (Kg)	11.5
Oil Quantity (cc)	380.0
Oil Type	Polyolester
Expansion Device	Capillary_Tube/Expansion_Valve
Cooling	Fan
Main Winding (Ohm)	3.49
Start Winding (Ohm)	19.12
Current	
RLA (A)	4.3
LRA (A)	19.0
Electrical Equipment	CSIR
Overload	T8107
Time Check	6.5s - 16s / 12.50 A
Open Temp	135° C
Close Temp	61° C
Start Capacitor	64 µF / 330 V
Current Relay	RP54**
Pick Up	10.50A
Drop Out	8.9A
Refrigerating connection for OD	
Suction Tube	9.5 (3/8")
Discharge Tube	6.35 (1/4")
Process Tube	6.35 (1/4")

Note : Tecumseh reserves the right to change information contained in this document without notification.



Tecumseh

AE4460Z-FZ1C	Tension FZ : 220 - 240V 1~ 50 Hz
---------------------	---

Les performances sont données dans les conditions EN12900 :	Gaz aspirés :	20.0 °C
Condition Dew	Sous refroidissement :	0.0 K
The performance data are in EN12900 conditions :	Return gas :	20.0 °C
Dew Condition	Subcooling :	0.0 K

50 Hz R452A											
											N°3117
4 T condensation	5 T évaporation	(°C)	-25	-20	-15	-10	-5	0	5	10	15
30	1 P frigorifique	(Watt)	569	716	890	1095	1335	1614	1937	2306	2727
	2 P absorbée	(W)	350	377	405	432	458	483	506	525	542
	3 I absorbée	(A)	2.83	2.94	3.04	3.13	3.21	3.28	3.34	3.39	3.44
40	1 P frigorifique	(Watt)		601	756	935	1142	1382	1658	1975	2337
	2 P absorbée	(W)		408	442	476	511	546	579	611	640
	3 I absorbée	(A)		2.95	3.11	3.25	3.39	3.51	3.63	3.73	3.82
50	1 P frigorifique	(Watt)			613	765	938	1137	1366	1630	1931
	2 P absorbée	(W)			478	521	564	608	652	695	737
	3 I absorbée	(A)			3.18	3.38	3.57	3.75	3.92	4.08	4.23
60	1 P frigorifique	(Watt)				585	723	880	1060	1268	1508
	2 P absorbée	(W)				570	621	675	729	784	838
	3 I absorbée	(A)				3.52	3.76	4.00	4.22	4.43	4.64

50 Hz R404A											
											N°3114
4 T condensation	5 T évaporation	(°C)	-25	-20	-15	-10	-5	0	5	10	15
30	1 P frigorifique	(Watt)	606	755	930	1135	1374	1651	1970	2334	2747
	2 P absorbée	(W)	371	398	426	453	479	503	524	543	557
	3 I absorbée	(A)	2.99	3.10	3.20	3.28	3.35	3.41	3.47	3.50	3.53
40	1 P frigorifique	(Watt)	499	633	787	964	1168	1403	1673	1981	2331
	2 P absorbée	(W)	400	432	466	500	534	568	600	630	657
	3 I absorbée	(A)	2.97	3.13	3.28	3.42	3.54	3.65	3.76	3.85	3.93
50	1 P frigorifique	(Watt)		505	636	784	952	1144	1363	1614	1900
	2 P absorbée	(W)		468	507	548	590	633	675	716	756
	3 I absorbée	(A)		3.17	3.37	3.56	3.74	3.90	4.06	4.20	4.33
60	1 P frigorifique	(Watt)			478	596	726	874	1041	1233	1454
	2 P absorbée	(W)			556	603	652	703	755	807	859
	3 I absorbée	(A)			3.48	3.72	3.95	4.17	4.37	4.57	4.75

1 = cooling capacity 2 = power input 3 = current 4 = condensing temperature 5 = evaporating temperature

Nota : Tecumseh se réserve le droit de modifier les informations contenues dans ce document sans préavis.

Note : Tecumseh reserves the right to change information contained in this document without notification.

© 2020 Tecumseh Products Company
All rights reserved



Tecumseh

AE4460Z-FZ1C	Tension FZ : 220 - 240V 1~ 50 Hz
---------------------	---

Les performances sont données dans les conditions EN12900 :	Gaz aspirés :	20.0 °C
Condition Dew	Sous refroidissement :	0.0 K
The performance data are in EN12900 conditions :	Return gas :	20.0 °C
Dew Condition	Subcooling :	0.0 K

50 Hz R448A (*)											
											N°3115
4 T condensation	5 T évaporation	(°C)	-25	-20	-15	-10	-5	0	5	10	15
30	1 P frigorifique	(Watt)	501	647	819	1022	1261	1541	1865	2239	2668
	2 P absorbée	(W)	326	351	377	404	430	454	476	495	509
	3 I absorbée	(A)	2.63	2.74	2.83	2.92	3.01	3.08	3.15	3.20	3.23
40	1 P frigorifique	(Watt)		546	701	881	1091	1336	1620	1947	2324
	2 P absorbée	(W)		383	414	447	481	514	546	576	603
	3 I absorbée	(A)		2.77	2.92	3.06	3.19	3.31	3.42	3.52	3.60
50	1 P frigorifique	(Watt)			577	734	915	1125	1368	1649	1972
	2 P absorbée	(W)			452	492	535	578	621	662	703
	3 I absorbée	(A)			3.01	3.20	3.39	3.56	3.73	3.89	4.03
60	1 P frigorifique	(Watt)				586	737	911	1112	1346	1616
	2 P absorbée	(W)				542	594	647	702	756	810
	3 I absorbée	(A)				3.34	3.59	3.83	4.06	4.28	4.49

50 Hz R449A (*)											
											N°3116
4 T condensation	5 T évaporation	(°C)	-25	-20	-15	-10	-5	0	5	10	15
30	1 P frigorifique	(Watt)	501	647	819	1022	1261	1541	1865	2239	2668
	2 P absorbée	(W)	326	351	377	404	430	454	476	495	509
	3 I absorbée	(A)	2.63	2.74	2.83	2.92	3.01	3.08	3.15	3.20	3.23
40	1 P frigorifique	(Watt)		546	701	881	1091	1336	1620	1947	2324
	2 P absorbée	(W)		383	414	447	481	514	546	576	603
	3 I absorbée	(A)		2.77	2.92	3.06	3.19	3.31	3.42	3.52	3.60
50	1 P frigorifique	(Watt)			577	734	915	1125	1368	1649	1972
	2 P absorbée	(W)			452	492	535	578	621	662	703
	3 I absorbée	(A)			3.01	3.20	3.39	3.56	3.73	3.89	4.03
60	1 P frigorifique	(Watt)				586	737	911	1112	1346	1616
	2 P absorbée	(W)				542	594	647	702	756	810
	3 I absorbée	(A)				3.34	3.59	3.83	4.06	4.28	4.49

1 = cooling capacity 2 = power input 3 = current 4 = condensing temperature 5 = evaporating temperature

(*) Veuillez vous référer strictement aux Recommandations d'Utilisation et Bulletins Marketing Tecumseh du fait de la température de reflux élevée pour les applications LBP.
 (*) Due to very high discharge temperature especially on LBP conditions, please strictly refer to Tecumseh Guidelines & Marketing Bulletin when using this refrigerant.

Nota : Tecumseh se réserve le droit de modifier les informations contenues dans ce document sans préavis.
Note : Tecumseh reserves the right to change information contained in this document without notification.

© 2020 Tecumseh Products Company
All rights reserved