

PLANNING MANUAL

Valid as of August 2019



NOTE:

**Please use this SuperTube Planning Manual
in conjunction with current Geberit HDPE Pipe
Installation Guide.**

Contents

1	History of development	5
1.1	Know-How Installed	5
1.2	History of Geberit HDPE Sovent	5
2	Basic information.....	6
2.1	Drainage.....	6
2.1.1	Falling velocity in stacks	6
2.1.2	Discharge unit (DU)	6
2.1.3	Connection values of sanitary appliances.....	7
2.1.4	Drainage factor K.....	8
2.1.5	Maximum waste water load of underground and collector pipes.....	9
2.1.6	Maximum admissible flow rate in stacks	9
3	Product description.....	10
3.1	Overview.....	10
3.2	Structure.....	11
3.2.1	Geberit SuperTube.....	11
3.2.2	Geberit HDPE Sovent fitting d160	12
3.3	Application range	13
3.4	Function.....	13
3.4.1	Geberit HDPE Sovent fittings.....	13
3.4.2	Geberit SuperTube d110.....	14
3.5	Technical data.....	15
3.5.1	The load bearing capacity of Geberit HDPE Sovent in comparison to conventional stack versions	15
3.6	Standards and tests	16
3.6.1	Standards.....	16
3.6.2	Tests.....	16
4	Planning.....	17
4.1	Planning rules in accordance with Geberit and DIN EN 12056-2:2001-01	17
4.1.1	Basic rules	17
4.1.2	Overview of the pipe sections and rules	17
4.1.3	Stack	19
4.1.4	Branch discharge pipes	24
4.1.5	Overview of stack offset.....	26
4.1.6	Geberit HDPE Sovent d110 or d160 stack offset up to 1 m	27
4.1.7	Geberit SuperTube d110 stack offset greater than 1 m.....	27
4.1.8	Geberit HDPE Sovent d160 stack offset greater than 1 m.....	30
4.1.9	Zones without connections.....	31
4.1.10	Transition to the collector pipe.....	33

4.2	Planning rules in accordance with AS/NZS 3500.2:2018 d110 & d160 Sovent (non SuperTube).....	35
4.2.1	Basic rules.....	35
4.2.2	Configuration of branch discharge pipes.....	36
4.2.3	Ventilation of branch discharge pipes.....	36
4.2.4	Load on a stack with Geberit HDPE Sovent fittings.....	36
4.2.5	Installing Geberit HDPE Sovent fittings in the stack.....	37
4.2.6	Installing several stacks.....	38
4.2.7	Transition to the collector pipe.....	39
4.2.8	Connections at the base of the stack.....	39
4.2.9	Vertical to horizontal transition of the stack.....	39
4.2.10	Stack offset.....	40
4.2.11	Mixed installation.....	40
4.2.12	Connection to the collector pipe.....	40
4.2.13	Collective ventilation of stacks.....	40
4.2.14	The use of air admittance valves.....	40
4.3	Dimensioning SuperTube d110, Sovent d160.....	41
4.3.1	Principles.....	41
4.3.2	Sample calculations.....	41
5	Installation.....	46
5.1	Installation rules.....	46
5.1.1	Basic rules.....	46
5.1.2	Prefabrication.....	46
5.2	Installation manual.....	47
5.2.1	Connecting Geberit HDPE Sovent fitting with pipe section.....	47

1 History of development

1.1 Know-How Installed

Ever since the company was founded in 1874, the name Geberit has stood for quality, easy installation and technical competence. This is no surprise. The application of our comprehensive knowledge enables us to recognise and benefit from improvement potentials in optimal fashion. It is on this basis that Geberit achieves innovations which optimise synergies and performance throughout the entire system. This approach results in extremely reliable, integrated systems which are rapid and easy to install and which set new benchmarks for the sanitary and plumbing industry.

1.2 History of Geberit HDPE Sovent

Geberit HDPE Sovent was developed in 1959 by Fritz Sommer, the respected director of a vocational school in Bern, Switzerland. Sommer wanted to substantially improve the performance of drainage systems so that there was no need for a separate ventilation pipe and the dimensions of the stack could be reduced.

A ten-storey hydraulic testing tower was built in Bern to prove the performance of the Geberit HDPE Sovent. In the 1960s and 1970s, the system was subjected to additional in-depth testing, not only in private but also in government test installations in New York, Tokyo, Paris and Stockholm, as the result of which it gained wide recognition due to its innovative design.

2 Basic information

2.1 Drainage

2.1.1 Falling velocity in stacks

The maximum falling velocity in stacks is attained after a height of 35 m and is approx. 13 m/s. Due to friction losses and the air resistance in the stack, the falling velocity does not exceed this value.

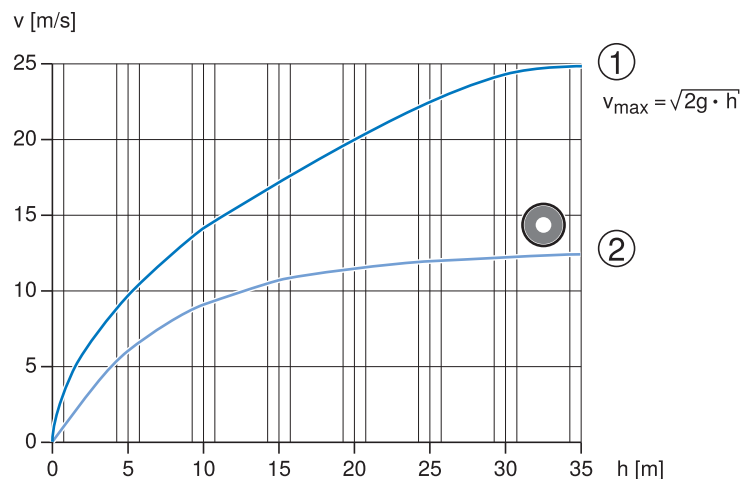

Figure 1: Theoretical falling velocity and falling velocity in stacks







- v Falling velocity [m/s]
- h Height of fall [m]
- 1 Theoretical falling velocity
- 2 Falling velocity in stacks (water film with air column)

2.1.2 Discharge unit (DU)

The DU (discharge unit) is a measure of the amount of waste water which drains from a sanitary appliance. 1 DU corresponds to a waste water volumetric flow rate of 1 l/s.

Local standards must be taken into account when determining the discharge unit. Examples of the discharge units in accordance with DIN EN 12056-2:2001-01 are stated in the following:

Table 1: Discharge units (DU) in accordance with DIN EN 12056-2:2001-01

Symbol	Sanitary appliance	DU
	Washbasin, bidet, urinal	0.5
	Shower without congestion	0.6
	Bathtub	0.8
	Kitchen sink	0.8
	WC (6 or 7 l) / WC (9 l)	2.0/2.5
	Squatting pan	2.5

2.1.3 Connection values of sanitary appliances

Every sanitary appliance has a specific connection value DU. 1 DU corresponds to a flow rate of 1 l/s.

Table 2: Connection values of sanitary appliances in DUs

Note: For any other sanitary applications such as birthing baths or mechanical discharge (Cooling Towers) etc, please contact your local Geberit Representative for advice.

Sanitary appliance	Abbreviation	Minimum diameter of the outlet and the connection pipe in DN		Fixture unit rating	DU
			Only NZ		
Autopsy table	AT	50	–	3	1.0
Bain-Marie	BM	40	–	1	0.5
Cleaner sink	B	40	32	1	0.5
Bath (with or without shower)	Bth.	40	–	4	0.8
Bath (foot)	Bath (foot)	4	–	3	0.8
Bath (Baby)	Bath (Baby)	40	–	3	0.8
Bath (Shower)	Bath (shr)	40	–	4	0.8
Bedpan steriliser	BPS	50	–	4	1.0
Bedpan cleaner	BPW	80	–	6 (F. valve) 4 (Cist)	2.0
Bedpan cleaner	BPW	100	–	6 (F. valve) b4 (Cist)	2.5 2.0
Bedpan cleaner/steriliser	BPWS	80	–	6 (F. valve) 4 (Cist)	2.5 2.0
Bedpan cleaner/steriliser	BPWS	100	–	6 (F. valve) 4 (Cist)	2.5 2.0
Bidet	Bid	40	32	1	0.5
Circular washbasin area	CWF	50	–	4	1.0
Washing machine, private	CWM	40	–	5	1.0
Washing machine, commercial	CWM	50	–	*	1.5
Dentistry unit	DU	40	–	1	0.5
Dishwasher, private	DWM	40	–	3	0.5
Dishwasher, commercial	DWM	50	–	*	1.5
Drinking fountain	DF	40	25	1	0.5
Floor drain, without sanitary appliance	FW	50	–	0 According to fixture rating	0
Floor drain, with sanitary appliance	FW	50	–	0 According to fixture rating	0
Glasswasher	GWM	40	–	3	1.0
Potato peeler	PP	50	–	3	1.0
Insert dispenser	SNDU	40	–	3	1.0
Shower, single-person	Shr	40	–	2 2 per shower head	0.6

Sanitary appliance	Abbreviation	Minimum diameter of the outlet and the connection pipe in DN		Fixture unit rating	DU
			Only NZ		
Shower, multiple-person	Shr	50	–	2 2 per showerhead	0.8
Sink, single	S	50	40	3	0.8
Sink, double	S	50	40	3	1.0
Sink, for tea	TS	50	40	1	0.5
Sink, for bar, private	BS (D)	40	–	1	0.5
Sink, for bar, commercial	BS (C)	50	–	3	1.0
Cleaner sink	CS	50	40	1	1.0
Laboratory sink	LS	50	–	1	1.0
Multi-purpose sink	PS	50	–	5	1.0
Spittoon	SH	100	–	6 (F. valve) 4 (Cist)	2.5
Trough for rinsing	Tr (A)	40	–	3	1.0
Trough for washinglaundry	Tr (L)	40	–	5	2.0
Urinal, wall-hung (including waterless)	Ur	40	32	1	0.5
Urinal, trough	Ur	50	32	1	0.8
WC	WC	80	–	6 (F. valve) 2 (Cist)	2.0
WC	WC	100	–	6 (F. valve) 4 (Cist)	2.5 2.0
Bath group in a singleroom (washbasin, bath,shower, WC)	–	–	–	6	3.5
Combination of floor drainand WC pan	PRS	80	–	6 (F. valve) 4 (Cist)	2.5
Combination of floor drainand WC pan	PRS	100	–	6 (F. valve) 4 (Cist)	2.5

*Please refer to AS/NZS 3500.2:2018 on Fixture unit ratings for continuous flows.

2.1.4 Drainage factor K

The drainage factor K is a measure of the simultaneous drainage of sanitary appliances that are connected to a stack. A factor of 0.5 for private housing or offices, for example, takes into account the fact that water is not flowing through all branch discharge pipes into the stack at the same time.

DIN EN 12056-2:2001-01 and SN 592000:2012 recommend the following drainage factors K:

Table 3: Drainage factors in accordance with DIN EN 12056-2:2001-01 and SN 592000:2012

Frequency of use and building type	K
Irregular use: e.g. residential buildings, guest houses/inns, offices	0.5
Regular use: e.g. hospitals, schools, restaurants, hotels	0.7
Frequent use: e.g. public toilets, shower rooms	1.0
Special use: e.g. laboratories	1.2

2.1.5 Maximum waste water load of underground and collector pipes

DIN EN 12056-2:2001-01 defines the maximum waste water load of underground and collector pipes depending on the filling level and slope. The following tables list the values for filling levels of 50% and 70%.

Table 4: Maximum waste water load in l/s for underground pipes or collector pipes at a filling level of 50 % in accordance with DIN EN 12056-2:2001-01

Slope J								Pipe dimension [mm] / DN
1% (1 : 100)	1.5% (1 : 66)	2% (1 : 50)	2.5% (1 : 40)	3% (1 : 33)	3.5% (1 : 28)	4% (1 : 25)	5% (1 : 20)	
2.5	3.1	3.5	4.0	4.4	4.7	5.0	5.6	110/100
4.1	5.0	5.7	6.4	7.1	7.6	8.2	9.1	125/125
7.7	9.4	10.9	12.2	13.3	14.4	15.4	17.2	160/150
14.2	17.4	20.1	22.5	24.7	26.6	28.5	31.9	200/200
26.9	32.9	38.1	42.6	46.7	50.4	53.9	60.3	250/250
48.3	59.2	68.4	76.6	83.9	90.7	96.6	108.4	315/300

Table 5: Maximum waste water load in l/s for underground pipes or collector pipes at a filling level of 70 % in accordance with DIN EN 12056-2:2001-01

Slope J								Pipe dimension [mm] / DN
1% (1 : 100)	1.5% (1 : 66)	2% (1 : 50)	2.5% (1 : 40)	3% (1 : 33)	3.5% (1 : 28)	4% (1 : 25)	5% (1 : 20)	
4.2	5.1	5.9	6.7	7.3	7.9	8.4	9.4	110/100
6.8	8.3	9.6	10.8	11.8	12.8	13.7	15.3	125/125
12.8	15.7	18.2	20.3	22.3	24.1	25.8	28.8	160/150
23.7	29.1	33.6	37.6	41.2	44.5	47.6	53.3	200/200
44.9	55.0	63.6	71.1	77.9	84.2	90.0	100.7	250/250
80.6	98.8	114.2	127.7	140.0	151.2	161.7	180.8	315/300

Note: 'J' refers to slope or grade of horizontal collector pipe.

2.1.6 Maximum admissible flow rate in stacks

The dimensions of the single-branch discharge pipes, the collector branch pipes, the underground pipes or collector pipes are selected as for conventional drainage, in accordance with the applicable country-specific standards and regulations.

The maximum admissible flow rate Q_{\max} in the stack is used as the relevant key figure for dimensioning stacks. This figure is calculated according to the following formula:

$$Q_{\max} = K \cdot \sqrt{\sum DU}$$

Q_{\max} Maximum admissible flow rate

K Country-specific drainage factor (standard residential and office building construction = 0.5)

$\sum DU$ Sum of discharge units DU

Note: Whilst most buildings fall under K factor = 0.5. For other K value factors please refer table 7 page 19

3 Product description

3.1 Overview

Geberit HDPE Sovent is a flow-optimised inlet fitting made of high-density polyethylene, which enables an economical and space-saving configuration of stacks in tall buildings.

The special design of the fitting and patented Geberit SuperTube technology produces a continuous column of air in the stack. The discharge rate of the stack increases as a result of the continuous column of air, meaning that there is no longer any need to install a ventilation pipe running in parallel and the stack dimensions can be smaller in many applications.

i A continuous column of air facilitates pressure compensation and increases the discharge rate.

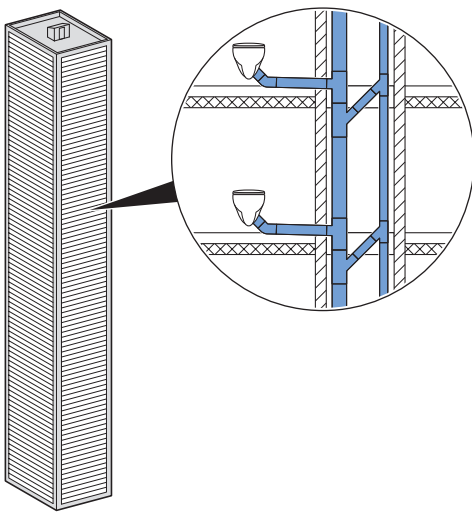

Figure 2: Conventional drainage of high-rise buildings with an additional ventilation pipe (secondary ventilation)

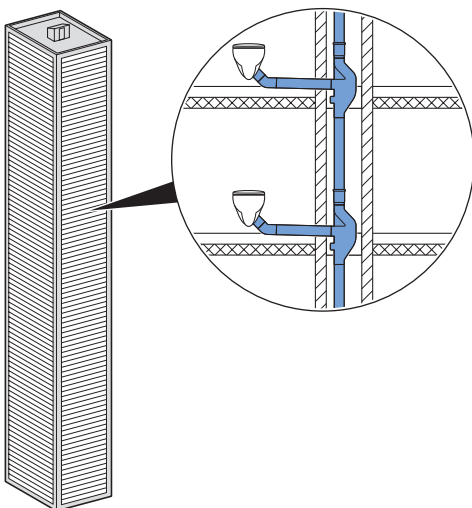

Figure 3: Drainage of high-rise buildings with Geberit HDPE Sovent

The Geberit HDPE Sovent fittings are available in the dimensions of d110 and d160.

The Geberit HDPE Sovent fitting d110 is equipped with the Geberit SuperTube technology. For changes in pipe direction in the dimension d110, the bends Geberit BottomTurn bend and Geberit BackFlip bend are additionally available, which are also equipped with the Geberit SuperTube technology. The fitting d110, in combination with the two bends, forms the Geberit SuperTube system.

3.2 Structure

3.2.1 Geberit SuperTube

Geberit SuperTube comprises:

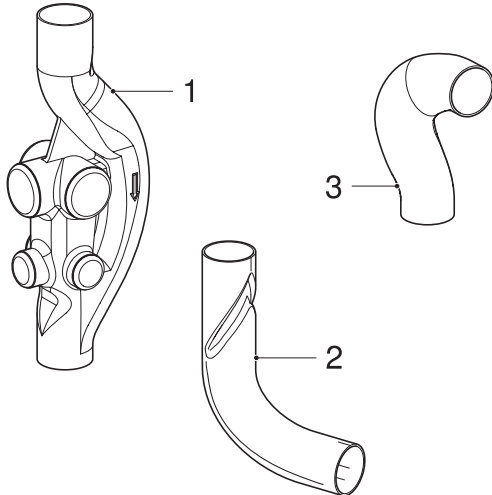

Figure 4: Structure of Geberit SuperTube

- 1 Geberit HDPE Sovent fitting d110, art. no. 367.614.16.1
- 2 Geberit HDPE BottomTurn bend d110, art. no. 367.615.16.1
- 3 Geberit HDPE BackFlip bend d110, art. no. 367.616.16.1

Geberit SuperTube is an optimised flow guidance system developed by Geberit, which ensures a continuous column of air in the stack and significantly increases the discharge rate of the fittings.

Geberit HDPE Sovent fitting d110

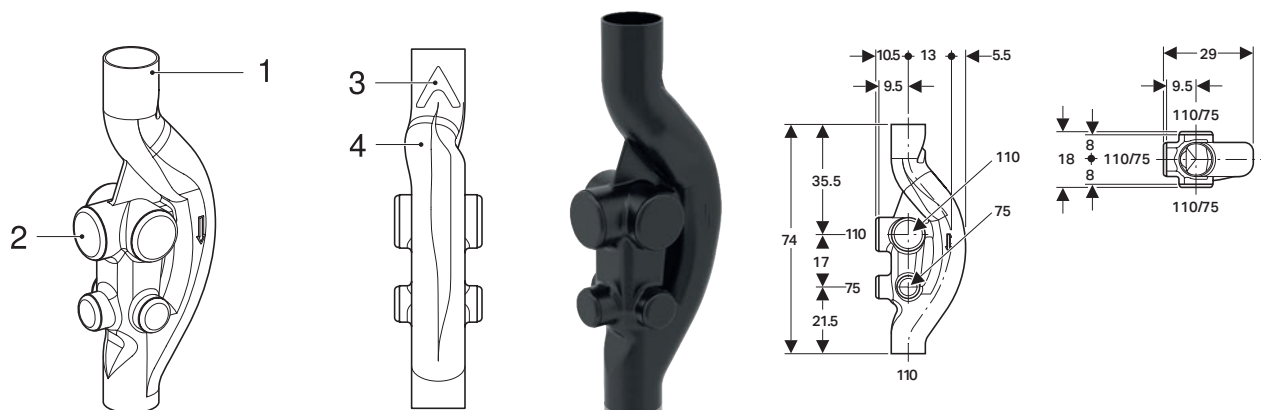

Figure 5: Structure of the Geberit HDPE Sovent fitting d110

- 1 Stack connection
- 2 Branch pipe connection, 6-way, sealed at the factory
- 3 Flow divider
- 4 Swirl zone

Geberit HDPE BottomTurn Bend d110

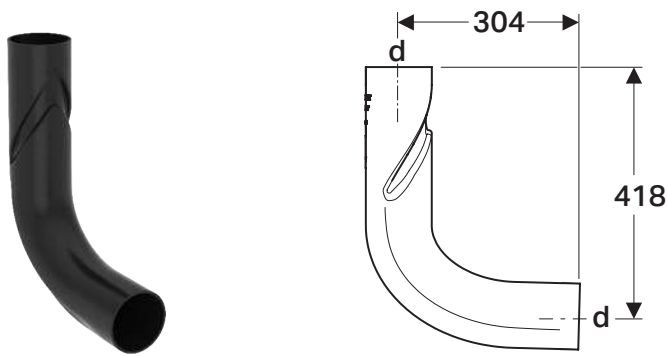

Figure 6: Structure of the Geberit HDPE BottomTurn bend d110

- 1 Guide channel
- 2 Flow divider

Geberit HDPE BackFlip Bend d110

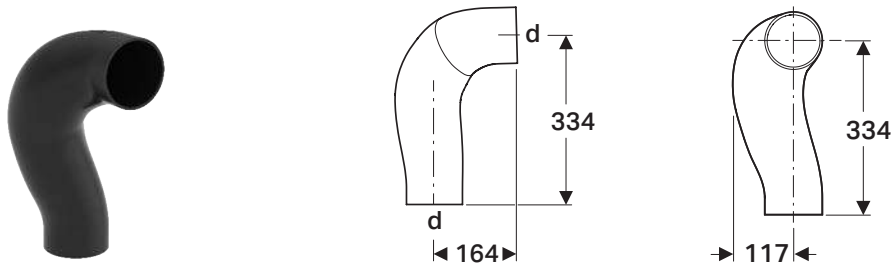

Figure 7: Structure of the Geberit HDPE BackFlip bend d110

- 1 Swirl zone

3.2.2 Geberit HDPE Sovent fitting d160

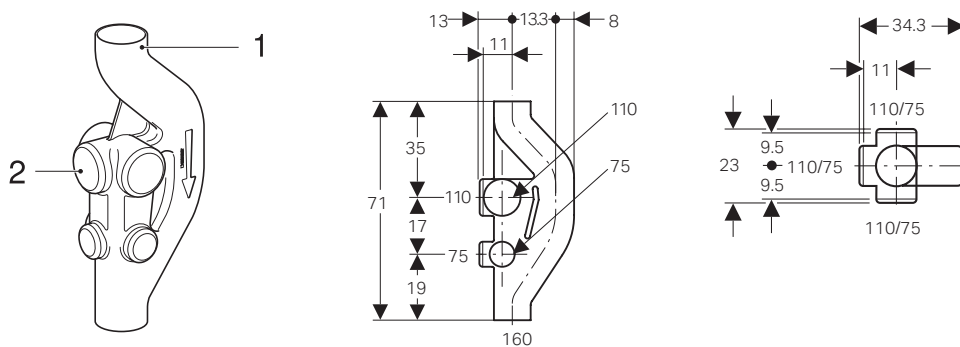

Figure 8: Structure of the Geberit HDPE Sovent fitting d160, art. no 369.001.16.1

- 1 Stack connection
- 2 Branch pipe connection, 6-way, sealed at the factory

3.3 Application range

Geberit HDPE Sovent is used for an economical and space-saving configuration of stacks in buildings with more than 5 floors (high-rise buildings).

Geberit HDPE BottomTurn bend and Geberit HDPE BackFlip bend can be used only in conjunction with Geberit HDPE Sovent fitting d110 and the drainage system Geberit HDPE.

3.4 Function

3.4.1 Geberit HDPE Sovent fittings

Hydraulic pressure compensation in a stack system is an extremely complex matter. Each stack concept is characterised by individual properties. The capacity of the stack and ventilation system is dependent on the flow capacity of the appliances, their simultaneous drainage pattern, the branch fitting inlet configuration and the drainage concept of the building. Overpressure and negative pressure in a drainage system must be limited in order to ensure the water seal in the trap.

Very high negative pressure values can arise in conventional main vent stacks. The negative pressure arises due to unfavourable flow behaviour between the stack and the branch discharge pipe. This unfavourable flow behaviour leads to a hydraulic blockage in the stack that prevents the air from circulating.

The Geberit HDPE Sovent fittings prevent a hydraulic blockage from forming in the stack. Because of the fact that the stack flow is guided around the point of connection, the incoming waste water has time to switch to the vertical direction so that it flows in a parallel direction when it meets the waste water in the stack flow. This minimises the collision turbulences of the two waste water flows and therefore reduces the pressure fluctuations in the system. Guiding the stack flow around the point of connection also causes the flow velocity to decrease which limits the kinetic pressure. In addition, the partition in the Geberit HDPE Sovent fittings prevents foam, dirt particles or splash water from getting into the branch discharge pipe.

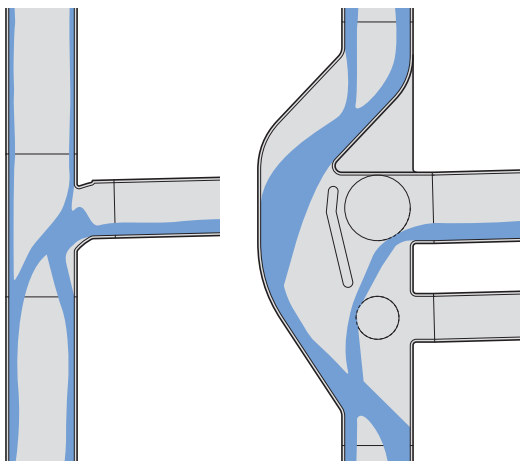

Figure 9: How the Geberit HDPE Sovent fittings function in comparison to conventional main vent stacks

3.4.2 Geberit SuperTube d110

Geberit HDPE Sovent Fittings and bends with Geberit SuperTube technology also stand out due to their patented, flow-optimised design.

The flow-optimised design in the Geberit HDPE Sovent fitting d110 is comprised of a flow divider and a swirl zone. The flow divider adjusts the flow of the water and supports functional stability in the system. The swirl zone creates a rotating movement that allows the water to flow along the pipe wall, which produces a continuous column of air. This effect increases the discharge rate of the fitting by 37.9% (from 8.7 l/s to 12 l/s).

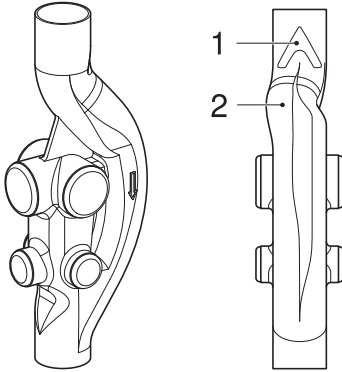

Figure 10: Geberit SuperTube technology components on the Geberit HDPE Sovent fitting d110

- 1 Flow divider
- 2 Swirl zone

3.5 Technical data

3.5.1 The load bearing capacity of Geberit HDPE Sovent in comparison to conventional stack versions

Stacks with Geberit HDPE Sovent have a higher load bearing capacity than conventional stacks with main or secondary ventilation with the same dimensions. The following table shows the maximum load of Geberit HDPE Sovent in DU compared to conventional stack versions.

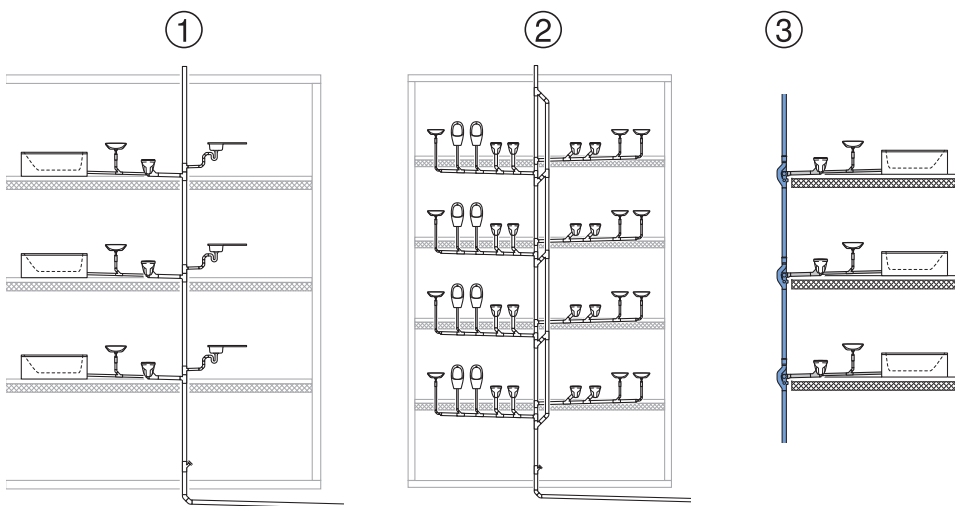

Table 6: The load bearing capacity of Geberit HDPE Sovent in comparison to conventional stack versions

No.	Drainage system	Dimension d	Dimension d of the secondary ventilation	Maximum load in DU (K = 0.5)	Maximum load in l/s
1	Stack vent system with 88.5° branch fitting swept entry	110	–	108	5.2
		125	–	231	7.6
		160	–	615	12.4
2	Secondary ventilation system, direct or indirect, with 88.5° branch fitting swept entry	110	56	185	6.8
		125	75	400	10.0
		160	90	1037	16.1
3	Geberit HDPE Sovent	110	–	576	12.0
		160	–	1156	17.0

3.6 Standards and tests

3.6.1 Standards

The Geberit HDPE Sovent fitting is a special fitting that is based on the requirements of the Swiss standard SN 592000:2012. The reduced velocity aerated systems are also incorporated in the Australian Standards.

Geberit Sovent is included in AN/NZS3500.2.2018 under Reduced Velocity Aerated Stack Systems (RVASS).

All of the pipes and connections attached to a stack with Geberit HDPE Sovent fittings are subject to the regulations of the respective locally applicable standards. The drainage system must therefore be installed in accordance with these regulations. For the stack itself and for the transition of the stack into the collector pipe, Geberit specifies technical parameters which must be adhered to.

The fittings Geberit HDPE Sovent d110, Geberit HDPE BottomTurn bend and Geberit HDPE BackFlip bend use the new Geberit SuperTube technology.

As such, they are outside of the current codes and are to be utilised as a Performance based Alternative Solution.

3.6.2 Tests

Geberit HDPE Sovent has been tested by national test institutes alongside conventional drainage systems. Performance and function of the Geberit HDPE Sovent are documented in the following test reports.

The hydraulic performance and function of fittings with the Geberit SuperTube technology has been confirmed by a test report issued by TÜV Rheinland LGA Products. TÜV Rheinland LGA Products is an independent, internationally recognised test organisation with headquarters in Nuremberg, Germany.

Test reports for Geberit SuperTube

Germany:	TÜV Rheinland LGA Products	Test report 7313368-01 Test report Geberit SuperTube technology (in preparation)
United Kingdom:	BBA	Test report 92/2796 Test report Geberit SuperTube technology (in preparation)
France:	CSTB	Test report 14/16-2201

Test reports for Geberit HDPE Sovent fitting d160

Germany:	TÜV Rheinland LGA Products	Test report 7311212-01
United Kingdom:	BBA	Test report S1/47721

4 Planning

4.1 Planning rules in accordance with Geberit and DIN EN 12056-2:2001-01

4.1.1 Basic rules

When planning discharge pipes with Geberit HDPE Sovent fittings, the following points need to be taken into account in addition to the generally applicable rules for planning discharge pipes:

- Geberit HDPE Sovent fittings should be installed where conventional branch fittings are found in conventional stacks.
- Every stack planned with Geberit HDPE Sovent fittings must terminate directly or by the way of a combined stack vent to atmosphere with no reduction in pipe diameter. Air admittance valves must not be used as primary stack vents.
- The respective planning rules for Geberit HDPE Sovent must be observed for the transition of the stack into a horizontal collector pipe or for the design of a stack offset.

4.1.2 Overview of the pipe sections and rules

Geberit SuperTube d110 pipe sections and rules

The following graphic provides an overview of the pipe sections of a discharge pipe with Geberit SuperTube and the rules which must be observed for these pipe sections.

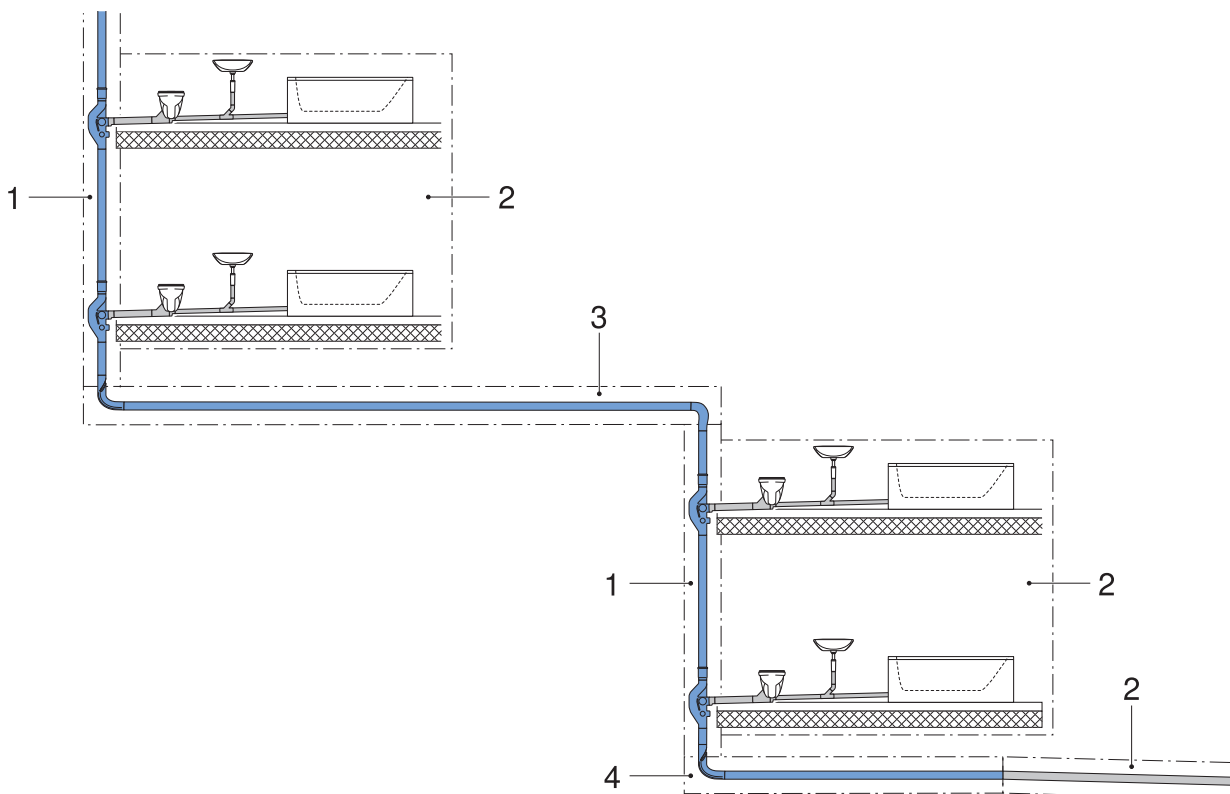

Figure 11: Discharge pipe with Geberit SuperTube: pipe sections and rules

- 1 Stack: planning in accordance with the rules for Geberit HDPE Sovent fittings
- 2 Branch discharge pipes, collector pipe: planning in accordance with local standards
- 3 Stack offset: planning in accordance with the rules for Geberit SuperTube
- 4 Transition to the collector pipe: planning in accordance with the rules for Geberit SuperTube and local standards

Geberit HDPE Sovent d160 pipe sections and rules

The following graphic provides an overview of the pipe sections of a discharge pipe with Geberit HDPE Sovent d160 and the rules which must be observed for these pipe sections.

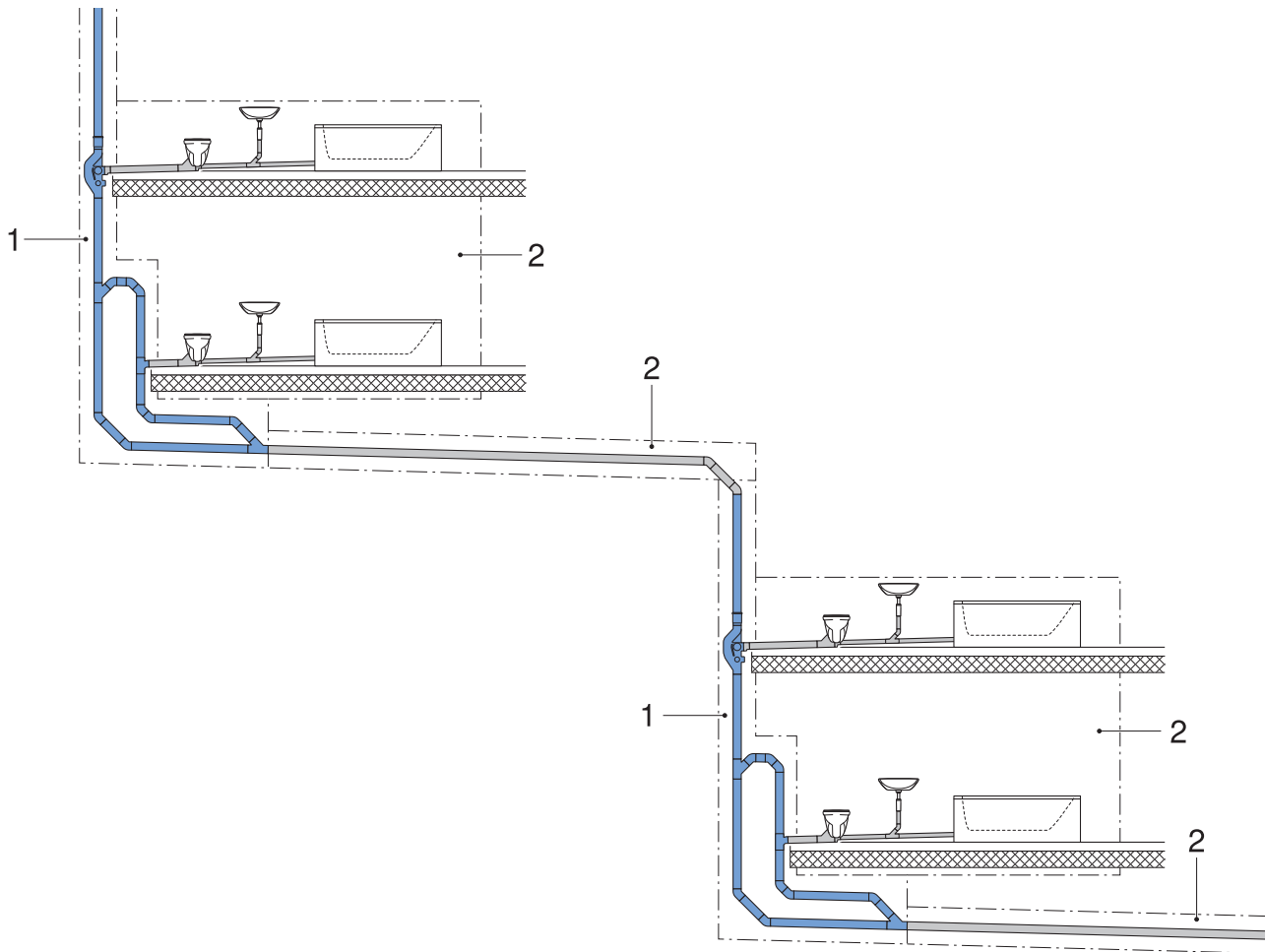

Figure 12: Discharge pipe with Geberit HDPE Sovent d160: pipe sections and rules

- 1 Stack with transitions to the stack offset and collector pipe: planning in accordance with the rules for Geberit HDPE Sovent fittings
- 2 Branch discharge pipes, stack offset, collector pipe: planning in accordance with local standards AS3500.2.

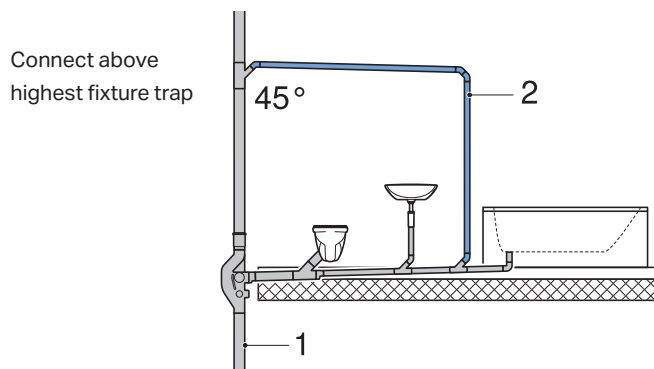

Figure 13: Back Venting

4.1.3 Stack

Load on a stack with Geberit HDPE Sovent fittings

One of the first steps in the planning of a Geberit HDPE Sovent stack is to determine the amount of waste water. All DUs of the appliances must be taken into account for this purpose and included in the configuration of the stack with Geberit HDPE Sovent.

A maximum flow rate of 12 l/s is permitted for stacks with Geberit HDPE Sovent fittings d110 and 17 l/s for stacks with Geberit HDPE Sovent fittings d160. The stack with the stack vent must be implemented completely with d110 or d160.

Table 7: Maximum waste water load of stacks with Geberit HDPE Sovent

Product	Maximum waste water load	Max load DU			
		K=0.5	K=0.7	K=1.0	K=1.2
Sovent d110	12 l/s	576	294	144	100
Sovent d160	17 l/s	1156	590	289	201

Refer to 2.1.4 Drainage Factor K

If the waste water load of stack d110 is greater than 12 l/s, one of the following measures must be planned:

- Use further stacks and distribute the connections accordingly (A, B).
- Use a stack d160 (C, maximum 17 l/s).

Note: Whilst most buildings fall under K factor = 0.5. SuperTube is not suitable if the stack loading exceeds 12 l/s in a single d110 stack (unless the load is split via a second stack). d160 pipe must be used with 160 Sovent. SuperTube is not available for d160 Sovent.

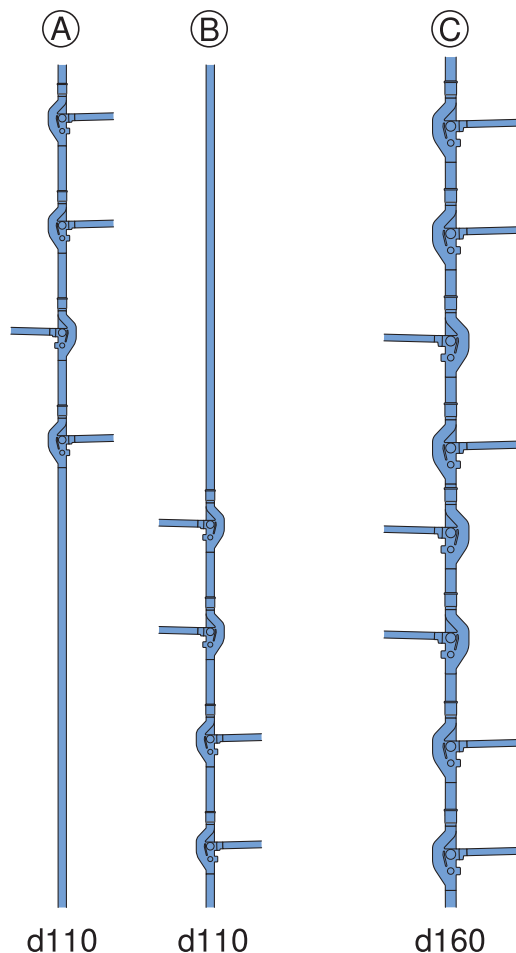

Figure 14: Stacks with Geberit HDPE Sovent with a waste water load greater than 12 l/s

Installing Geberit HDPE Sovent fittings in the stack

A Geberit HDPE Sovent fitting must be installed at every floor connected to the stack.

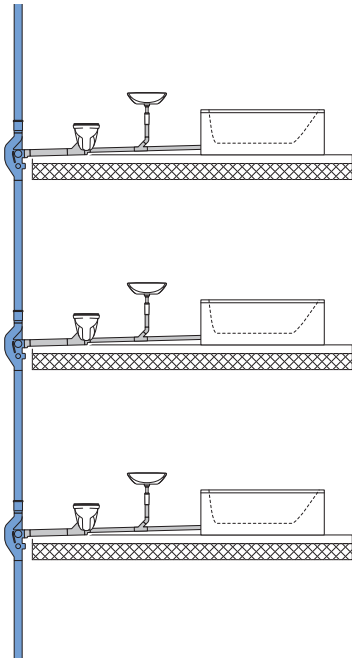
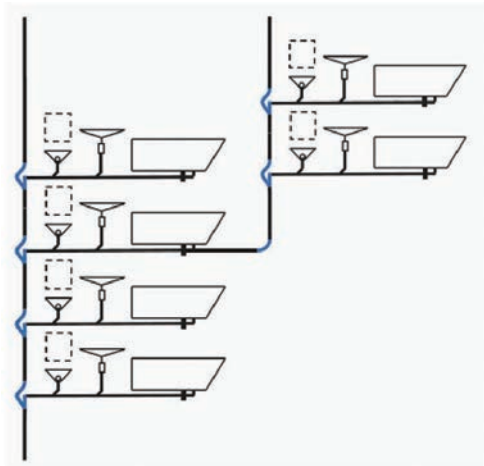

Figure 15: Installing one Geberit HDPE Sovent fitting per floor connection

Stacking branch into stack



Connection is via a Sovent fitting only:

- only 1 connection allowed
- Max. connected DU: 15.0
- Ventilation over roof is mandatory
- D110
- Distance of the stack pipe from main SuperTube stack in min. 2m

Figure 16: Stacking branch into a stack

Horizontally opposite connections are permitted without restriction.
Combinations of connections diagonally opposite one another must be avoided.

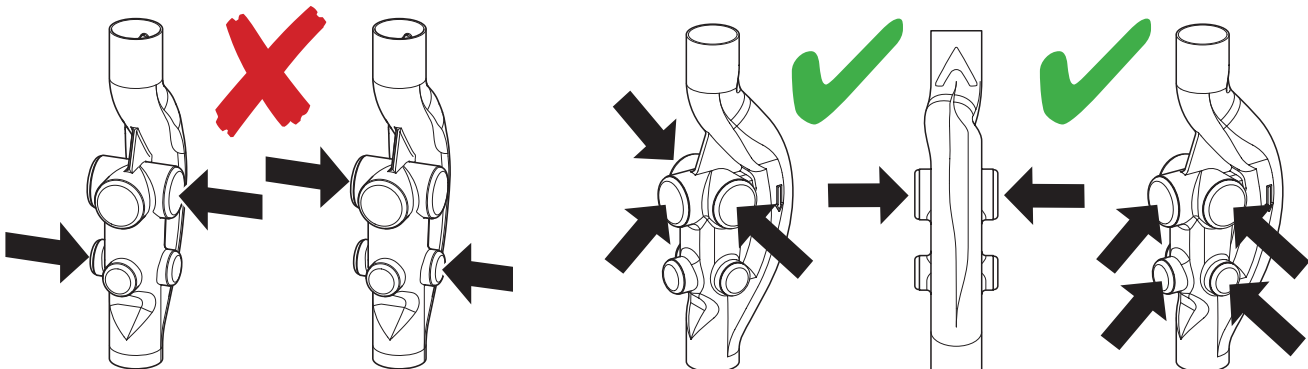

Figure 17: Rules apply to opposed connections to a Sovent fitting in a SuperTube stack

Mixed installation

Only Geberit HDPE Sovent fittings of the same dimension may be installed in a stack. All branch discharge pipes must be connected to the stack through Geberit HDPE Sovent fittings.

The following are not permitted:

- mixed installations of Geberit HDPE Sovent fittings d110 and d160 in the same stack
- mixed installations of Geberit HDPE Sovent fittings with Geberit corner branch fittings or swept-entry corner branch fittings in the same stack

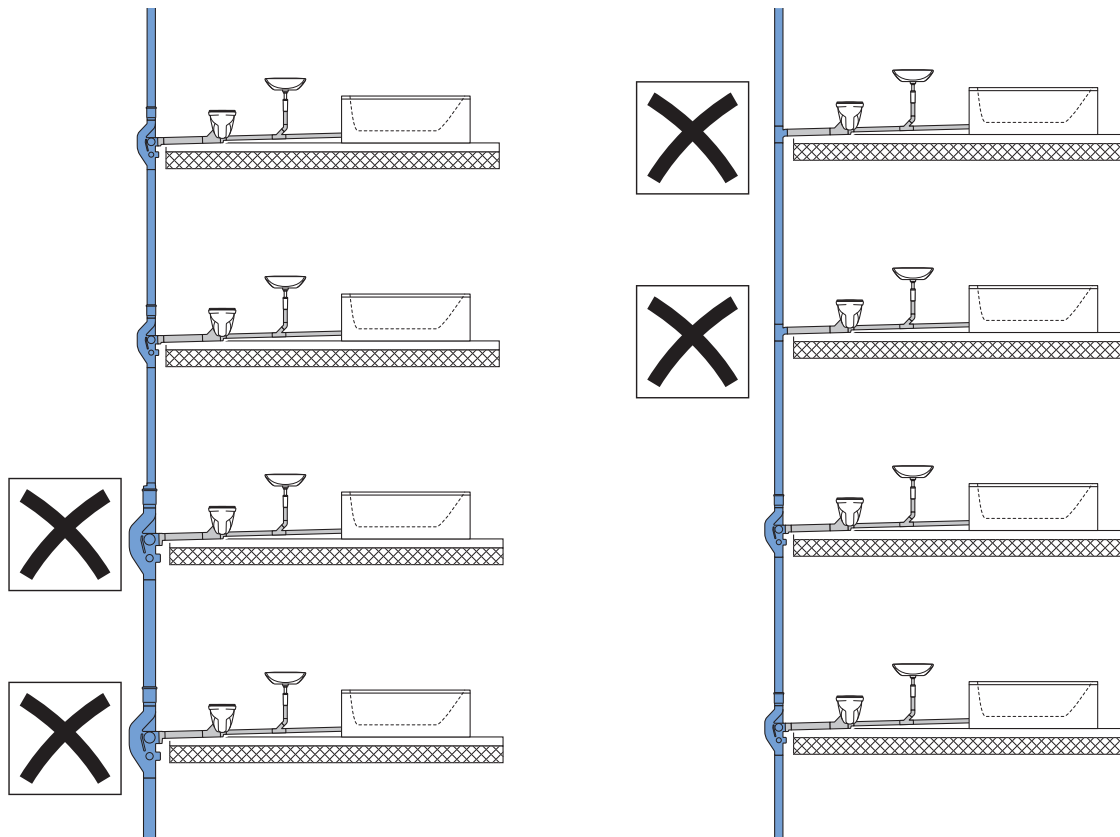

Figure 18: Not permitted – mixed installations of Geberit HDPE Sovent fittings of different dimensions and branch fittings in a stack.

Additional stack connectors

Normally, all water-bearing pipes are connected to the Geberit HDPE Sovent fitting. An exception to this is condensation pipes. Condensation pipes can be connected to the stack between two Geberit HDPE Sovent fittings when the following condition is met:

- The condensate discharge pipe has a maximum dimension of $d63$ mm

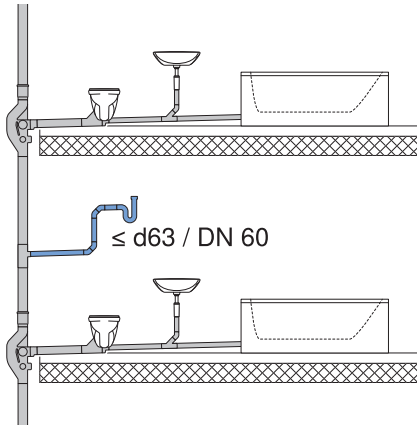

Figure 19: Connection of a condensation pipe $\leq d63$ to the stack between two Geberit HDPE Sovent fittings

Admitting and venting air in stacks

Each stack with Geberit HDPE Sovent fittings must terminate directly or by the way of a combined stack vent to atmosphere with no reduction in pipe diameter. Air admittance valves must not be used as primary stack vents.

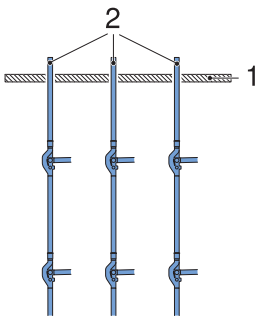

Figure 20: Individual ventilation of stacks with Geberit HDPE Sovent fittings

- 1 Building roof
- 2 Ventilation pipe

If combined ventilation is planned for several stacks, a ventilation collector pipe must be configured in accordance with the applicable local standards and regulations. If the corresponding information is missing, a ventilation collector pipe can be set up in accordance with the following rules:

- A maximum of three stacks can be combined.
- The dimension of the ventilation collector pipe must be increased for each additional stack connector in accordance with the following diagram.

The Use of air admittance valves in Sovent and SuperTube systems

Stack Ventilations

All stacks must be vented to atmosphere. The use of the air admittance valves to vent the stack is not permitted.

Branch Lines

It is permitted to use air admittance valves for the ventilation of fixtures/groups and branch drains as per local standards.

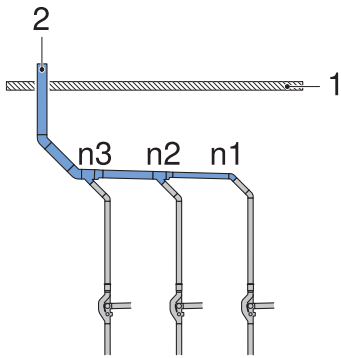

Figure 21: Collective ventilation of stacks with Geberit HDPE Sovent fittings

- 1 Building roof
- 2 Ventilation collector pipe
- n1 Dimension of stack 1
- n2 Dimension of stack 2
- n3 Dimension of stack 3

Table 8: Dimensioning of ventilation collector pipes

Product	Dimension n1	Dimension n2	Dimension n3
Geberit HDPE Sovent fitting d110	ø 110 mm / DN 100	ø 160 mm / DN 150	ø 200 mm / DN 200
Geberit HDPE Sovent fitting d160	ø 160 mm / DN 150	ø 200 mm / DN 200	ø 250 mm / DN 250

Air admittance valves must not be used for stacks with Geberit HDPE Sovent fittings as they can have a negative impact on the discharge capacity of the stack.

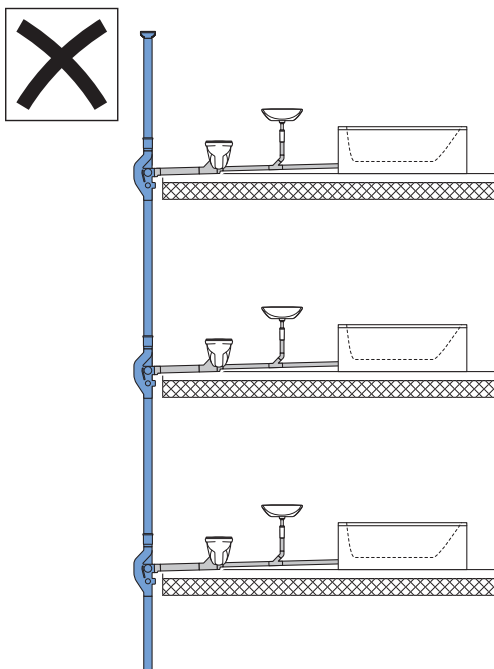

Figure 22: Not permitted – air admittance valves in stacks with Geberit HDPE Sovent fittings

Geberit HDPE Sovent uses the flow-optimised geometry to prevent inadmissible overpressures and negative pressures which impair the correct function of the drainage system.

4.1.4 Branch discharge pipes

Configuration of unvented branch discharge pipes

Maximum 10 meter branch pipes and minimum branch pipe size rules apply (as adopted by AS/N3500.2:2018, Section 11)

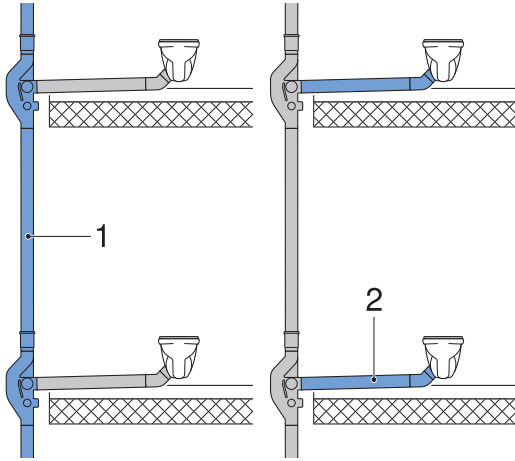

Figure 23: Scope of the branch discharge pipes compared to the stack

- 1 Stack: planning in accordance with the rules for Geberit HDPE Sovent fittings
- 2 Branch discharge pipe: planning in accordance with local standards

Ventilation of branch discharge pipes

Branch ventilation pipes can be connected directly to the stack according to the following diagram.

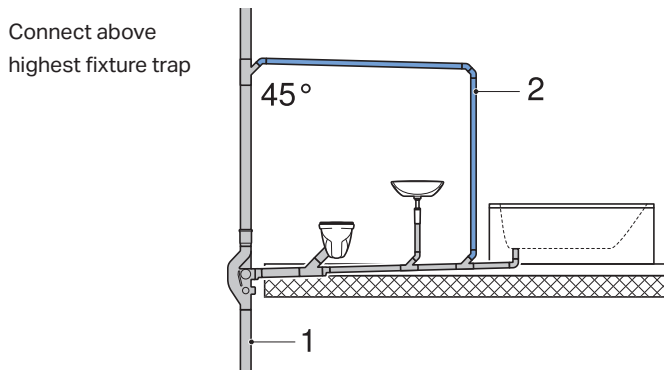

Figure 24: Connection of a branch ventilation pipe to the stack

- 1 Stack in accordance with rules for Geberit HDPE Sovent fittings
- 2 Branch discharge and branch ventilation pipes according to Geberit recommendations DIN EN 12056-2:2001-01

Note: No other vent pipes from other separate drains or other separate stack systems can be connected to the SuperTube system.

Recommended discharge pipe, example 1

In accordance with DIN EN 12056-2:2001-01/SN 592000:2012, the following branch discharge pipe **without secondary ventilation system** is recommended.

Max. permissible DU values	Greatest single DU	DN	Geberit d in mm
1.0	0.5	56	56
2.0	1.0	60	63
3.0 ¹⁾	1.5	70	75
6.5 ²⁾	2.0	90	90
15.0 ²⁾	2.5	100	110

¹⁾ Maximum of two valves with 0.8 DU

²⁾ Maximum of two WCs with 2.0 DU (6-litre flush)

Recommended discharge pipe, example 2

In accordance with DIN EN 12056-2:2001-01/SN 592000:2012, the following branch discharge pipe **with secondary ventilation system** is recommended.

Max. permissible DU values	Greatest single DU	Branch fitting ventilation pipe d in mm	DN	Geberit d in mm
2.0	0.5	56	56	56
3.0 ¹⁾	1.0	56	60	63
4.5	1.5	56	70	75
9.0 ²⁾	2.0	56	90	90
25.0	2.5	56 ³⁾	100	110

¹⁾ Maximum of two valves with 0.8 DU

²⁾ Maximum of two WCs with 2.0 DU (6-litre flush)

³⁾ When DU < 25, the diameter of the branch fitting ventilation pipe is d56. When DU > 25, the diameter of the branch fitting ventilation pipe is d63.

Note: Correctly sized and approved Air Admittance Valves are also an acceptable means of Single and Group Fixture ventilation on branches.

4.1.5 Overview of stack offset

The planning and design of a stack offset in stacks with Geberit HDPE Sovent fittings depend on the following parameters:

- type of fitting/system: Geberit HDPE Sovent d110 or d160 or Geberit SuperTube
- length of stack offset
- branch discharge pipes after the stack offset
- flow rate in the stack

These parameters result in 9 installation situations, for which various planning rules must be observed in terms of the stack offset:

Table 9: Stack offset installation situations in stacks with Geberit HDPE Sovent fittings

Fitting/system	Length of stack offset	Branch discharge pipe	Flow rate
Geberit SuperTube	Up to 1 m	With branch discharge pipe after the stack offset	12 l/s (d110) 17 l/s (d160)
	1-6 m	With branch discharge pipe after the stack offset	12 l/s
	Greater than 6 m	With branch discharge pipe after the stack offset	Up to 4.4 l/s ¹⁾
			Greater than 4.4 l/s ¹⁾
		Without branch discharge pipe after the stack offset	Up to 4.4 l/s ¹⁾
			4.4-7.1 l/s ¹⁾ Greater than 7.1 l/s ¹⁾
Geberit HDPE Sovent d160	Up to 1 m	With branch discharge pipe after the stack offset	12 l/s (d110) 17 l/s (d160)
	1-2 m	With branch discharge pipe after the stack offset	17 l/s
	Greater than 2 m	With branch discharge pipe after the stack offset	17 l/s

¹⁾ With a slope of 3 % and a filling level of 50 %

4.1.6 Geberit HDPE Sovent d110 or d160 stack offset up to 1 m

A stack offset of up to 1 m can be installed without requiring any further measures. Bends up to a maximum of 45° must be used for changes in pipe direction.

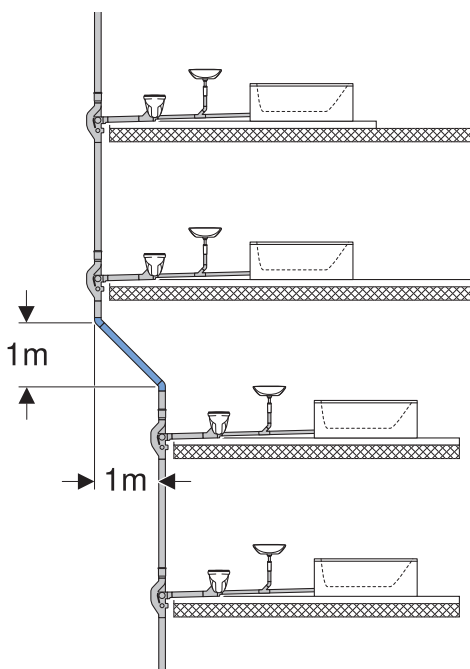

Figure 25: Structure of a stack offset with an offset of up to 1 m

If the stack offset is greater than 1 m, a branch ventilation pipe must be installed in the same way as the stack offset.

4.1.7 Geberit SuperTube d110 stack offset greater than 1 m

Stack offset 1–6 m

For a flow rate up to 12 l/s (with a $\geq 0\%$ slope), the stack offset must be structured in accordance with the following diagram. Horizontal changes in pipe direction are not permitted.

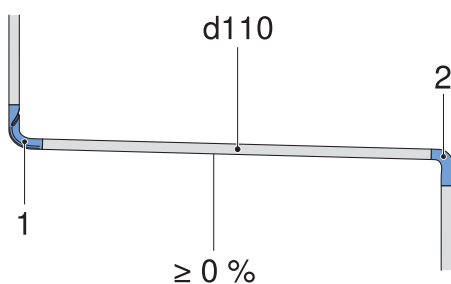

Figure 26: Structure of a stack offset 1–6 m in a stack with Geberit SuperTube

- 1 Geberit HDPE BottomTurn bend
- 2 Geberit HDPE BackFlip bend

Stack offset greater than 6 m with connection after offset, flow rate up to 4.4 l/s

At a flow rate of up to 4.4 l/s (with a 3 % slope and 50 % filling level), the stack offset must be structured as follows:

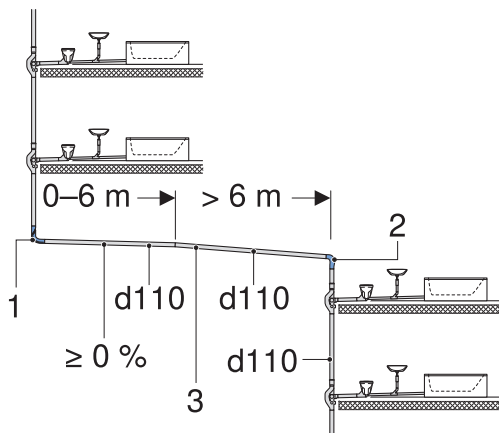

Figure 27: Structure of a stack offset greater than 6 m in a stack with Geberit SuperTube, with branch discharge pipe after stack offset, flow rate of up to 4.4 l/s (with 3 % slope and 50 % filling level)

- 1 Geberit HDPE BottomTurn bend
- 2 Geberit HDPE BackFlip bend
- 3 Slope in accordance with local standard or DIN EN 12056-2:2001-01

Stack offset greater than 6 m with connection after offset, flow rate greater than 4.4 l/s

At a flow rate greater than 4.4 l/s (with a 3 % slope and 50 % filling level), one of the following measures must be planned:

- Divide stack into two stacks with Geberit SuperTube.
- Use a stack with Geberit HDPE Sovent d160 (maximum 17 l/s).

Stack offset greater than 6 m without connection after offset, flow rate up to 4.4 l/s

At a flow rate of up to 4.4 l/s (with a 3 % slope and 50 % filling level), the stack offset must be structured as follows:

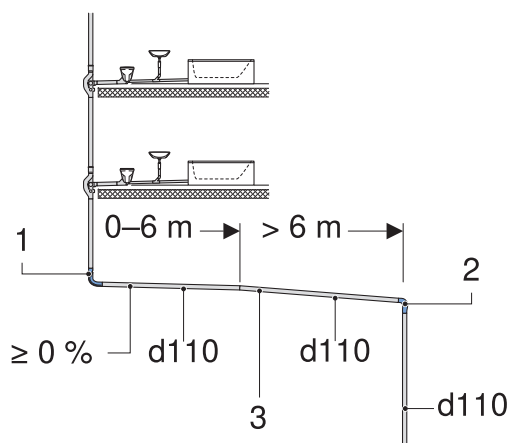

Figure 28: Structure of a stack offset greater than 6 m in a stack with Geberit SuperTube, without branch discharge pipe after stack offset, flow rate of up to 4.4 l/s (with 3 % slope and 50 % filling level)

- 1 Geberit HDPE BottomTurn bend
- 2 Geberit HDPE BackFlip bend
- 3 Slope in accordance with local standard or DIN EN 12056-2:2001-01

Stack offset greater than 6 m without connection after offset, flow rate 4.4–7.1 l/s

At a flow rate of 4.4–7.1 l/s (with a 3 % slope and 50 % filling level), the stack offset must be structured as follows:

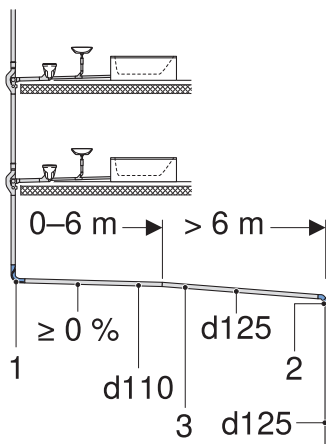

Figure 29: Structure of a stack offset greater than 6 m in a stack with Geberit SuperTube, without branch discharge pipe after stack offset, flow rate 4.4–7.1 l/s (with 3 % slope and 50 % filling level)

- 1 Geberit HDPE BottomTurn bend
- 2 2 x 45° bends
- 3 Slope in accordance with DIN EN 12056-2:2001-01

Stack offset greater than 6 m without connection after offset, flow rate greater than 7.1 l/s

At a flow rate greater than 7.1 l/s (with a 3 % slope and 50 % filling level), the stack offset must be structured as follows:

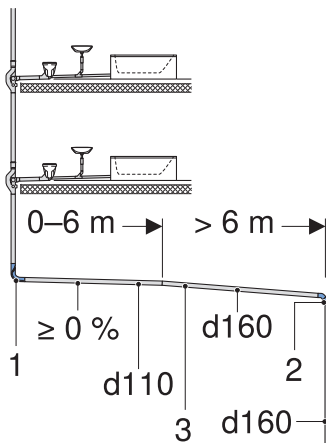

Figure 30: Structure of a stack offset greater than 6 m in a stack with Geberit SuperTube, without branch discharge pipe after stack offset, flow rate greater than 7.1 l/s (with 3 % slope and 50 % filling level)

- 1 Geberit HDPE BottomTurn bend
- 2 2 x 45° bends
- 3 Slope in accordance with DIN EN 12056-2:2001-01

4.1.8 Geberit HDPE Sovent d160 stack offset greater than 1 m

Stack offset 1–2 m

A stack offset of 1–2 m must be structured in accordance with the following diagram. A branch ventilation pipe d110 is required to relieve pressure.

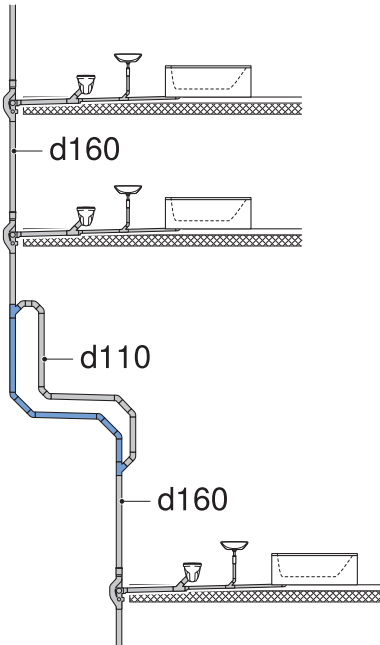

Figure 31: Structure of a stack offset 1–2 m in a stack with Geberit HDPE Sovent d160

Stack offset greater than 2 m

A stack offset greater than 2 m must be structured in accordance with the following diagram. A branch ventilation pipe d110 is required to relieve pressure.

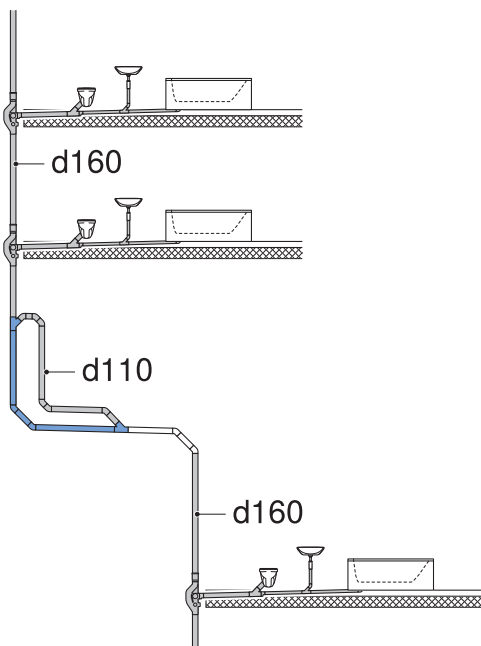

Figure 32: Structure of a stack offset greater than 2 m in a stack with Geberit HDPE Sovent d160

4.1.9 Zones without connections

Geberit SuperTube d110 zones without connections

After a direction change, the zones without connections must be observed in accordance with the following diagrams:

Structure without connections into the stack offset:

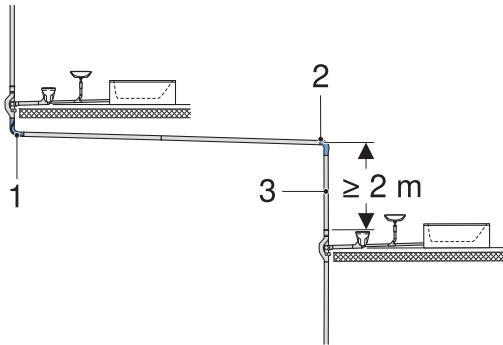

Figure 33: Zone without connections Geberit SuperTube with a stack offset without connections into the stack offset

- 1 Geberit HDPE BottomTurn bend
- 2 Geberit HDPE BackFlip bend
- 3 Zone without connection: upper edge of Geberit HDPE Sovent fitting up to pipe axis

Structure with connections into the stack offset:

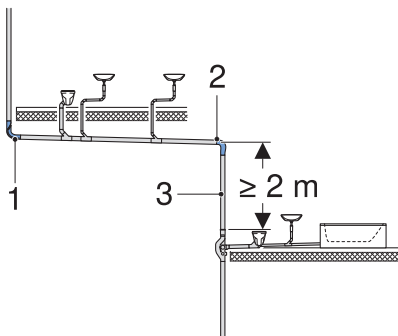

Figure 34: Zone without connections Geberit SuperTube with a stack offset with connections into the stack offset

- 1 Geberit HDPE BottomTurn bend
- 2 Geberit HDPE BackFlip bend
- 3 Zone without connection: upper edge of Geberit HDPE Sovent fitting up to pipe axis

Geberit HDPE Sovent d160 zones without connections

Before and after a direction change, the zones without connections must be observed in accordance with the following diagrams:

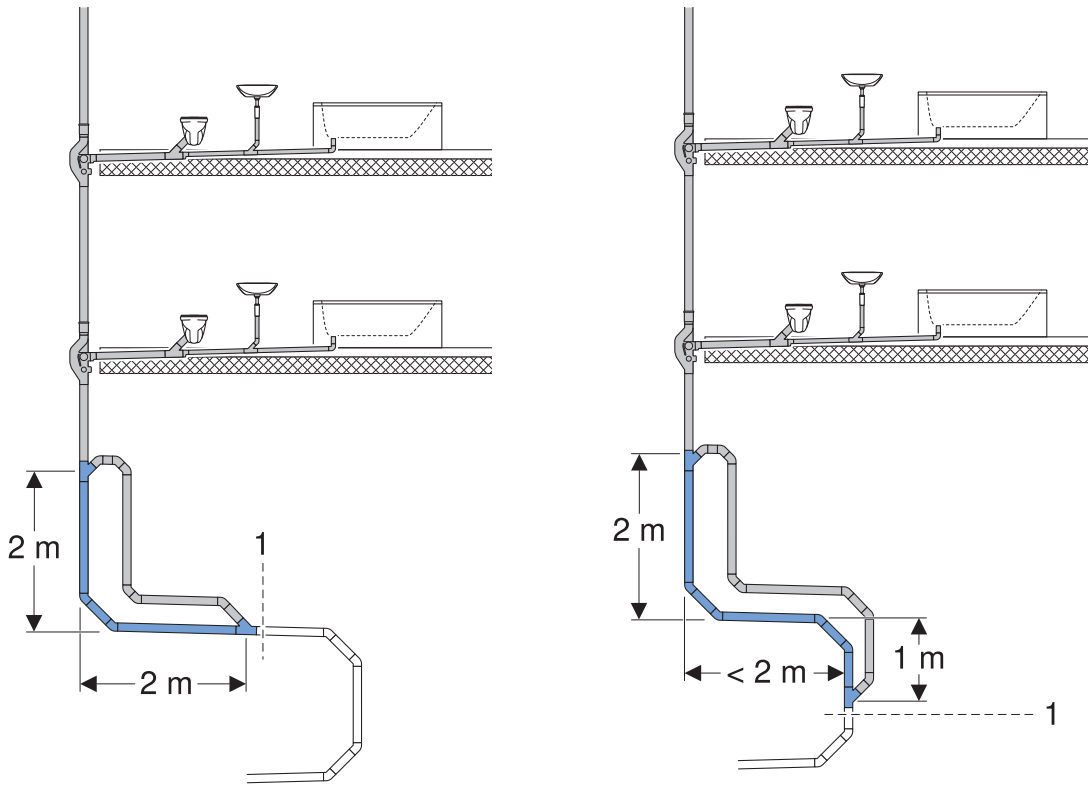

Figure 35: Zone without connections with a stack offset d160

1 Base of the pipe system with Geberit HDPE Sovent fittings

Zones without connections must be installed before the direction change into the underground pipe or the collector pipe if sanitary appliances are connected to the stack in order to prevent backing up. The sanitary appliances must be connected to a branch ventilation pipe d110.

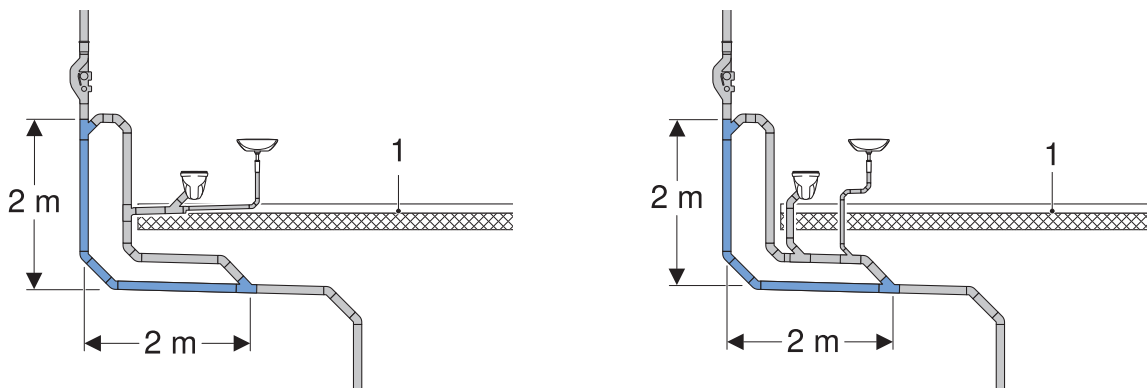

Figure 36: Zone without connections with a stack offset d160 with branch discharge pipes before the direction change into the underground or collector pipe

1 First floor

The subsequent pipe layout is planned in accordance with local standards.

4.1.10 Transition to the collector pipe

Geberit SuperTube d110 transition to the collector pipe

For the transition of a stack with Geberit SuperTube to the collector pipe, a Geberit HDPE BottomTurn bend must be installed at the base of the stack. The connecting stack (maximum 6 m) is to be executed up to the system boundary without horizontal direction change.

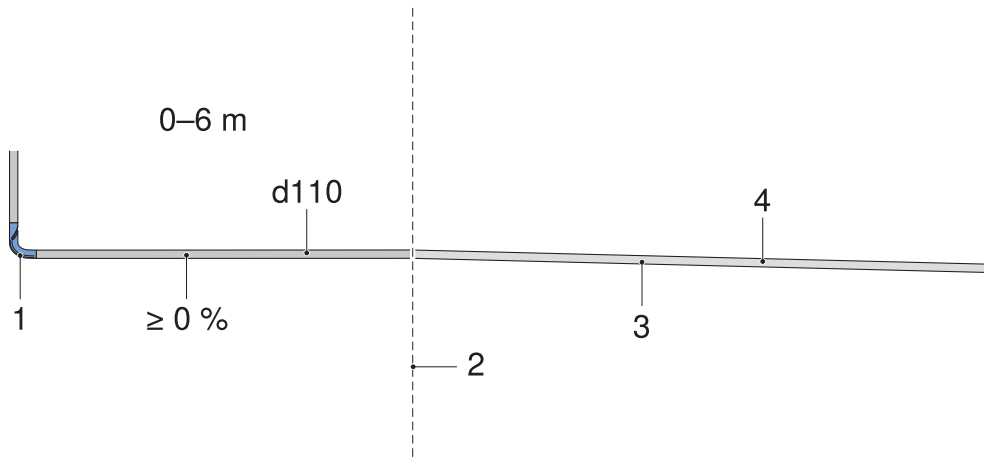

Figure 37: Transition of a stack with Geberit SuperTube to the collector pipe

- 1 Geberit HDPE BottomTurn bend
- 2 System boundary
- 3 Slope in accordance with local standard or in accordance with DIN EN 12056-2:2001-01
- 4 Dimensioning in accordance with local standard or in accordance with DIN EN 12056-2:2001-01

If several stacks with Geberit SuperTube are connected to one collector pipe, a Geberit HDPE BottomTurn bend must be installed at the base of each stack. The connecting stack (maximum 6 m) is to be executed up to the system boundary without horizontal direction change.

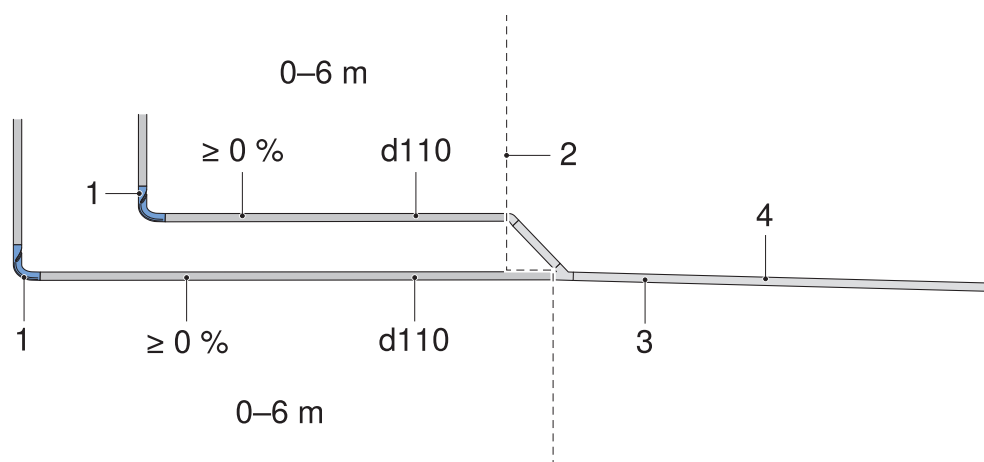

Figure 38: Connection of several stacks with Geberit SuperTube to the collector pipe

- 1 Geberit HDPE BottomTurn bend
- 2 System boundary
- 3 Slope in accordance with local standard or in accordance with DIN EN 12056-2:2001-01
- 4 Dimensioning in accordance with local standard or in accordance with DIN EN 12056-2:2001-01

Transition to the collector pipe Geberit HDPE Sovent d160

For the transition of a stack with Geberit HDPE Sovent fittings d160 to the collector pipe, a branch ventilation pipe d110 must be installed at the base of the stack to reduce any potential overpressure.

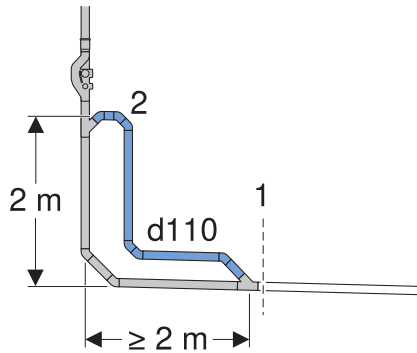

Figure 39: Transition of a stack with Geberit HDPE Sovent fittings d160 to the collector pipe

- 1 Base of the pipe system with Geberit HDPE Sovent fittings
- 2 Branch ventilation pipe for pressure relief

4.2 Planning rules in accordance with AS/NZS 3500.2:2018 d110 & d160 Sovent (non SuperTube)

4.2.1 Basic rules

When planning sanitary stack and branch discharge pipes with Geberit HDPE Sovent fittings in accordance with AS/NZS 3500.2:2018, the following rules must be observed:

- All sanitary appliances must be connected to the stack through a Geberit HDPE Sovent fitting.
- A de-aerator and pressure relief bypass pipe shall be installed at the transition to the collector pipe and at all stack offsets.
- All stacks must terminate directly or by way of a combined stack vent to atmosphere with no reduction in pipe diameter. Air admittance valves must not be used as primary stack vents.

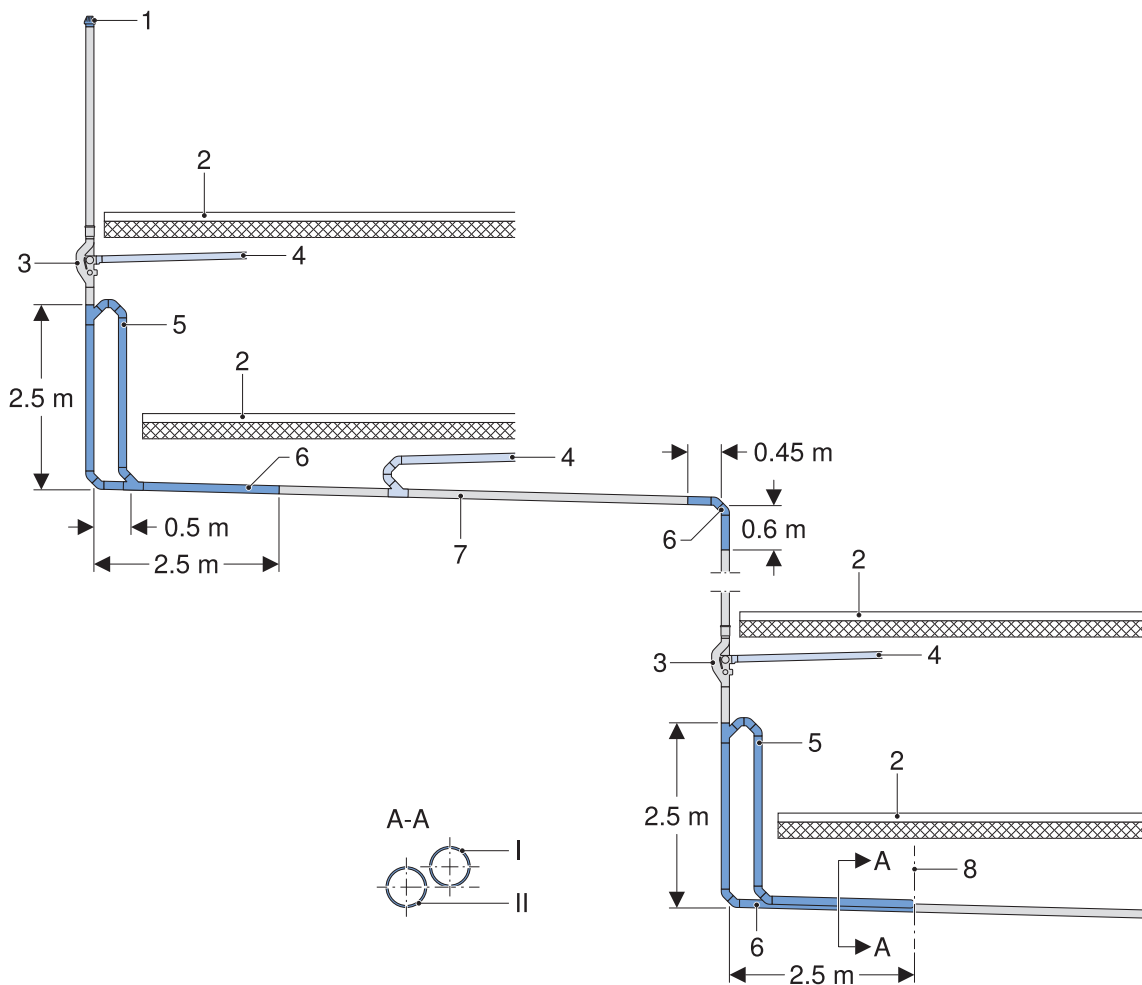

Figure 40: Discharge pipe with Geberit HDPE Sovent fittings: planning rules

- 1 Ventilation to the outdoors
- 2 Building floor
- 3 Geberit HDPE Sovent fitting
- 4 Branch discharge pipe
- 5 Pressure relief bypass pipe
- 6 Zone without connection
- 7 Stack offset
- 8 Base of the stack
- I Pressure relief bypass pipe
- II Drainage pipe

4.2.2 Configuration of branch discharge pipes

Sanitary appliances must be connected to any or all of the 6 connection points of the Geberit HDPE Sovent fitting via branch discharge pipes.

Opposed connections of the Geberit HDPE Sovent fitting shall only be used when equivalent sanitary appliances of the same type are connected (AS/NZS 3500.2:2018, Clause 11.6.2).

4.2.3 Ventilation of branch discharge pipes

The length and size of non-ventilated branch discharge pipes shall be in accordance with AS/NZS 3500.2:2018.

Branch discharge pipes that exceed the maximum length or loading unit shall be vented to atmosphere or via an appropriate air admittance valve.

4.2.4 Load on a stack with Geberit HDPE Sovent fittings

The total waste water load for all stacks must be calculated using Fixture Unit Ratings (AS/NZS 3500.2:2018, Table 6.3(A) and 6.3(B)). All sanitary appliances connected to the stack are included to determine the total waste water load.

Stacks shall be sized in accordance with AS/NZS 3500.2:2018, Clause 11.3.

In accordance with AS/NZS 3500.2:2018, Table 8.2.2(A), a straight stack shall not exceed the following values:

- with Geberit HDPE Sovent d110: 500 FU
- with Geberit HDPE Sovent d160: 2400 FU

Where the size of a stack is increased due to an offset, the stack shall not be reduced in size in any direction.

4.2.5 Installing Geberit HDPE Sovent fittings in the stack

A Geberit HDPE Sovent fitting must be installed at every floor connected to the stack. The distance between two Geberit HDPE Sovent fittings must not exceed 5 m.

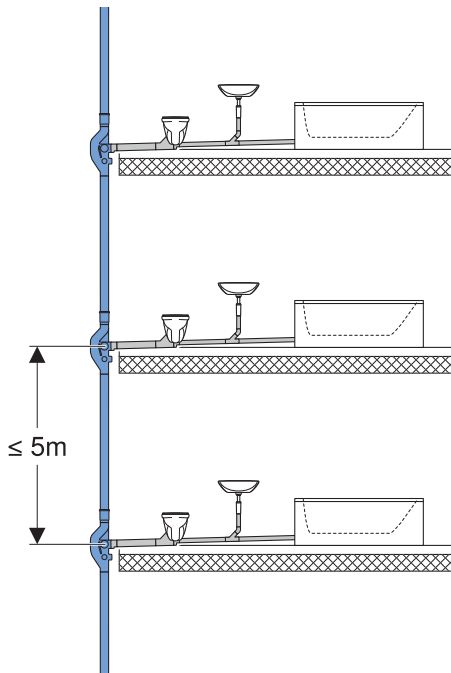

Figure 41: Installing one Geberit HDPE Sovent fitting per floor connection

If the distance between two Geberit HDPE Sovent fittings is greater than 5 m, install an offset using two 45° bends. No straight pipe sections are allowed in the offset.

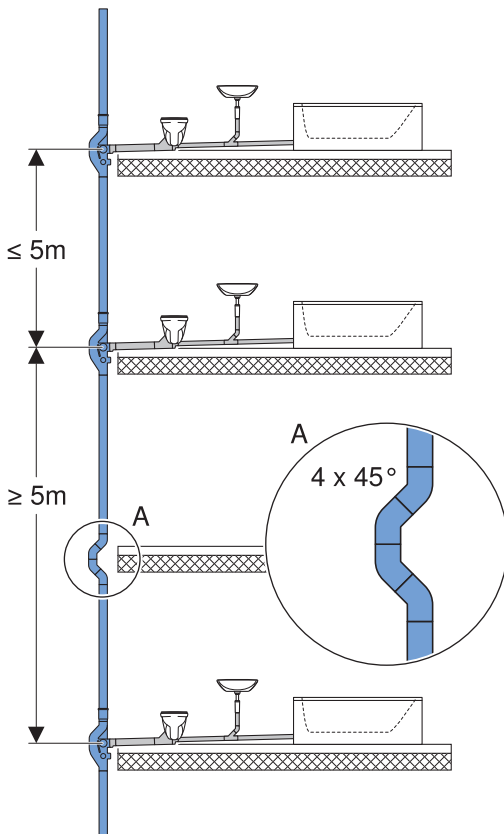

Figure 42: Installing an offset using two 45° bends

4.2.6 Installing several stacks

If the waste water load of stack d110 is greater than 500FU, one of the following measures must be planned:

- Use further stacks and distribute the connections accordingly (A, B).
- Use a stack d160 (C, maximum 2400FU).

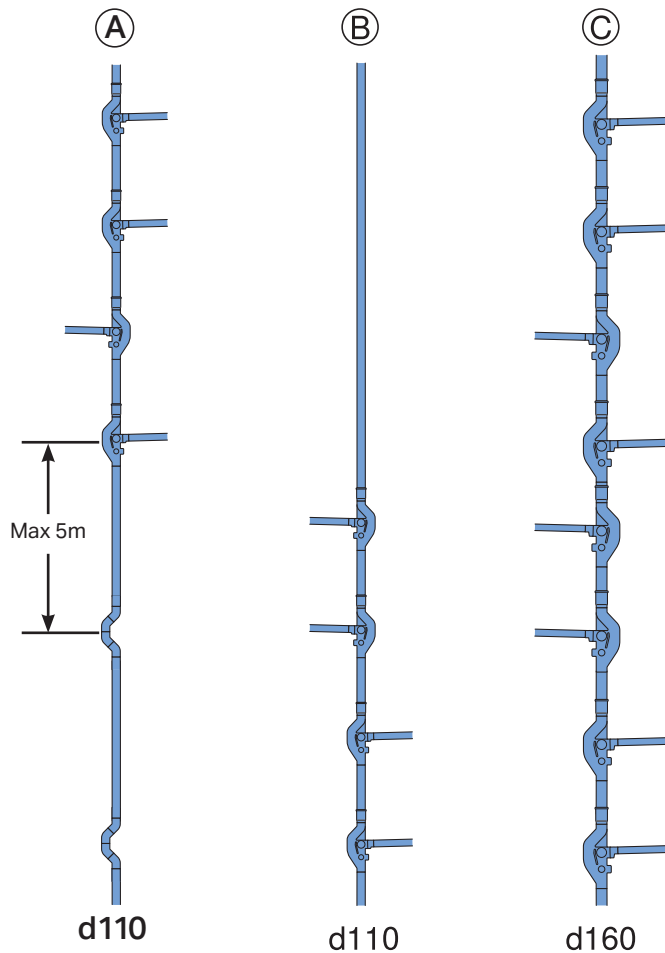

Figure 43: Stacks with Geberit HDPE Sovent with a waste water load greater than 500FU.

If the waste water load exceeds 2400 FU for the stack d160, stack segmentation may be required.

4.2.7 Transition to the collector pipe

For the transition of a stack with Geberit HDPE Sovent fittings d110 or d160 to the collector pipe, a de-aerator with pressure relief bypass pipe d110 must be installed at the base of the stack to reduce any potential overpressure (AS/NZS 3500.2:2018, Clause 11.9 and 8.6.2.3).

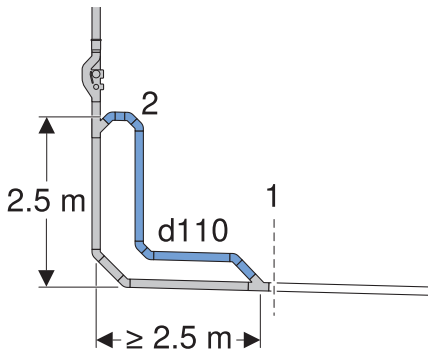

Figure 44: Transition of a stack with Geberit HDPE Sovent fittings d110 or d160 to the collector pipe

- 1 Base of the pipe system with Geberit HDPE Sovent fittings
- 2 Pressure relief bypass pipe

4.2.8 Connections at the base of the stack

Connections to the de-aerator or pressure relief bypass pipes are not permitted in accordance with AS/NZS 3500.2:2018, Clause 11.9. Alternative connection points must be sought.

4.2.9 Vertical to horizontal transition of the stack

The transition of the stack from the vertical to the horizontal direction must be structured in accordance with the following diagrams:

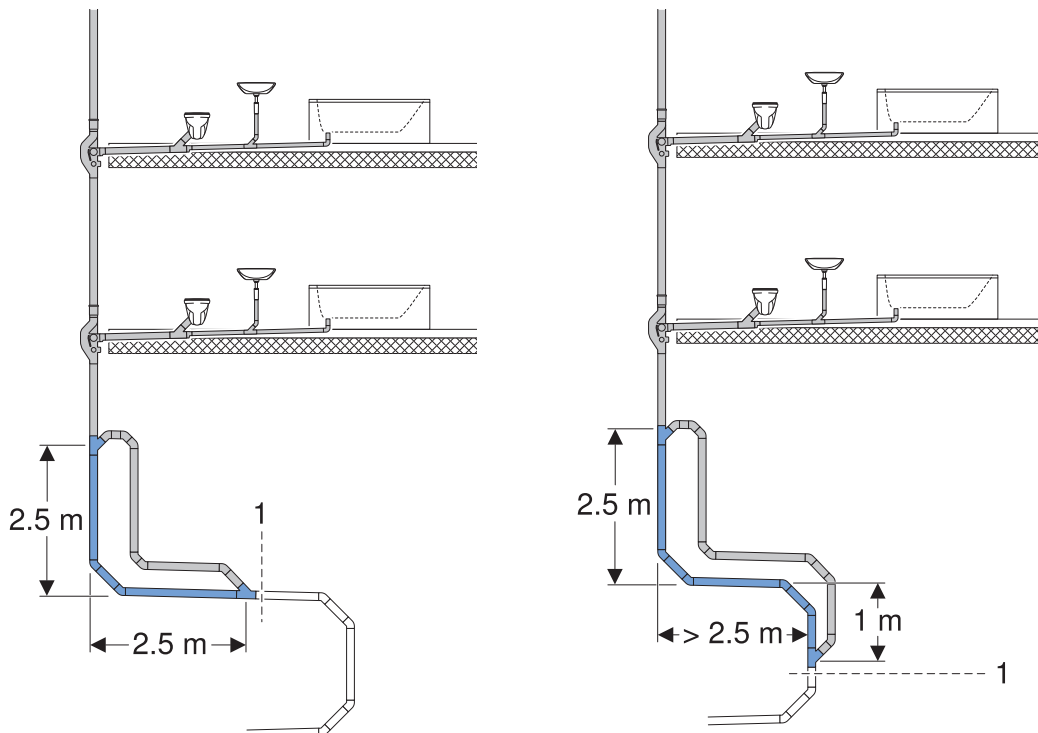

Figure 45: Vertical to horizontal transition of the stack

- 1 Base of the pipe system with Geberit HDPE Sovent fittings

4.2.10 Stack offset

Stack offsets shall be sized in accordance with AS/NZS 3500.2:2018, Clause 11.5.

4.2.11 Mixed installation

Mixed installations of Geberit HDPE Sovent fittings d110 and d160 are not permitted in the same stack.

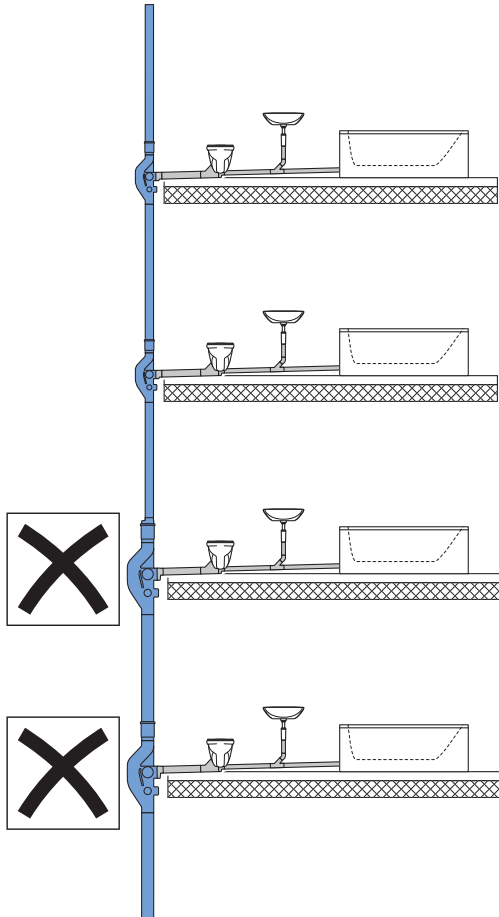

Figure 46: Not permitted – mixed installations of Geberit HDPE Sovent fittings with different dimensions

4.2.12 Connection to the collector pipe

The Geberit HDPE Sovent stack must be drained through a connection to an underground or collector pipe. The connection to the underground or collector pipe must be made in accordance with AS/NZS 3500.2:2018, Table 3.3.1.

If the diameter of the stack is smaller than the connection point to the collector pipe, a reducer must be installed into the stack in accordance with AS/NZS 3500.2:2018, Figure 6.7.3(a).

4.2.13 Collective ventilation of stacks

Refer to AS/NZS 3500.2:2018, Clause 11.4 and Figure 11.4(A) for collective ventilation of stacks.

4.2.14 The use of air admittance valves

Stacks with Geberit HDPE Sovent fittings shall be ventilated unimpeded to atmosphere. The use of air admittance valves is not permitted. Air admittance valves may only be used to ventilate branch discharge pipes.

4.3 Dimensioning SuperTube d110, Sovent d160

4.3.1 Principles

The maximum admissible flow rate of a stack with Geberit HDPE Sovent fittings is:

- d110 (DN 100): 12 l/s
- d160 (DN 150): 17 l/s

If the flow rate in the stack falls below the maximum admissible flow rate, the stack can be dimensioned with the corresponding pipe diameter. If the flow rate exceeds the flow capacity, a second stack must be planned or the dimensions of stack d110 must be increased in size.

4.3.2 Sample calculations

Determination of the maximum number of residential apartments based on the loading unit DU

Given:

- typical residential apartment: 2 bath group, kitchen with dishwasher and laundry with washing machine = 11.5 DU
- $Q_{\max \text{ Sovent d110}} = 12 \text{ l/s} = 576 \text{ DU}$
- $Q_{\max \text{ Sovent d160}} = 17 \text{ l/s} = 1156 \text{ DU}$

Required:

- maximum number N_{\max} for residential apartments for one stack with Geberit HDPE Sovent

Solution:

- $N_{\max \text{ Sovent d110}} = Q_{\max \text{ Sovent d110}} / Q_{\text{Residential apartment}} = 576 \text{ DU} / 11.5 \text{ DU} = 50 \text{ residential apartments}$
- $N_{\max \text{ Sovent d160}} = Q_{\max \text{ Sovent d160}} / Q_{\text{Residential apartment}} = 1156 \text{ DU} / 11.5 \text{ DU} = 100 \text{ residential apartments}$

Stack in residential building with 40 floors

Given:

- residential building with 40 floors
- two apartments per floor
- sanitary appliances per apartment:
 - 1 kitchen sink
 - 1 bathtub
 - 2 washbasins at 0.5 DU
 - 1 WC system 6 l
- drainage factor $K = 0.5$

Required:

- pipe dimension of the stack
- number of stacks

Solution:

1. Calculation of DU discharge units

Number	Sanitary appliance	DU
1	Kitchen sink	0.8
1	Bathtub	0.8
2	Washbasin at 0.5 DU	1.0
1	WC system 6 l	2.0
	Total per apartment	4.6
	Total per floor	9.2
	Total for residential building	368

2. Calculation of the flow rate (waste water load) in the stack

$$\begin{aligned}
 Q_s &= K \cdot \sqrt{\sum DU} \\
 &= 0.5 \cdot \sqrt{368} \\
 &= \mathbf{9.59 \text{ l/s}}
 \end{aligned}$$

3. Compare Q_s with $Q_{\max \text{ Sovent}}$

Q_s (9.59 l/s) is smaller than $Q_{\max \text{ Sovent d110}}$ (12 l/s).

Result

The residential building can be drained using **one** stack \varnothing **110 mm** (DN 100).

Stack in residential building with 120 floors

Given:

- residential building with 120 floors
- two apartments per floor
- sanitary appliances per apartment:
 - 1 kitchen sink
 - 1 bathtub
 - 2 washbasins at 0.5 DU
 - 1 WC system 6 l
- drainage factor $K = 0.5$

Required:

- pipe dimension of the stack
- number of stacks

Solution:

1. Calculation of DU discharge units

Number	Sanitary appliance	DU
1	Kitchen sink	0.8
1	Bathtub	0.8
2	Washbasin at 0.5 DU	1.0
1	WC system 6 l	2.0
	Total per apartment	4.6
	Total per floor	9.2
	Total for residential building	1104.0

2. Calculation of the flow rate (waste water load) in the stack

$$\begin{aligned}
 Q_s &= K \cdot \sqrt{\sum DU} \\
 &= 0.5 \cdot \sqrt{1104} \\
 &= \mathbf{16.6 \text{ l/s}}
 \end{aligned}$$

3. Compare Q_s with $Q_{\max \text{ Sovent}}$

Q_s (16.6 l/s) is greater than $Q_{\max \text{ Sovent d110}}$ (12 l/s) and smaller than $Q_{\max \text{ Sovent d160}}$ (17 l/s).

Result

The residential building must be drained using **two** stacks \varnothing 110 mm (DN 100) or with **one** stack \varnothing 160 mm (DN 150).

Underground or collector pipe with several stacks

Given:

- building with three stacks \varnothing 160 mm (DN 150) with Geberit HDPE Sovent fittings d160

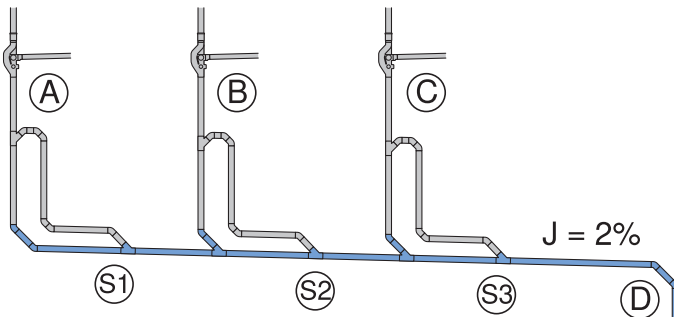

- A Stack A
- B Stack B
- C Stack C
- D Collector pipe
- S1 Section 1
- S2 Section 2
- S3 Section 3
- J Slope

- waste water load per stack:
 - stack A: $\Sigma DU_A = 800$
 - stack B: $\Sigma DU_B = 750$
 - stack C: $\Sigma DU_C = 820$
- filling level of the underground or collector pipe = 50 %
- slope of the underground or the collector pipe = 2 %
- drainage factor $K = 0.5$

Required:

- pipe dimension of the collector pipe (sections S1–S3)

Solution:

1. Calculation of the waste water load of sections S1–S3

$$\begin{aligned} \text{Section 1} &= K \cdot \sqrt{\Sigma DU_A} \\ &= 0.5 \cdot \sqrt{800} &= 14.1 \text{ l/s} \end{aligned}$$

$$\begin{aligned} \text{Section 2} &= K \cdot \sqrt{\Sigma DU_A + \Sigma DU_B} \\ &= 0.5 \cdot \sqrt{1550} &= 19.7 \text{ l/s} \end{aligned}$$

$$\begin{aligned} \text{Section 3} &= K \cdot \sqrt{\Sigma DU_A + \Sigma DU_B + \Sigma DU_C} \\ &= 0.5 \cdot \sqrt{2370} &= 24.4 \text{ l/s} \end{aligned}$$

2. Calculation of the pipe dimensions of sections S1–S3

The pipe dimension of sections S1–S3 depends on the filling level and on the slope of the pipe. It is calculated in accordance with DIN EN 12056-2:2001-01, as shown in the following table:

Table 4: Maximum waste water load in l/s for underground pipes or collector pipes at a filling level of 50% depending on pipe dimension and slope in accordance with DIN EN 12056-2:2001-01

Slope J								
1% (1 : 100)	1.5% (1 : 66)	2% (1 : 50)	2.5% (1 : 40)	3% (1 : 33)	3.5% (1 : 28)	4% (1 : 25)	5% (1 : 20)	Pipe dimension \varnothing [mm] / DN
2.5	3.1	3.5	4.0	4.4	4.7	5.0	5.6	110/100
4.1	5.0	5.7	6.4	7.1	7.6	8.2	9.1	125/125
7.7	9.4	10.9	12.2	13.3	14.4	15.4	17.2	160/150
14.2	17.4	20.1	22.5	24.7	26.6	28.5	31.9	200/200
26.9	32.9	38.1	42.6	46.7	50.4	53.9	60.3	250/250
48.3	59.2	68.4	76.6	83.9	90.7	96.6	108.4	315/300

Key:

1. Select column with the specified slope: 2 % column
2. Select the next greatest waste water value:
 - a) Section 1: calculated waste water value = 14.1 l/s
 - b) Section 1: next greatest waste water value: 20.1 l/s
 - c) Section 2: calculated waste water value = 19.7 l/s
 - d) Section 2: next greatest waste water value: 20.1 l/s
 - e) Section 3: calculated waste water value = 24.4 l/s
 - f) Section 3: next greatest waste water value: 38.1 l/s
3. Select the pipe dimension corresponding to the next greatest waste water value:
 - a) Section 1: \varnothing 200 mm (DN 200)
 - b) Section 2: \varnothing 200 mm (DN 200)
 - c) Section 3: \varnothing 250 mm (DN 250)

5 Installation

5.1 Installation rules

5.1.1 Basic rules

The same rules apply to mounting the Geberit HDPE Sovent fittings as for the mounting of all other Geberit HDPE fittings.

In addition, the following rules must be taken into account for the mounting of the Geberit HDPE Sovent fittings:

- Connection pipes can only be connected using a butt-welding connection to the Sovent fitting.
- Geberit HDPE Sovent fittings may be installed only in the direction of flow. The direction of flow is indicated by an arrow on the fittings.

5.1.2 Prefabrication

Connecting Geberit HDPE pipes and fittings to the Geberit HDPE Sovent fitting with electrofusion couplings or butt welding for prefabrication.

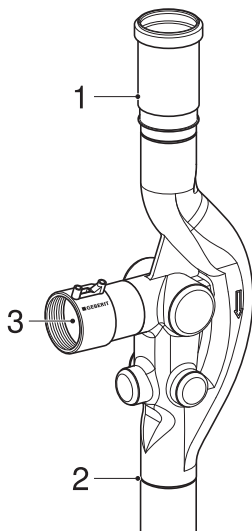

- 1 Expansion socket: connection with butt welding (electrofusion welding also possible)
- 2 Pipe for the stack extension: connection with butt welding (electrofusion welding also possible)
- 3 Branch discharge pipe: connection with electrofusion welding at previously attached connection piece (butt welding also possible)

5.2 Installation manual

5.2.1 Connecting Geberit HDPE Sovent fitting with pipe section

- 1** Saw open the required lateral connection.

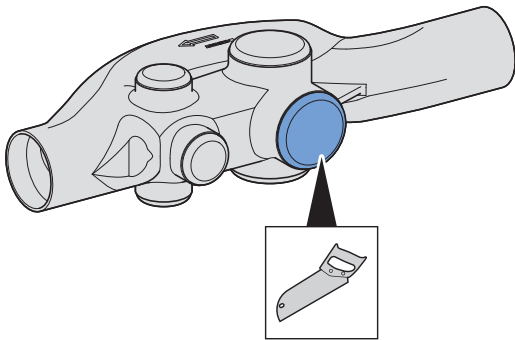

- 2** Clamp the Geberit HDPE Sovent fitting into the welding machine.

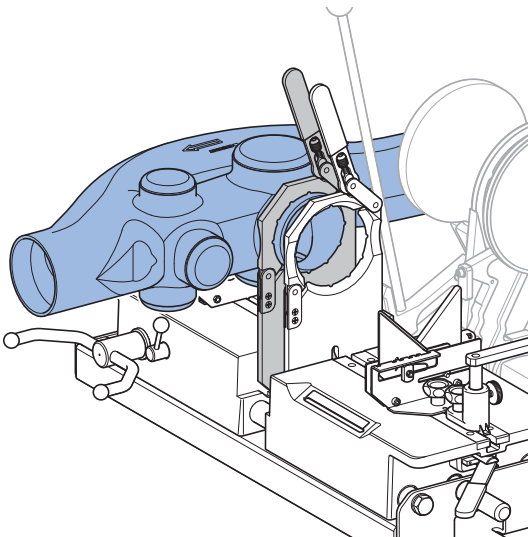

- 3** Clamp the corresponding pipe section of the branch discharge pipe.

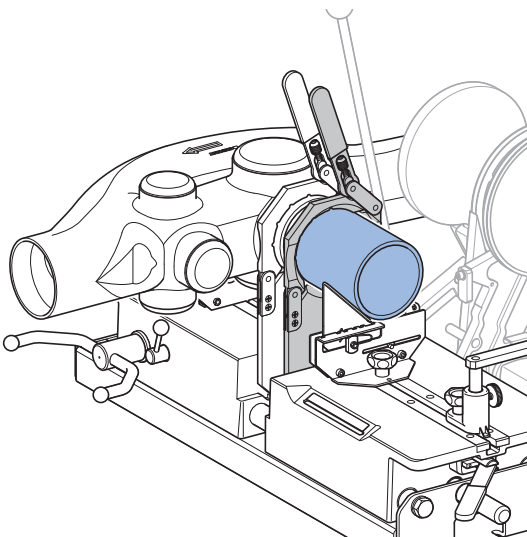

- 4** Surface plane the opened connection and the pipe section.

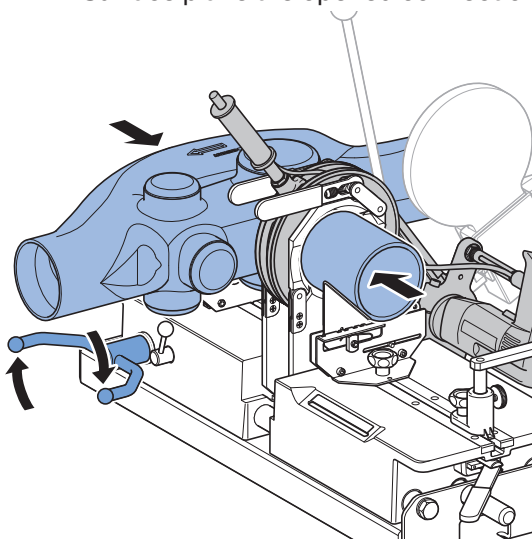

- 5** Heat both clamped parts.

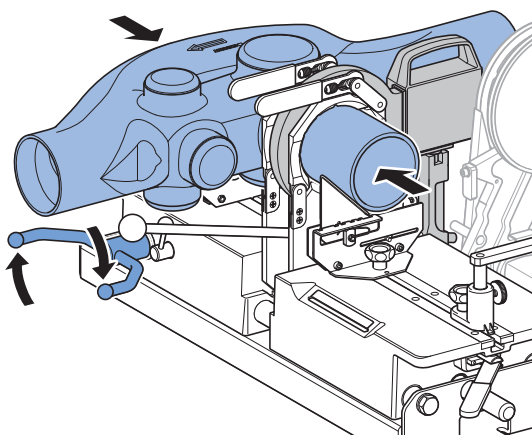

- 6** Press the parts together and let them cool.

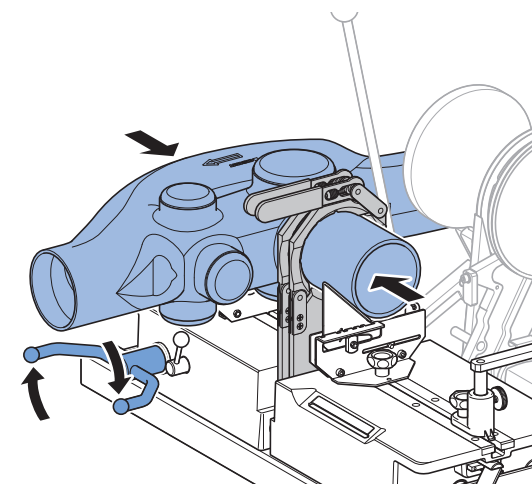

- 7** Remove fitting from welding machine.

Geberit Pty Ltd.

Unit 8a, 6-8 Byfield Street,
Macquarie Park, N.S.W. 2113 Australia

T +61 2 9889 7866 F +61 2 9889 7855

sales.au@geberit.com.au

www.geberit.com.au

