

## MODEL TAG/TFH TWIN FAN (TRI) WITH SINGLE PHASE TEM FAN

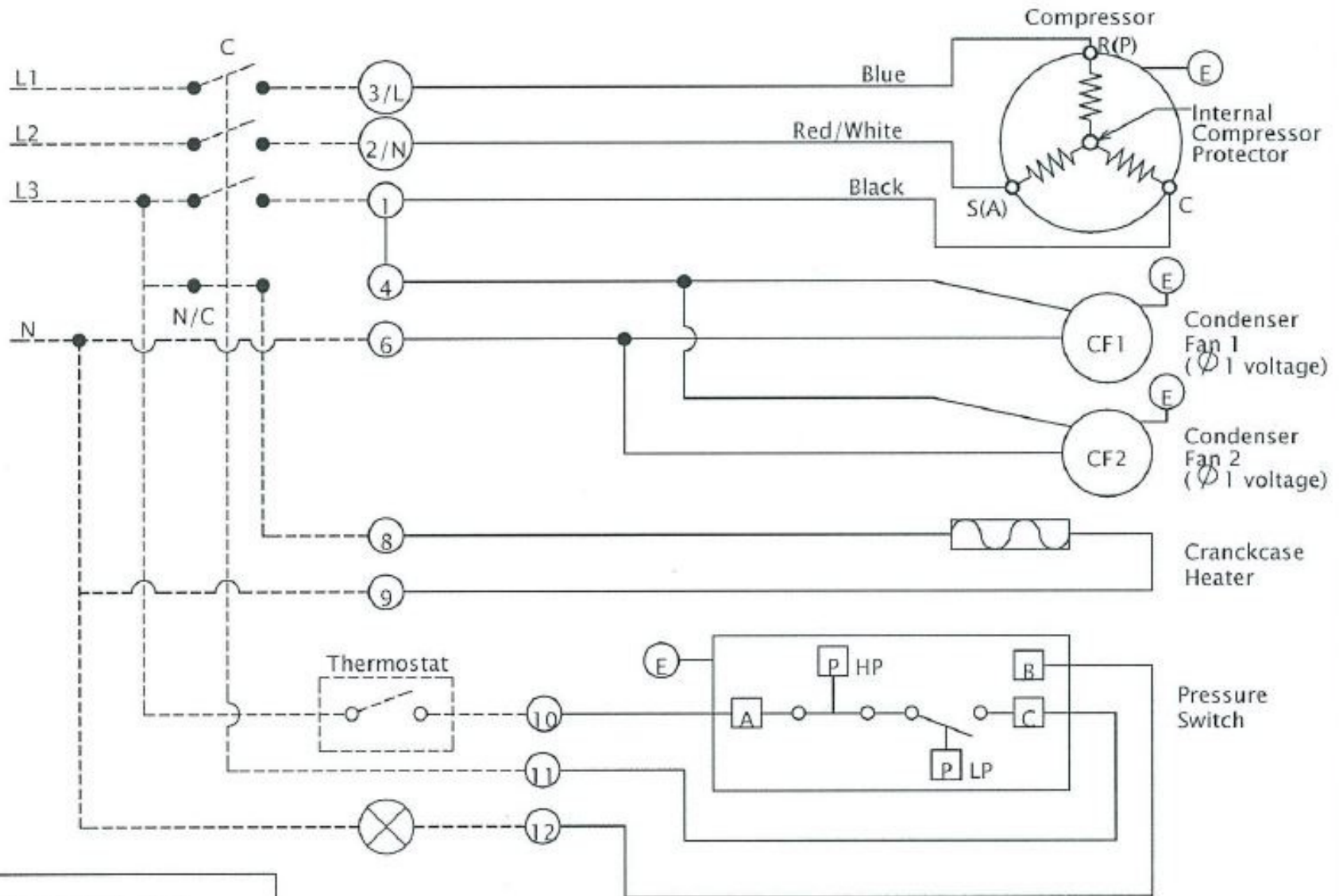

- - Terminal Number
- - Suggested Field Wiring
- C - Contactor
- ⊗ - Fault Lamp

Note :

Crankcase heater is self regulating so switching off during compressor operation is not mandatory. Condenser fan supply with single phase voltage.