

DURA EAGLE MINI BALL VALVE TESTED WATER

6mm – 15mm

SPECIFICATIONS

Recommended use	Water
Features	Quarter Turn Operation
Working Pressure	PN16 / 1600 kPa
Temperature Range	-10°C to +80°C
Warranty	12 Months
Standards	ATS 5200.012
Watermark	WMKA00683
Threads	Male: R Series Taper AS / ISO 7.1 Female: Rp Series AS / ISO 7.1

PHYSICAL SPECIFICATIONS

1	Body	DR Brass
2	Nut	DR Brass
3	Seal Ring	PTFE
4	Handle	Aluminium
5	Screw	Stainless Steel
6	Stem	DR Brass
7	O-Ring	NBR
8	Ball	DR Brass

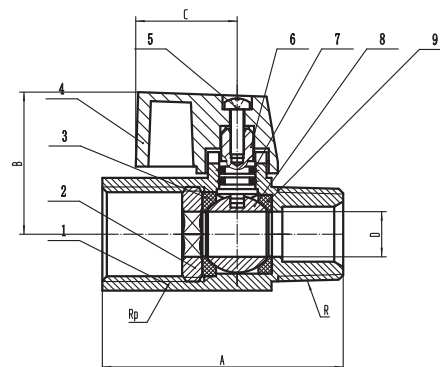
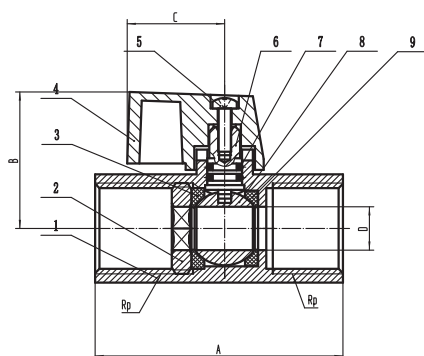

SPECIFICATIONS

Product Code	Product Description	Size	A	B	C	D
		DN	mm	mm	mm	mm
9502940	DURA EAGLE MINI BALL VALVE F&F TESTED 6MM	6	47	27.5	22.5	8
9502941	DURA EAGLE MINI BALL VALVE F&F TESTED 10MM	10	49.5	27.5	22.5	8
9502965	DURA EAGLE MINI BALL VALVE F&F TESTED 15MM	15	47.2	30.5	22.5	10
9503202	DURA EAGLE MINI BALL VALVE M&F TESTED 6MM	6	46	27.5	22.5	8
9503203	DURA EAGLE MINI BALL VALVE M&F TESTED 10MM	10	48	27.5	22.5	8
9503284	DURA EAGLE MINI BALL VALVE M&F TESTED 15MM	15	53.4	30.5	22.5	10