



Compressor
Voltage Code : FZ

AE4425Z-FZ1A

High Temp. Commercial (HP)

220 - 240V 1~ 50 Hz

R452A / R404A / R448A / R449A

AE4425Z-FZ1A_BF

Conditions	Frequency	Nominal Cooling Capacity		Sound Power ISO3745 / ISO 3743-1
		Watts	BTU/h	
EN12900 / R452A	50 Hz	546	1863	56 dBA
EN12900 / R404A	50 Hz	545	1858	56 dBA
EN12900 / R448A	50 Hz	547	1865	56 dBA
EN12900 / R449A	50 Hz	547	1865	56 dBA

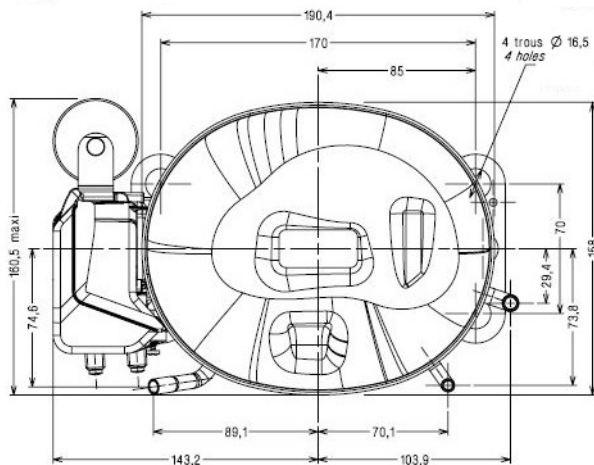
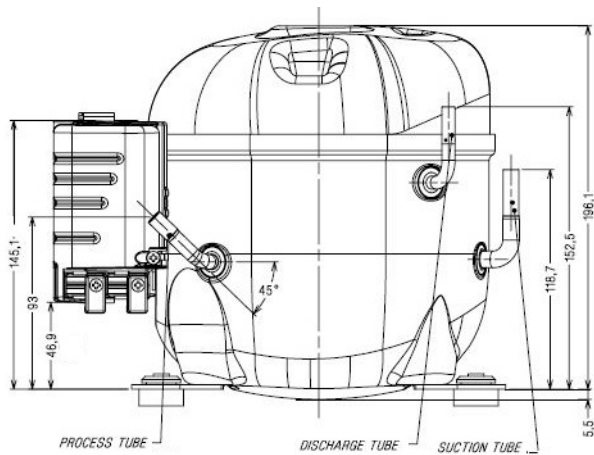

* EN12900 : T°Cond. 50.0°C / T°Evap. 5.0°C / T°Return gas temp.. 20.0°C
T°Subcooling. 0.0K

Certificates :



Displacement (cc)	4.2
Net Weight (Kg)	10.0
Oil Quantity (cc)	285.0
Oil Type	Polyolester
Expansion Device	Capillary_Tube/Expansion_Valve
Cooling	Fan
Main Winding (Ohm)	10.3
Start Winding (Ohm)	30.0
Current	
RLA (A)	1.8
LRA (A)	11
Electrical Equipment	CSIR
Overload	MRA58196
Time Check	6.5s - 16s / 7.4 A
Open Temp	120 °C
Close Temp	52°C
Start Capacitor	64 µF / 250 V
Current Relay	RP42**
Pick Up	5.8A
Drop Out	4.95A
Refrigerating connection for OD	
Suction Tube	6.35 (1/4")
Discharge Tube	4.76 (3/16")
Process Tube	6.35 (1/4")

Note : Tecumseh reserves the right to change information contained in this document without notification.



Tecumseh

AE4425Z-FZ1A	Tension FZ : 220 - 240V 1~ 50 Hz
---------------------	---

Les performances sont données dans les conditions EN12900 :	Gaz aspirés :	20.0 °C
Condition Dew	Sous refroidissement :	0.0 K
The performance data are in EN12900 conditions :	Return gas :	20.0 °C
Dew Condition	Subcooling :	0.0 K

50 Hz R452A											
											N°3031
4 T condensation	5 T évaporation	(°C)	-25	-20	-15	-10	-5	0	5	10	15
30	1 P frigorifique	(Watt)	195	256	330	420	528	655	804	975	1172
	2 P absorbée	(W)	151	165	177	187	194	199	200	198	193
	3 I absorbée	(A)	1.37	1.40	1.43	1.46	1.48	1.49	1.50	1.51	1.51
40	1 P frigorifique	(Watt)		211	275	351	442	550	675	821	989
	2 P absorbée	(W)		172	189	203	216	226	234	238	239
	3 I absorbée	(A)		1.40	1.45	1.49	1.53	1.56	1.59	1.62	1.64
50	1 P frigorifique	(Watt)			220	282	356	444	546	666	805
	2 P absorbée	(W)			198	218	236	252	265	276	284
	3 I absorbée	(A)			1.46	1.53	1.59	1.64	1.69	1.73	1.77
60	1 P frigorifique	(Watt)				214	271	338	417	510	619
	2 P absorbée	(W)				231	254	276	295	313	327
	3 I absorbée	(A)				1.56	1.64	1.72	1.79	1.85	1.91

50 Hz R404A											
											N°3033
4 T condensation	5 T évaporation	(°C)	-25	-20	-15	-10	-5	0	5	10	15
30	1 P frigorifique	(Watt)	208	270	345	436	543	670	817	987	1181
	2 P absorbée	(W)	160	174	186	196	203	207	208	205	198
	3 I absorbée	(A)	1.45	1.48	1.50	1.53	1.54	1.55	1.56	1.56	1.55
40	1 P frigorifique	(Watt)	168	222	286	362	452	558	681	823	987
	2 P absorbée	(W)	164	182	199	213	226	235	242	246	245
	3 I absorbée	(A)	1.43	1.48	1.53	1.56	1.60	1.63	1.65	1.67	1.68
50	1 P frigorifique	(Watt)		175	228	290	362	446	545	659	792
	2 P absorbée	(W)		189	210	229	247	262	274	284	291
	3 I absorbée	(A)		1.48	1.55	1.61	1.66	1.71	1.75	1.79	1.82
60	1 P frigorifique	(Watt)			171	218	272	335	409	496	597
	2 P absorbée	(W)			220	244	267	288	306	322	335
	3 I absorbée	(A)			1.57	1.65	1.72	1.79	1.85	1.91	1.96



1 = cooling capacity 2 = power input 3 = current 4 = condensing temperature 5 = evaporating temperature

Nota : Tecumseh se réserve le droit de modifier les informations contenues dans ce document sans préavis.
Note : Tecumseh reserves the right to change information contained in this document without notification.

© 2020 Tecumseh Products Company
All rights reserved



Tecumseh

AE4425Z-FZ1A	Tension FZ : 220 - 240V 1~ 50 Hz
---------------------	---

Les performances sont données dans les conditions EN12900 :	Gaz aspirés :	20.0 °C
Condition Dew	Sous refroidissement :	0.0 K
The performance data are in EN12900 conditions :	Return gas :	20.0 °C
Dew Condition	Subcooling :	0.0 K

50 Hz R448A (*)											
											N°3032
4 T condensation	5 T évaporation	(°C)	-25	-20	-15	-10	-5	0	5	10	15
30	1 P frigorifique	(Watt)	172	231	304	392	499	625	774	947	1147
	2 P absorbée	(W)	141	153	165	175	182	187	189	187	181
	3 I absorbée	(A)	1.27	1.30	1.33	1.36	1.38	1.40	1.41	1.42	1.42
40	1 P frigorifique	(Watt)		191	255	331	422	531	660	810	984
	2 P absorbée	(W)		161	177	191	203	213	220	225	225
	3 I absorbée	(A)		1.31	1.36	1.40	1.44	1.47	1.50	1.53	1.54
50	1 P frigorifique	(Watt)			207	271	348	439	547	674	822
	2 P absorbée	(W)			187	206	223	239	252	263	270
	3 I absorbée	(A)			1.38	1.44	1.50	1.56	1.61	1.65	1.69
60	1 P frigorifique	(Watt)				214	276	349	437	541	663
	2 P absorbée	(W)				220	243	265	284	302	316
	3 I absorbée	(A)				1.48	1.57	1.65	1.72	1.79	1.85

50 Hz R449A (*)											
											N°3034
4 T condensation	5 T évaporation	(°C)	-25	-20	-15	-10	-5	0	5	10	15
30	1 P frigorifique	(Watt)	172	231	304	392	499	625	774	947	1147
	2 P absorbée	(W)	141	153	165	175	182	187	189	187	181
	3 I absorbée	(A)	1.27	1.30	1.33	1.36	1.38	1.40	1.41	1.42	1.42
40	1 P frigorifique	(Watt)		191	255	331	422	531	660	810	984
	2 P absorbée	(W)		161	177	191	203	213	220	225	225
	3 I absorbée	(A)		1.31	1.36	1.40	1.44	1.47	1.50	1.53	1.54
50	1 P frigorifique	(Watt)			207	271	348	439	547	674	822
	2 P absorbée	(W)			187	206	223	239	252	263	270
	3 I absorbée	(A)			1.38	1.44	1.50	1.56	1.61	1.65	1.69
60	1 P frigorifique	(Watt)				214	276	349	437	541	663
	2 P absorbée	(W)				220	243	265	284	302	316
	3 I absorbée	(A)				1.48	1.57	1.65	1.72	1.79	1.85

1 = cooling capacity 2 = power input 3 = current 4 = condensing temperature 5 = evaporating temperature

(*) Veuillez vous référer strictement aux Recommandations d'Utilisation et Bulletins Marketing Tecumseh du fait de la température de reflux élevée pour les applications LBP.
 (*) Due to very high discharge temperature especially on LBP conditions, please strictly refer to Tecumseh Guidelines & Marketing Bulletin when using this refrigerant.

Nota : Tecumseh se réserve le droit de modifier les informations contenues dans ce document sans préavis.

Note : Tecumseh reserves the right to change information contained in this document without notification.

© 2020 Tecumseh Products Company
All rights reserved