

XE70 SERIES

T6376/T6377

THERMOSTATS HEATPUMPS & SMALL AIR CONDITIONERS

PRODUCT SPECIFICATION SHEET

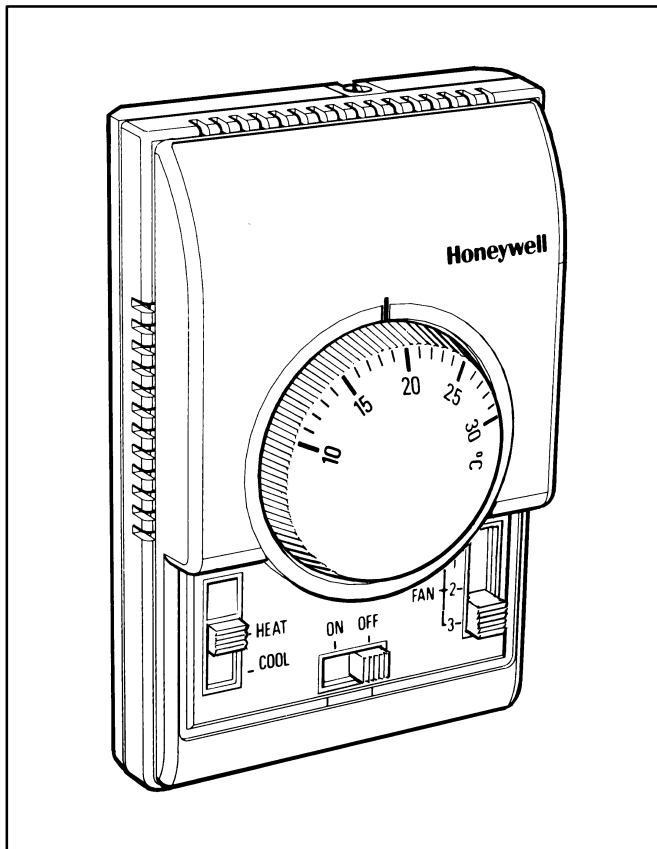

The T6376 and T6377 are designed to control the valves, the fan and the compressor in split units, heatpumps and small air conditioners.

The thermostat operates the compressor to provide either heating or cooling (as selected by the system switch) at the desired setpoint temperature.

The fan can also be controlled from the thermostat. In some cases it is wired to run continuously, and can be switched off with the system ON/OFF switch, while with other models there is a switch which gives the choice of running the fan continuously, or cycling it with the thermostat.

Versions are available with a manual 3-SPEED FAN switch, and with a system ON/OFF switch, or a HEAT/OFF/COOL switch

Heat/cool changeover operation can be accomplished either by a manually operated HEAT/FAN/ COOL switch or a HEAT/OFF/ COOL switch on the front of the thermostat.

FEATURES

- Dual diaphragm sensing element ensures close temperature control for all loads and applications
- Attractive modern styling makes this thermostat ideal for locating in the occupied space, particularly in offices or hotels
- Versions with heat anticipator, which improves temperature control in both heating and cooling operation
- Thermostat mounts directly onto a wall or conduit box
- Slide switches allow manual control of system operation and fan speed
- Optional extras:
 - rangestops F42006646-001
 - tamperproof cover F42008489-001 (opaque), F42008489-002 (transparent)

SPECIFICATIONS

Model	Switches							Features	
	ON/OFF (SPST)	3-speed Fan (SPTT)	Fan/ Auto/Cont (SPDT)	Heat/Cool (SPDT)	Heat/Cool (DPDT)	Heat/Off/ Cool (DPTT)	Heat/Fan/ Cool (DPTT)	Fixed Deadband	Auto Change- over (Aquistat)
T6376B1004			✓			✓			
T6377B1003	✓	✓					✓		
T6377B1011		✓	✓			✓			
T6377B1045		✓	✓			✓			

Setpoint range : 10...30°C. By means of a large setpoint dial

Supply voltage : 230 V~, 50...60 Hz

Thermostat switch : S.P.D.T.

Performance : Typical differential 1°C (heating & cooling) at 20°C at 50% load with anticipator connected

Electrical ratings : 4(2) A, 230 V~
Typical loads are fans, zone valves, relays, compressors. Compressors of greater than 0.5 kW capacity should be switched via a contactor.

Operational life : Greater than 100,000 cycles (all loads) for thermostat contacts at 230 V~
Greater than 6,000 operations for all manually operated switches

Mounting : Mounts directly onto wall or wall-box (mounting screws supplied)

Wiring : Up to 9 screw-in terminals per unit, capable of accepting wires up to 1.5 mm²

Enclosure : Plastic 2-piece housing

Dimensions : 85 x 130 x 40 mm (w x h x d)

Protection class : IP30

Environmental requirements : Operating temperature range 0 to 40°C
Shipping and storage temperature range -20 to 50°C
Humidity range 0 to 90% rh, non-condensing

Approvals : CE mark, complying with standards EN60730-1 (1995), EN55014-1 (1997), EN55014-2 (1996).
Product must be wired as shown for CE

DIMENSIONS

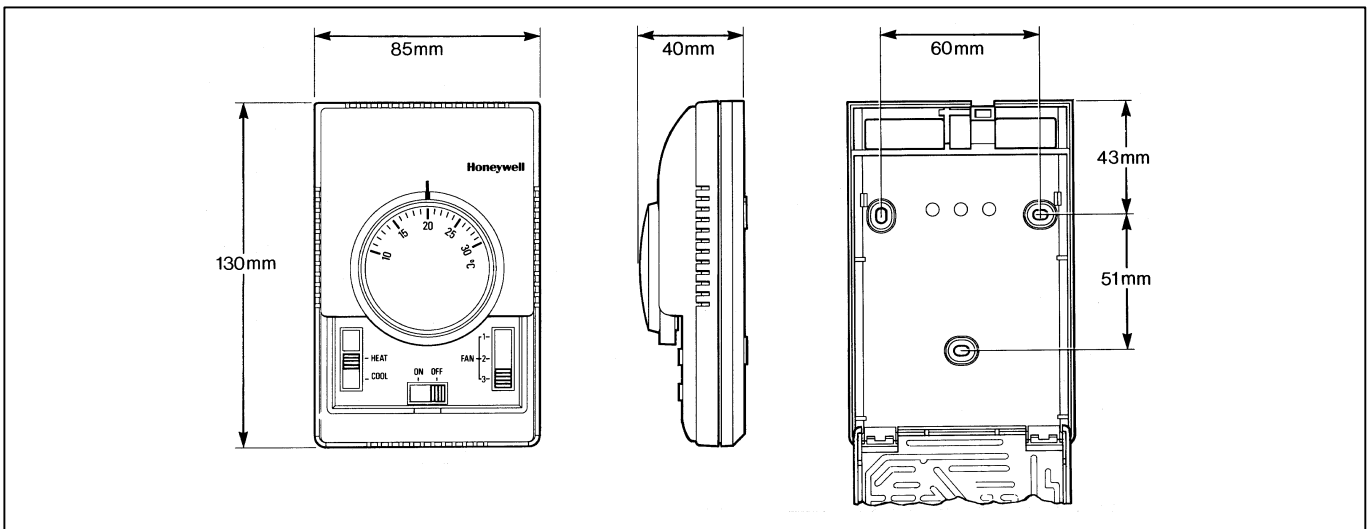

INSTALLATION

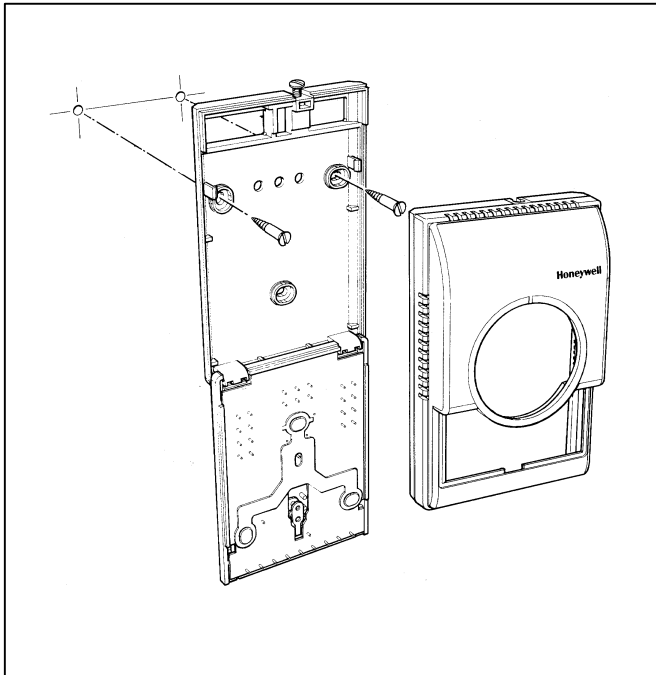

Location

The XE70 Series thermostat is the temperature control element in the fan-coil or air-conditioning system, and must be located in a position with good air circulation, on an inside wall about 1.5 m above the floor to sense the average temperature. Do not position the thermostat in draughts, near hot or cold air sources or where it will be affected by radiant heat from the sun or other appliances.

Mounting the thermostat

Any XE70 Series thermostat can be directly mounted on the wall or on a conduit box (see diagram). Mounting screws are supplied for both alternatives.

Wiring the thermostat

The standard wiring access is via a hole in the base of the thermostat, near the top edge.

IMPORTANT

1. The installer must be a trained service engineer
2. Disconnect the power supply before beginning installation

OPERATION

Sensing element

The thermostat sensing element comprises two circular, flexible metal plates welded together at the rims and encapsulating a gas/liquid combination whose pressure changes in response to variations in temperature. This dual-diaphragm expands and contracts with ambient temperature changes to operate a snap-acting switch which controls the heating or cooling circuit.

Heat anticipator

It is recommended that the heat anticipator is always connected for both heating and cooling operation.

Switches

All switches are slide switches for ease of operation.

The ON/OFF switch is a system on/off switch, as it removes power from the thermostat.

The FAN SPEED switch allows selection of 3 different fan speeds, 1 (low), 2 (medium), and 3 (high).

The FAN AUTO/CONT switch allows The choice of 2 different operating modes for the fan - either continuously (cont), or cycled by the thermostat (auto)

The DPTT HEAT/OFF/COOL and HEAT/FAN/COOL switches allow selection of either heating or cooling operation, but also have an additional selection position which disables all the outputs except that of the fan. In both these cases the fan can be controlled separately, either by the system ON/OFF switch or by the FAN AUTO/CONT

APPLICATION

		T6376B 1004	T6377B 1003	T6377B 1011	T6377B 1045
Application	Ventilation				
	2-pipe fan-coil				
	4-pipe fan-coil				
	Heatpump	*	*	*	
	Air-conditioner	*			*
Control Capability	Heat or Cool				
	Heat/cool	*	*	*	*
	Changeover (auto or manual)	manual	manual	manual	manual
	Fan control (auto or cont)	either	cont	either	either
	Fan speed control		*	*	*
	Valve control	*	*	*	*
	Compressor control	*	*	*	*

WIRING

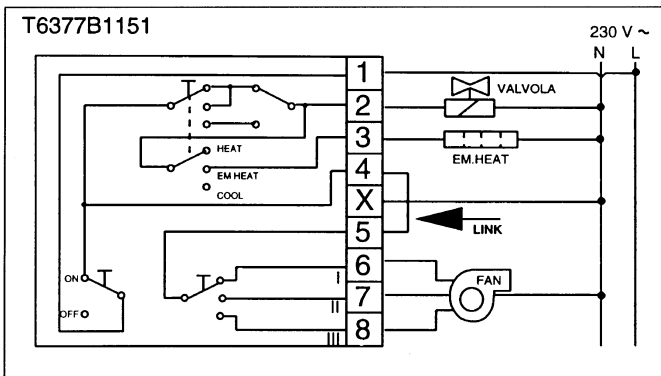
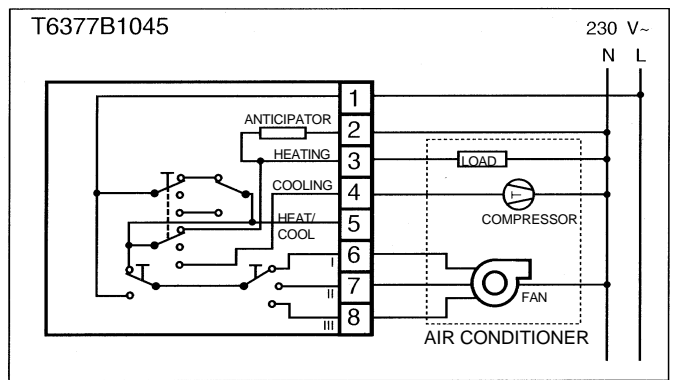
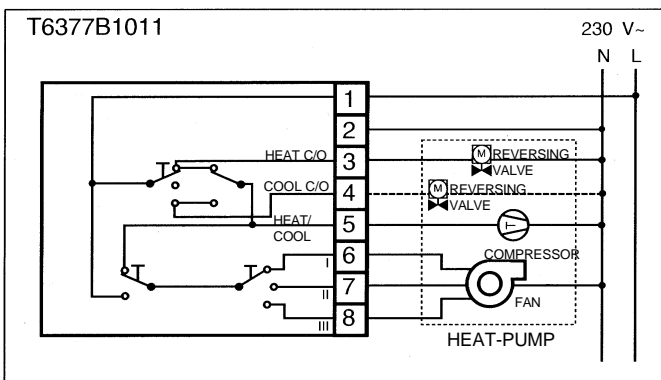
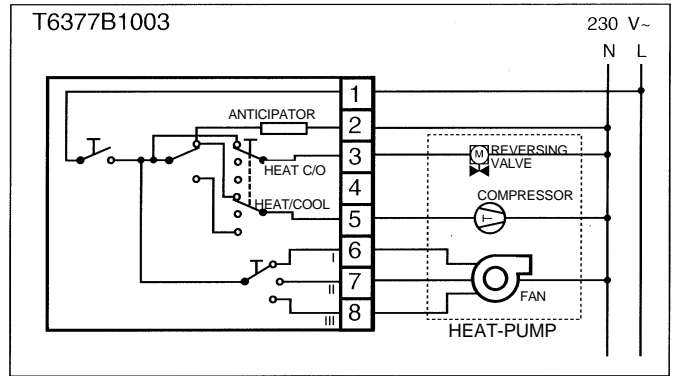
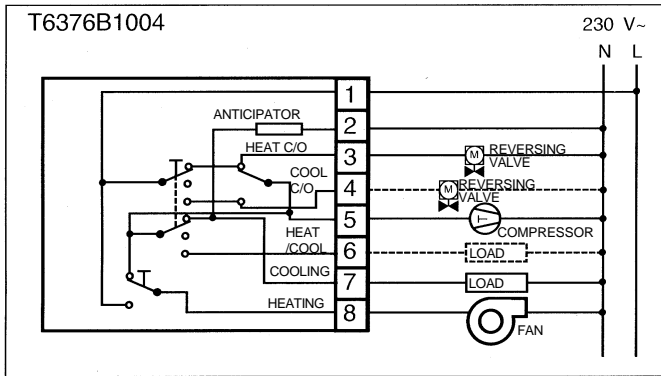

Honeywell

Honeywell Control Systems Limited
 Newhouse Industrial Estate
 Motherwell ML1 5SB
 United Kingdom

<http://europe.hbc.honeywell.com>