



Milli Pure Progressive Wall Basin Mixer System 250mm with Cirque Textured Handle (3*)

SPECIFICATIONS

Recommended Use	Domestic, Commercial, Hotel
Colour Variations	Chrome, Matte Black, Brushed Nickel, Brushed Gunmetal
Recommended Pressure Range	300 - 500Kpa
Max Continuous Working Pressure	500Kpa
Max Continuous Working Temperature	65 deg. C
Suitable for Storage Tank Hot Water	Yes
Suitable for Continuous Flow Hot Water	Yes
Suitable for Gravity Feed Hot Water	No

WARRANTY

Warranty - Domestic Use	15 Years
Spare Parts	1 Year
Labour	1 Year

Please refer to Warranty Page for full Terms and Conditions

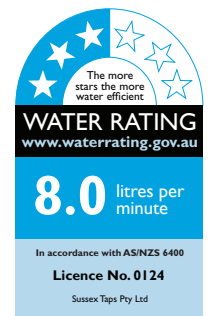
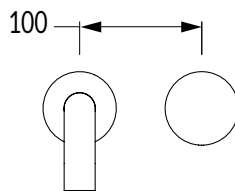
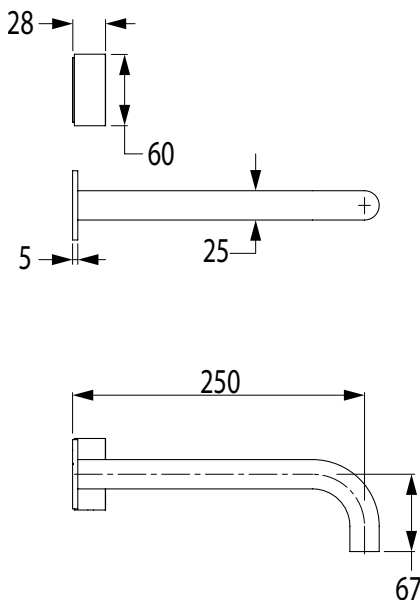

AS/NZS 3718
LIC. 20081



Dimensions are nominal measurements only.

Disclaimer: Products in this specification manual must by regulation be installed by licensed and registered trade people. The manufacturer/distributor reserves the right to vary specifications or delete models from their range without prior notification. Dimensions are nominal measurements only. Dimensions and set-outs listed are correct at time of publication however the manufacturer/distributor takes no responsibility for printing errors.

Published 01/02/2019

To see the complete Milli range go to
www.reece.com.au/bathrooms