

LAUFEN

PALOMBA

COUNTER BASIN 900

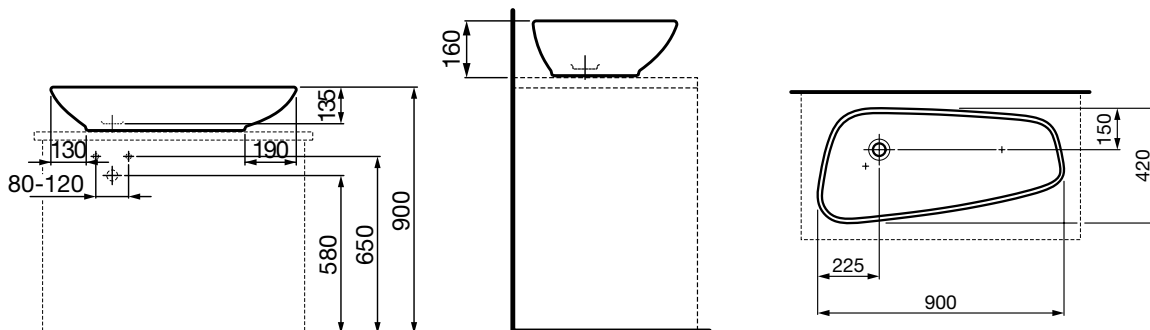

Set out may differ based on trap used.

SPECIFICATION

Fixing requirements	Refer to diagram
Integral overflow	No
Tap hole availability	No taphole
Plug & waste	Suits 32 x 40mm non-overflow waste
Water storage	17 litres
Colour availability	White

FEATURES

Recommended use	Domestic, hotel or commercial
Weight	16.5kg
Finish	LAUFEN Clean Coat



To see the complete LAUFEN range go to www.reece.com.au/bathrooms

CLEANING RECOMMENDATIONS

Soapy water or approved bathroom cleaners. This bathroom product should not be cleaned with abrasive materials. Damage caused by any improper treatment is not covered by the product warranty. Refer to Warranty Conditions.

Disclaimer: Products in this specification manual must by regulation be installed by licensed and registered trade people. The manufacturer/distributor reserves the right to vary specifications or delete models from their range without prior notification. Dimensions and set-outs listed are correct at time of publication however the manufacturer/distributor takes no responsibility for printing errors.

Tech Page Version 1

LAUFEN
Bathroom Culture since 1892 www.laufen.com

reece