



WELS Reg #U00442



Scan QR code to view online



Image shows Recessed Sanistep Urinal.

Floor Mounted Model is supplied with a kick plate.

features and benefits

- WELS and WaterMark certified
- Recessed or floor mounted models
- Vandal resistant design
- Manufactured to custom lengths
- Compatible with BRITEX Sensor Flush Systems
- Hinged grate for ease of cleaning
- Water saver sparge system
- Available in 'L' or 'U' shaped configurations

about

The *BRITEX Sanistep Urinal* is the most frequently specified stainless steel urinal in Australia and can be found in many of Australia's iconic sports and entertainment stadiums. Manufactured from durable 1.2mm grade 304 stainless steel, Sanistep urinals are hand fabricated and fully welded with sturdy reinforcement to the rear, providing a sound structural finish. Sanistep urinals incorporate a hinged floor grate to allow for ease of cleaning and feature our unique weir style sparge, which enables the water to flush in an even flow with minimum water and maximum efficiency. WaterMark and WELS certified as required by plumbing regulations and government legislation.

sample spec. text

BRITEX S.S. Recessed/Floor Mounted Sanistep Urinal - XXXXmm Long. WELS rating and WaterMark Level 1 certified. Complete with hinged floor grate and BRITEX Smart SaniFlush Sensor System - Product Code USAN

*RED TEXT may denote a **variable** where one option only is to be selected, a **nominal dimension** that needs to be specified, or an **optional feature** that can be removed if not required. Please refer to the back of this page for additional specification details and options.

VISIT BRITEX.COM.AU TO DOWNLOAD BIM FILES, CAD DRAWINGS AND THE MOST CURRENT PRODUCT LITERATURE.



MELBOURNE
Britex Place, Mirra Crt
Bundoora VIC 3083
t (03) 9466 9000
e vic@britex.com.au

SYDNEY
16 Northumberland Drv
Taren Point NSW 2229
t (02) 9531 2100
e nsw@britex.com.au

PERTH
Unit 1/8 Principal Link
Malaga WA 6090
t (08) 9249 5464
e wa@britex.com.au

BRISBANE
19 Manilla St
East Brisbane QLD 4169
t (07) 3363 2400
e qld@britex.com.au

ADELAIDE
The Britex Group
SA State Office
t 1300 764 744
e sa@britex.com.au

SANISTEP URINAL

PRODUCT CODE

USAN

HOW TO SPECIFY: Sanistep Urinal

Sample Specification Code

A **B** **C** **D** **E** **F**
USAN - 1500 - RE - R - 100 - R

= Sanistep Urinal, 1500mm Long, Recessed, Rear Entry, 100mm Right Hand Waste

Specification Key

| | |
|-------------------------------|----------------------------------|
| A = Product Code | E = Waste Outlet Size |
| B = Urinal Length (mm) | 100 : 100mm |
| C = Mounting Options | 75 : 75mm |
| FM : Floor Mounted | 50 : 50mm |
| RE : Recessed | F = Waste Outlet Position |
| D = Entry Point | L : Left Hand Waste |
| T : Top Entry | R : Right Hand Waste |
| R : Rear Entry | C : Centre Waste |

Water Inlets for Urinals:

One water inlet is required for every 2000mm of Urinal, or part thereof.

- e.g. 600mm - 2000mm = 1 inlet
 2001mm - 4000mm = 2 inlets
 4001mm - 6000mm = 3 inlets

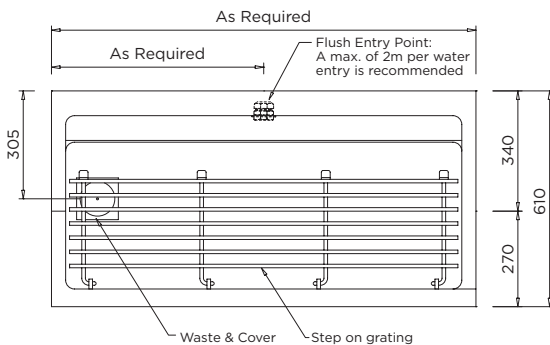

MODEL USAN Plan

When specifying this product please include:

- Product **Name** and **Code**
- Product **Length**
- **Recessed** or **Floor Mounted**
- Top or rear **Water Entry**
- Size and position of **Outlet**

specifying guide

options

- 'L' and 'U' shaped configuration
- Smart SaniFlush Sensor System: pg 3.01
- Outlet size: 100mm, 75mm, 50mm or custom
- Outlet position (left/right end preferred)
- Inlet size - 38mm or 25mm
- Free standing ends (if not between walls)
- Type 316 S.S. (Export models)
- Joining strip for joining modular lengths

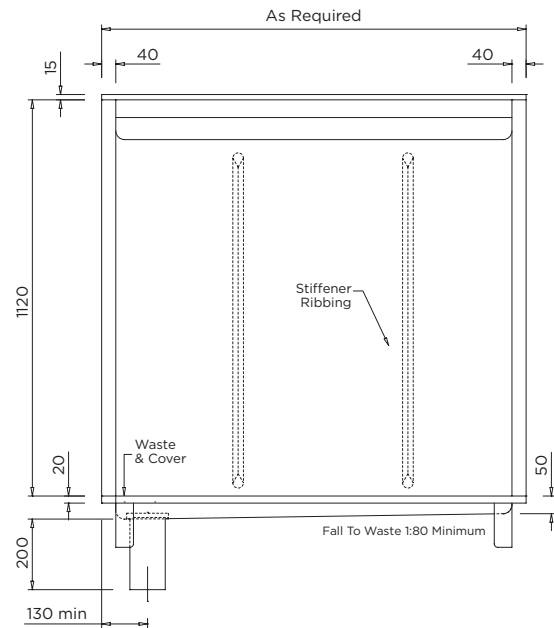

MODEL USAN Front Elevation

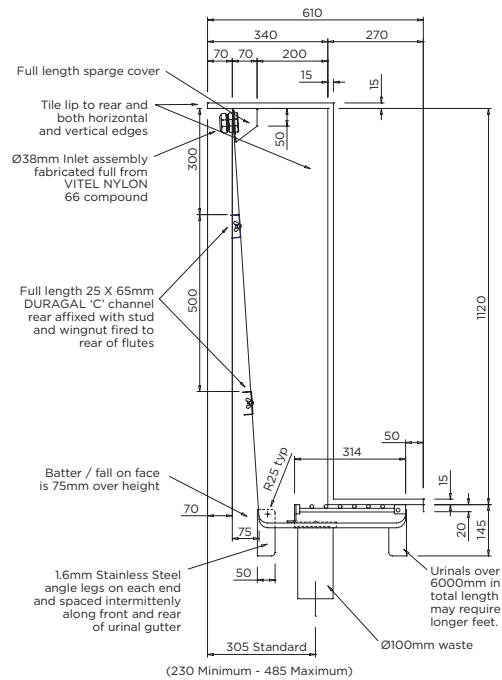

Recommended floor cut out for recessed model is 650W x 160D x Urinal Length

MODEL USAN Typical Section (Recessed Model)

VISIT BRITEX.COM.AU TO DOWNLOAD BIM FILES, CAD DRAWINGS AND THE MOST CURRENT PRODUCT LITERATURE.



britex.com.au | info@britex.com.au | A.B.N 83 004 309 737

Due to ongoing research and our commitment to product development, details are subject to change without notice. Details accurate at time of print.

Please refer to britex.com.au for the most current product information. Allow +/- 5mm tolerance for dimensions and setouts shown in product literature.



Quality ISO 9001