

Milli Etch Wall Basin/Bath Hostess Tap System

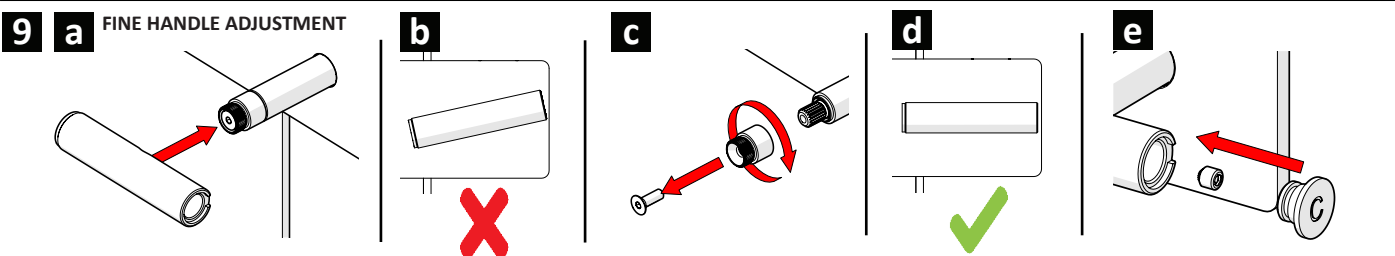
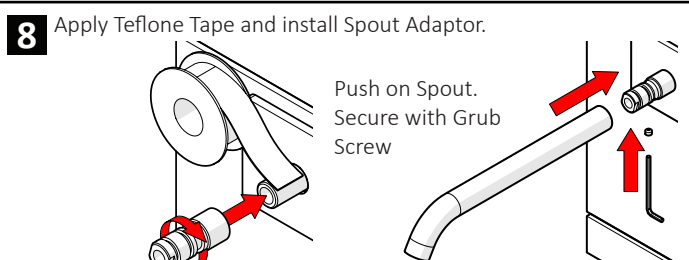
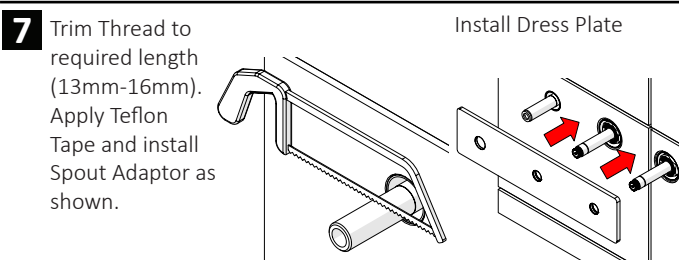
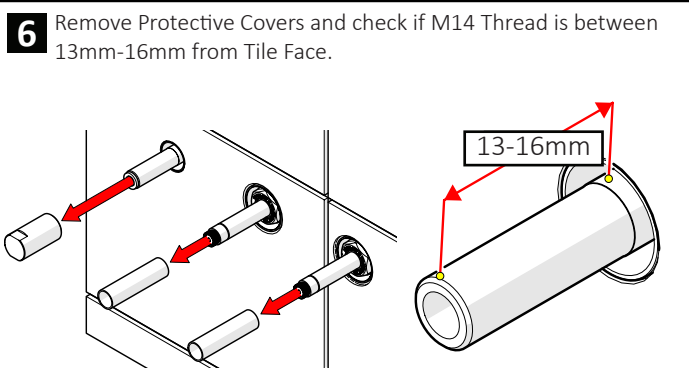
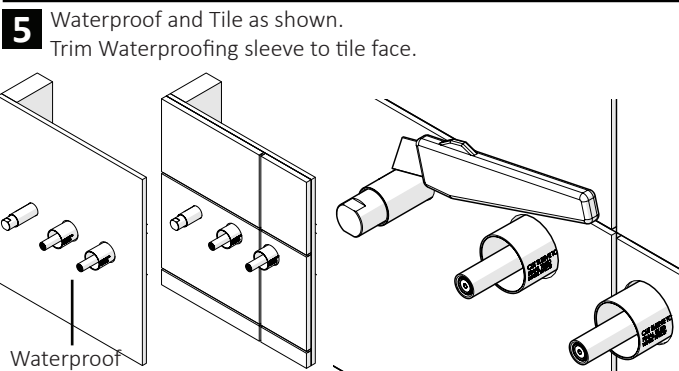
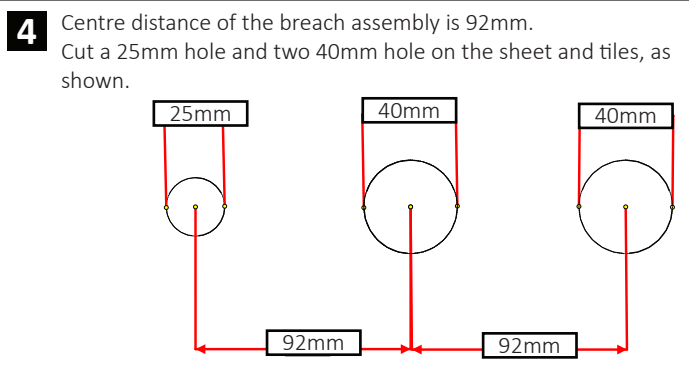
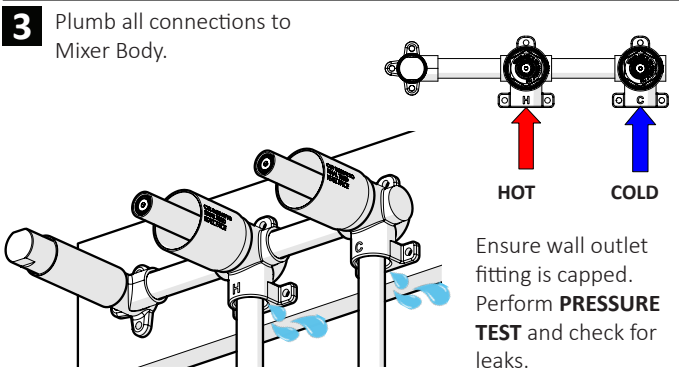
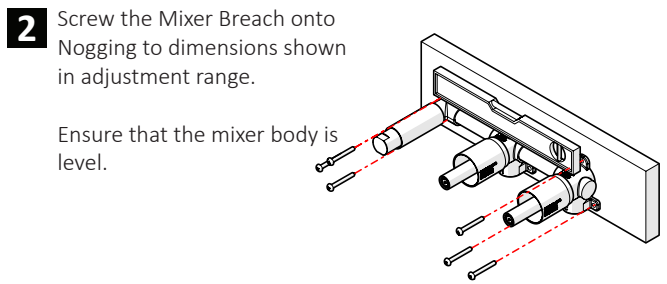
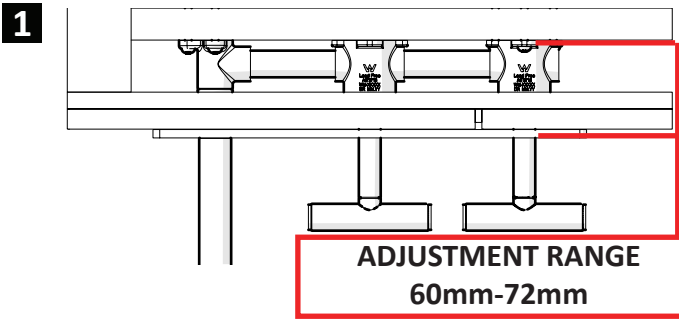

Care Details

We recommend the use of soapy water or approved cleaners. This product should not be cleaned with abrasive materials. Damage caused by any improper treatment is not covered by the product warranty. Refer to Warranty Conditions

Installation should comply with Australian standard AS3500.1 or relevant local authority requirements. Showers may not be suitable for use within:

- Gravity-fed water systems
- Some instantaneous hot water systems

Any flow controller incorporated in the outlet to be tightened to prevent removal by hand. As Per AS3718

Plumbers, please ensure a copy of the installation instruction is left with the end user for future reference.

