

*Armitage
Shanks*

Avon 21 Self-closing taps (Push button)

INSTALLATION INSTRUCTIONS

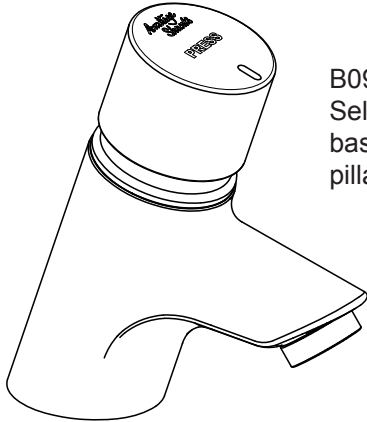

B0992AA
Self-closing
basin
pillar tap



WaterMark
AS/NZS 3718 WMK 25822
SAI Global

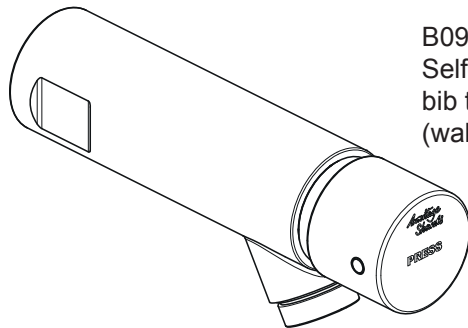

B0990AA & B1055AA
Self-closing
bib tap
(wall mount)

IMPORTANT
BEFORE CONNECTION, FLUSH WATER THROUGH PIPEWORK TO REMOVE
ALL DEBRIS ETC. WHICH COULD DAMAGE THE VALVE MECHANISM

INSTALLER: After installation please pass this instruction booklet to user

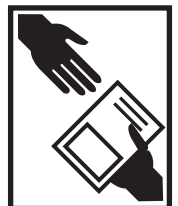

TABLE OF CONTENT

1	PRODUCT BOX CONTENTS	3
2	DIMENSIONS	4
3	WATER SUPPLY CONDITIONS	5
4	NATIONAL PLUMBING & DRAINAGE CODE	5
	4.1 WATER SUPPLY CONTROLLING DEVICES (EXTERNAL).....	5
5	INSTALLATION GUIDE	6
	5.1 B0992AA.....	6
	5.2 B0990AA & B1055AA	7
6	TAP OPERATION.....	8
7	OUTLET DETAILS	8
8	RUN TIME ADJUSTMENT	9
9	MAINTANANCE (CLEARING PILOT HOLE)	10
10	CARTRIDGE REPLACEMENT	11
11	SPARE PARTS.....	12
	11.1 B09992AA.....	12
	11.2 B0990AA & B1055AA	13
12	CLEANING CHROME SURFACES	14
13	AVON 21 PRODUCTS	15



Avon 21 Self-closing taps

These Avon 21 products are self-closing taps designed for water economy. These products are fitted with simple press down handles for easy actuation. The run-time until automatic shut off is adjustable.

These products are fitted with anti-vandal outlets.

These products are designed to be supplied with either premixed warm or cold water.

B0992AA Basin pillar tap

B0990AA Wall mounted bib tap

B1055AA Wall mounted bib tap with handle marked "warm"

1 PRODUCT BOX CONTENTS

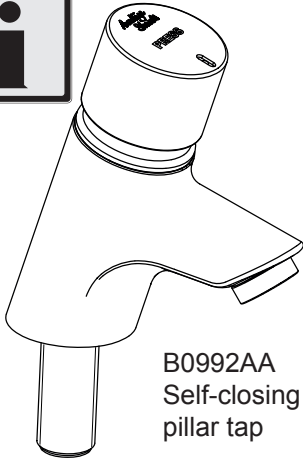

B0992AA
Self-closing
pillar tap

Index pin set:
red, yellow &
blue



Basin seal
moulding

G1/2" Back-nut

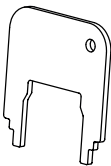

Run time
adjustment key

Index pin set: red, yellow
& blue

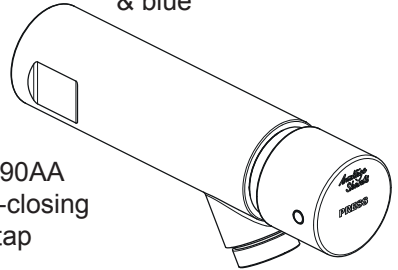

B0990AA
Self-closing
bib tap

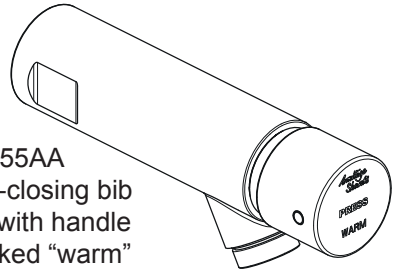

B1055AA
Self-closing bib
tap with handle
marked "warm"

ALL PRODUCTS

Shown above are supplied with
these tools:



Outlet key

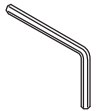

1x 2.5mm
hexagonal key

Note for B0992AA: Installer should fit the most suitable colour of index pin into the handle of the basin pillar tap. Blue for cold water & either red or yellow for warm water.

2 DIMENSIONS

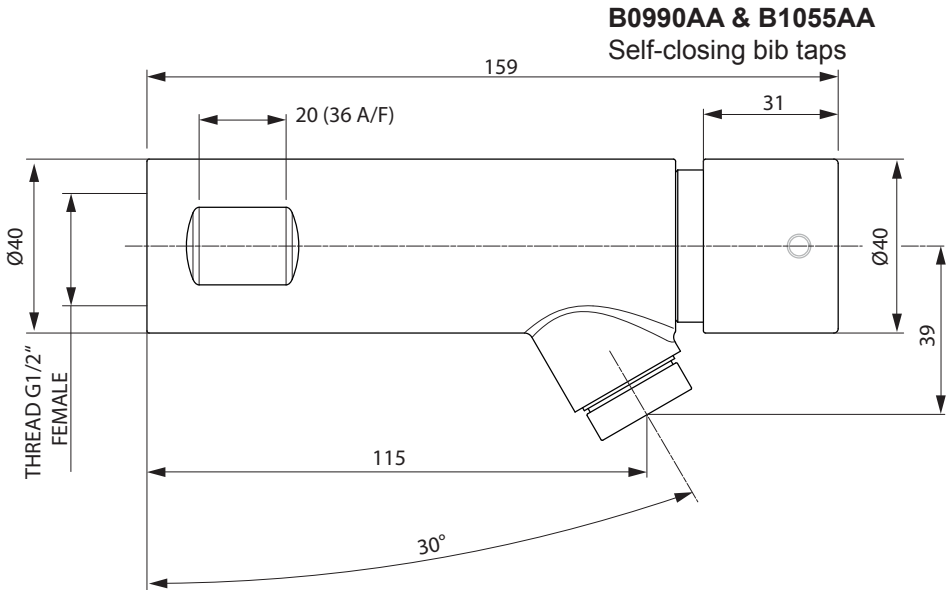
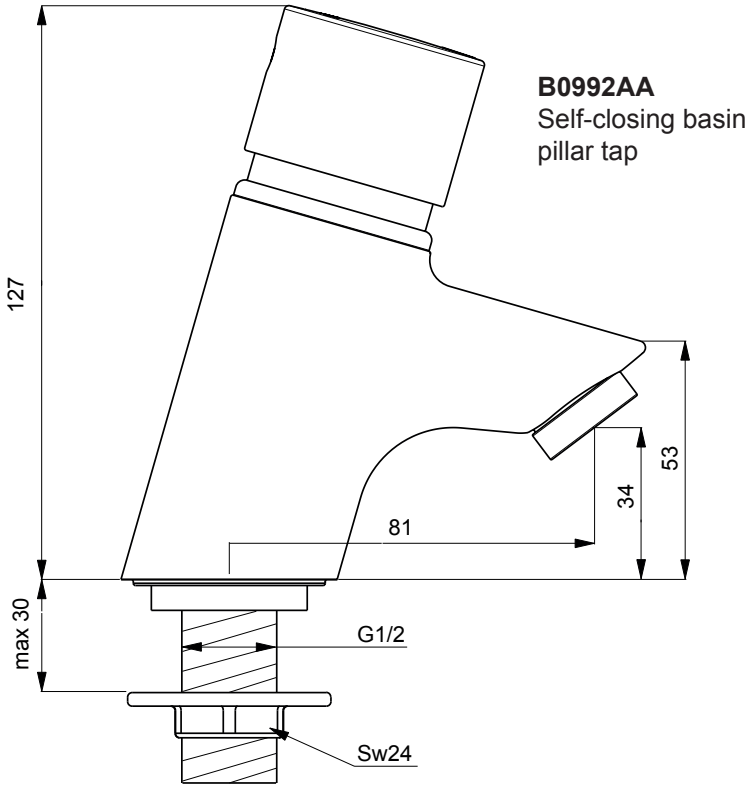

3 WATER SUPPLY CONDITIONS

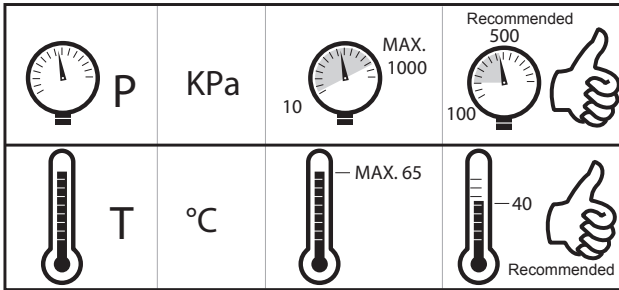

These products are designed to be supplied with either premixed warm or cold water.

Avoid supplying scalding water to the HOT tap. Hot water temperature supply should be controlled to circa 40°C.

In order to maintain water quality, the hot supply should be stored & distributed at a temperature greater than 55°C.

Use of an appropriate temperature reduction device (i.e. tee pattern thermostat) is recommended to ensure delivery of safe hot water temperatures from the hot tap

Supply pressures:

The recommended working pressure for self-closing taps is 100 to 500 KPa.

Exceeding this pressure will adversely affect the operation of the taps.

This adverse effect can be overcome by using PRV to reduce the pressure accordingly.

4 NATIONAL PLUMBING & DRAINAGE CODE

The products covered by this installation and maintenance instruction must be installed in accordance with the provisions of AS/NZS 3500 & any relevant local regulations. Installations not complying with AS/NZS 3500 may void the product performance & warranty. Armitage Shanks strongly recommends that this product is fitted by a professional installer.

4.1 Water supply controlling devices (external)

Pressure & temperature ranges of the incoming water supplies should comply with the limits specified above.

NOTE: Maximum recommended static pressure in AS 3500.1.2 is 500 Kpa.

To avoid exceeding this pressure, install a suitable pressure reducing valve - PRV (or pressure limiting valve - PLV) on both hot & cold incoming water supply systems. A suitable location for a PRV on the hot supply may be on the cold inlet to the heating appliance.

Similarly, if the water supply temperature ranges do not conform as above, then suitable temperature controlling devices should be installed to achieve this.

5 INSTALLATION GUIDE

5.1 B0992AA



Red, blue & yellow index pins are supplied in a bag. The appropriate coloured pin should be pressed in the handle.



1. Before connection, flush water through pipe-work to remove all debris etc. to prevent damage to the valve mechanism.

THEN ISOLATE WATER SUPPLIES.

2. Offer tap tail into basin hole, ensuring seal is in place & orientated as shown. If taps are fitted in pairs, HOT tap should be fitted on left hand side of the basin (viewed from front).

3. Hand tighten the back-nut, ensure the tap spout is positioned correctly, and then tighten the back-nut securely with a tap wrench (24mm A/F).

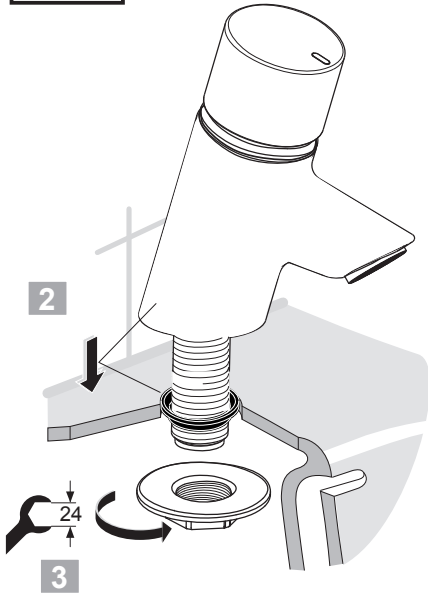

Remember to fit isolating valves*

Use a suitable swivel connector or compression fitting onto the end of the G1/2" tap tail. Secure water supply pipe to the tail.

RESTORE WATER SUPPLIES & CHECK ALL JOINTS FOR LEAKS

*Isolation valves should be fitted to permit future maintenance of this product. The cartridge mechanism includes a strainer.



DO NOT apply heat near this product. Heat generated by soldering could damage plastic parts and seals.

5.2 B0990AA & B1055AA



1. Before connection, flush water through pipe-work to remove all debris etc. to prevent damage to the valve mechanism. THEN ISOLATE WATERSUPPLIES.

1

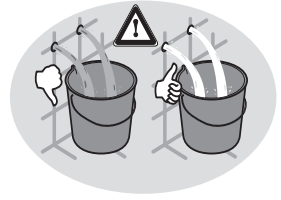

Remember to fit isolating valves*.

PREPARATION

These bib tap products require a G1/2" male threaded water supply nipple to be reinstalled in the wall (or mounting surface). The nipples should project forward about 15mm from the finished wall surface.

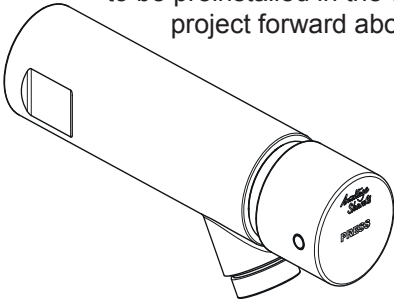

INSTALLATION HEIGHT:

The bib tap should be installed directly over a basin or similar vessel. Installations vary significantly; consideration should be given to the overall aesthetical appearance. Greater height may cause users to splash water outside the basin whereas lower height may reduce activity space.

If bib taps are fitted in pairs, HOT bib tap should be fitted on left hand side of the basin (viewed from front).

2. Apply suitable approved jointing medium to the nipple in the wall.

3. Hand tighten the bib tap onto the nipple, ensuring the outlet is positioned correctly downwards when the bib touches the wall.

It may be necessary to adjust the jointing compound to achieve the correct orientation of the outlet. In the worst case, fit a thin rubber washer between the wall & the bib tap. The remaining gap should be neatly filled with appropriate silicon sealant

RESTORE WATER SUPPLIES & CHECK ALL JOINTS FOR LEAKS



*Isolation valves should be fitted to permit future maintenance of this product. The cartridge mechanism includes a strainer.

DO NOT apply heat near this product. Heat generated by soldering could damage plastic parts and seals.

6 TAP OPERATION



B0992AA. To operate this product, simply press the handle downwards & then release. Water will flow for the pre-set time (adjustable in seconds) & then the tap will self-close.



B0990AA & B1055AA press handle horizontally.

7 OUTLET DETAILS



These products are factory fitted with a laminar PCA regulated outlet which is secured with an anti-vandal (AV) housing

Table 3 shows the flow rate performance for the flow regulator outlet

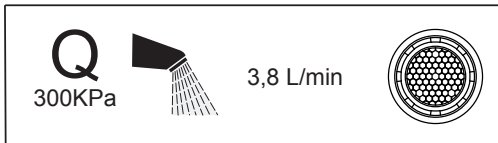
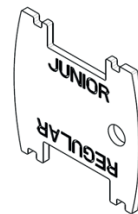
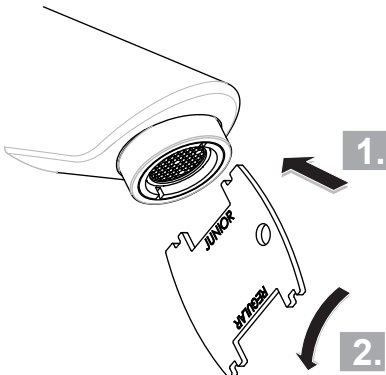

Table 3 Flow rate data (Q=flow rate)

To replace/clean/service the outlet, use the outlet key supplied with the product to unscrew the AV housing. **1.** Using the side of the key marked “junior” locate the key into the inner ring of the housing. **2.** Unscrew housing. Change the outlet & re-secure the housing with the key, ensuring the seal is in place. Ensure the outlet housing is adequately tightened to prevent leaks & run back.



8 RUN TIME ADJUSTMENT



These are water saving products & are supplied set with a short run time. A run time of typically 5 to 15 seconds will suit most applications.

The run time can be adjusted as detailed below; first the handle must be removed.

1 & 2 Handle removal

To remove the handle (B0992AA) prise out the small grommet located at the rear of the handle. (B0990AA & B1055AA on side of handle). Insert the 2.5mm hexagon key (supplied) into the hole & undo the grub screw a few turns. The handle should pull away from the tap body.

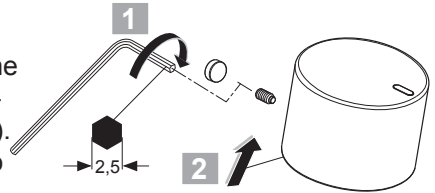

3. Adjustment

B0992AA: With the handle removed, engage the “run time adjustment key” (provided) into the cut-outs in the brass adjusting ring.

B0990AA & B1055AA: The adjusting ring can be turned with a small flat blade screw driver, key is not required.

Clockwise rotation will provide **longer** run time, & conversely anti-clockwise rotation will provide **shorter** run time. (Cartridge not shown for clarity).

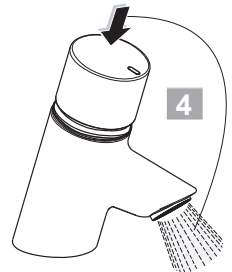
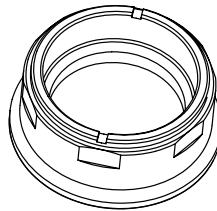
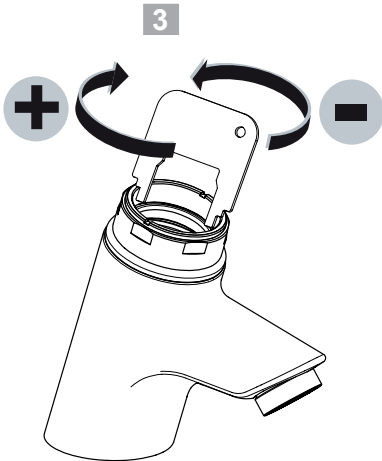

4. Check run time

Replace the handle temporarily & press it to check the run time. If the run time is satisfactory secure the handle (reverse sequence above). Otherwise remove the handle & make further adjustments.

9 MAINTANANCE (CLEARING PILOT HOLE)



In the event that the tap begins to run continuously, it will be necessary to manually clear the pilot hole inside the cartridge.

Handle removal: Firstly remove the handle as detailed in section 8. ENSURE WATER SUPPLIES HAVE BEEN ISOLATED.

Remove the cartridge from the tap body as detailed in section 10.

Complete cartridge sub assembly

Filter screen

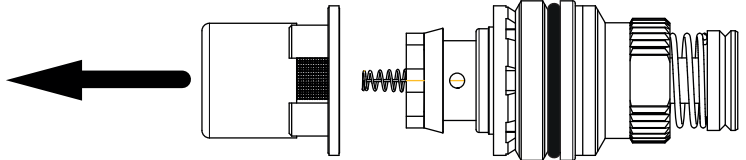
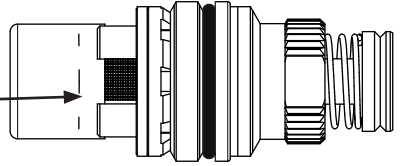

Gently pull off lower cartridge cap

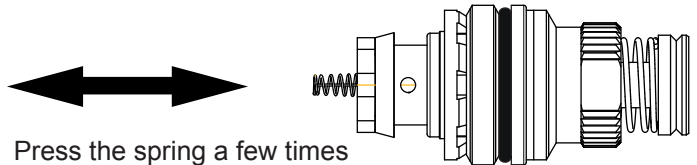

Press the spring a few times with a finger. This will exercise the pilot pin (integral to spring) and clear the pilot hole.

Before reassembling the cartridge cap, make sure that the filter screen is clean (slides out from inside of cap). When reassembling, take care to ensure the spring is straight & locates correctly into the boss at the bottom of the cap moulding.

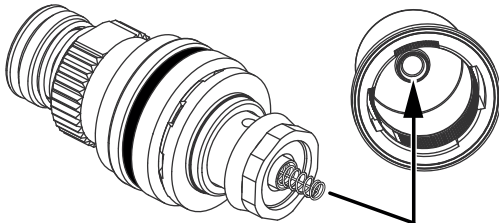

Finally refit the cartridge into the tap, reset the run-time & fit the handle

10 CARTRIDGE REPLACEMENT

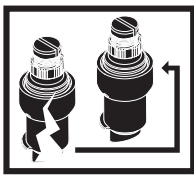

Before replacing the cartridge make sure:

1. The cartridge filter is not blocked with debris. If debris is found, clean the filter.
2. Check the pilot hole in the cartridge is clear.

For more details see section 9. After cleaning, refit the cartridge & recheck the product.

3. Handle removal: Firstly remove the handle as detailed in section 8. ENSURE WATER SUPPLIES HAVE BEEN ISOLATED.

4. With the handle removed, use a 40mm A/F spanner to unscrew the chrome shroud. Lift off the chrome shroud complete with brass adjusting ring.

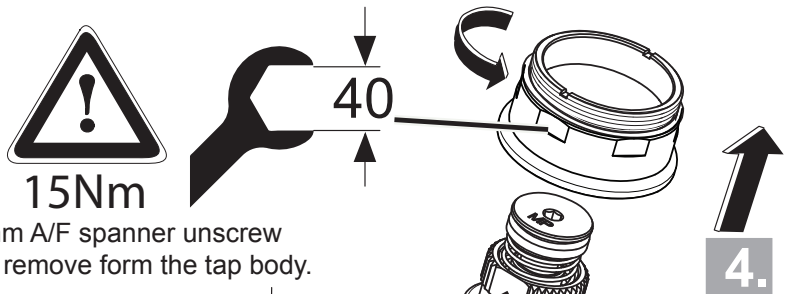

5. Using a 22mm A/F spanner unscrew the cartridge & remove from the tap body.

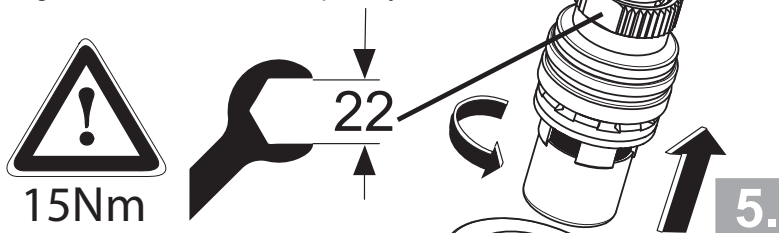

Fit a new cartridge; replace the chrome shroud with adjusting ring. Adjust the run time as detailed in section 8. Finally refit the handle.

TAKE CARE NOT TO DAMAGE CHROMED SURFACES.

11 SPARE PARTS

11.1 B0992AA

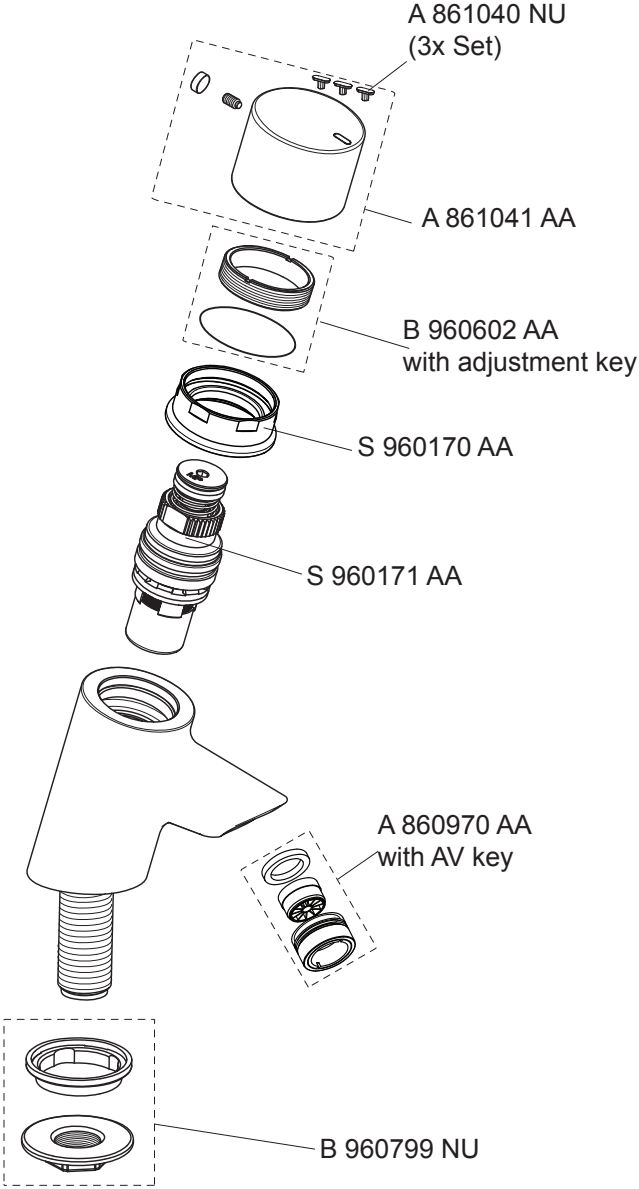

11.2 B0990AA & B1055AA



B 960745 NU

A 861040 NU

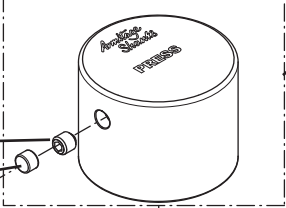

B0990AA:
E 960693 AA

B0155AA:
A861038AA

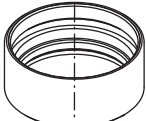
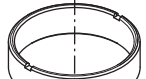
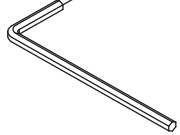

B 960739 AA

S 960171 AA

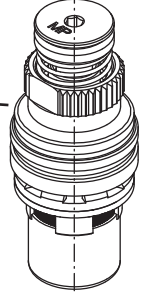

A 860970 AA
with AV key

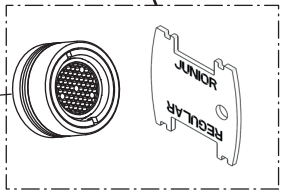
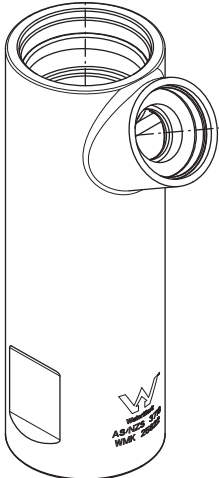

12 CLEANING CHROME SURFACES

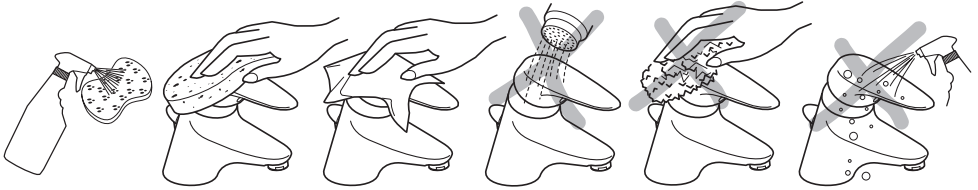

When cleaning chromed products use only a mild detergent, rinse & wipe dry with a soft cloth. Ideally clean after each use to maintain appearance.

Never use abrasive, scouring powders or scrapers. Never use cleaning agents containing alcohol, ammonia, hydrochloric acid, sulphuric acid, nitric acid, phosphoric acid or organic solvents. Use of incorrect cleaning products / methods may result in chrome damage which is not covered by the manufacturer's guarantee.

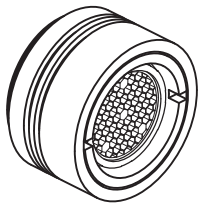

Outlet cleaning. On a regular basis the outlet should be inspected & cleaned. To unscrew and remove the outlet, see section 7.

In areas where lime scale build-up is prevalent this should be avoided by regular cleaning. If it should build up, it will have to be removed. An inhibited proprietary scale solvent can be used such as a kettle de-scaling solvent but it is important to follow the manufacturer's guidelines. After de-scaling it is important to rinse the parts thoroughly in clean water.

Clean carefully and do not use abrasive materials or scrapers.

13 AVON 21 PRODUCTS

Other self-closing products within the Avon 21 range:

*Armitage
Shanks*

B0993AA
Basin mixer with flexible inlet hoses

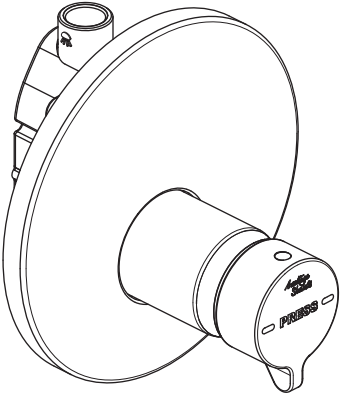
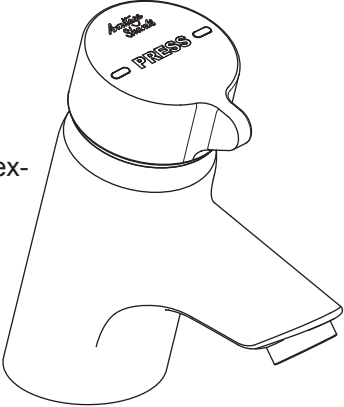

B0994AA
Built in shower mixer

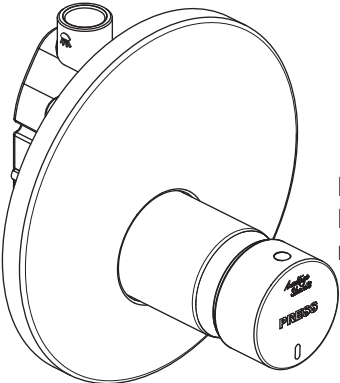

B0995AA
Built in shower non-mixer



CUSTOMER CARE HELPLINE

+44 (0)844 543 6170

CUSTOMER CARE FAX

+44 (0)844 543 6171

E-MAIL

aftersalesnonresidential@armitageshanks.co.uk

Armitage Shanks pursues a policy of continuing improvement in design and performance of its products.

This right is therefore reserved to vary specification without notice.

Armitage Shanks limited
Armitage
Near Rugeley
Staffordshire
WS15 4BT
England
+44 (0)870 122 8822

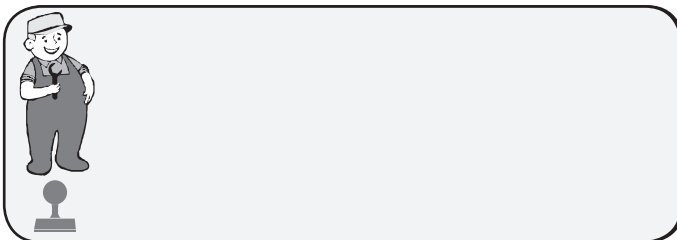

*Armitage
Shanks*

0818 / A 868 108
Made in Germany