

COOL-FIT 4.0

Pre-insulated system for industrial and commercial refrigeration

Increased efficiency and safety for food and beverage production
and for the storage of food





GF Piping Systems

Building the lifelines of the world

GF Piping Systems is the global specialist for the safe and reliable transportation of water, chemicals and gas. Customers in more than 100 countries implement our solutions to work more safely, efficiently and cost-effectively.

Your partner for modern plastic systems

Customers in more than 100 countries are already working with the plastic piping systems that GF Piping Systems introduced more than 60 years ago. They are maintenance-free, resistant to corrosive and aggressive media, and are extremely durable. Their low weight, compared to metal systems, reduces static and logistic requirements. An innovative design and modern jointing technology allows faster and easier installations. All this helps our customers to work more safely, efficiently and cost-effectively. Support throughout the transition from metal to plastic systems is a key focus for our specialists.

+ Maintenance-free plastic

Plastics are corrosion-free and maintenance-free. They have excellent chemical resistance and last as long as the system itself, which is more than 25 years.

+ Complete system solutions

Our portfolio of more than 60,000 products offers complete system solutions, meaning you get perfectly matched components from a single source.

+ Local support

GF Piping Systems specialists are located in 34 countries and are therefore always close at hand, meaning that advice and on-site practical assistance is never far away.

+ Partner in all project phases

The specialists from GF Piping Systems support you throughout all phases of your project – starting from the planning stage, right through to commissioning. This reduces both the time required and risks.

+ Many years of experience

GF Piping Systems is a division of Georg Fischer AG, based in Schaffhausen, Switzerland, which was established in 1802. You benefit from our many years of experience.

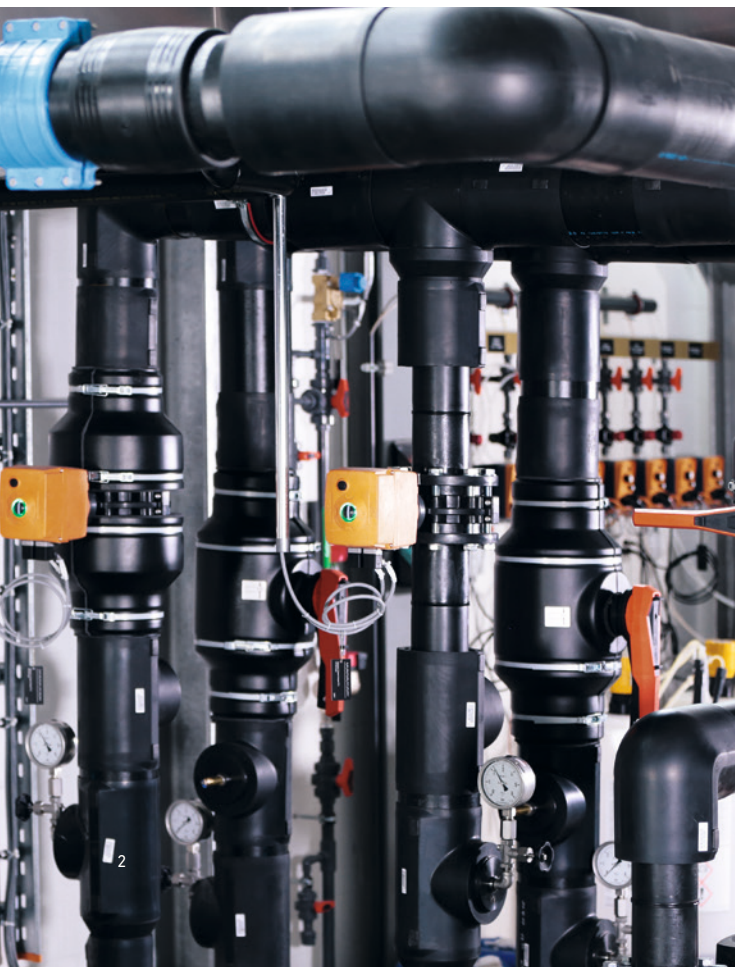



Efficient cooling with COOL-FIT 4.0

Poor insulation and corroding piping in cooling systems are more than just a nuisance, they pose a hazard to production safety and product quality. Moreover, they cause unnecessarily high maintenance and energy costs. GF Piping Systems offers solutions to help you to optimise your cooling system from the ground up. These solutions ensure continuous production processes, reduce operational downtimes due to leakages and other corrosion damage, and cut your maintenance and operating costs.

The pre-insulated COOL-FIT 4.0 piping system for commercial and industrial refrigeration is particularly beneficial for food and beverage manufacturers and processors. On the following pages, you will find out more about safe and efficient cooling with COOL-FIT 4.0 and how this system can support you.

Content

Building the lifelines of the world	2 – 3
Partner with GF Piping Systems	
Safe cooling has never been so easy	4 – 5
The benefits of COOL-FIT for you	
Increased safety and efficiency	6 – 11
COOL-FIT 4.0 for commercial and industrial refrigeration	
Applications	12 – 17
COOL-FIT 4.0 in food and beverage production, cold stores and breweries	
Connected within just a few minutes	18 – 20
Safe and reliable with electrofusion	
The Tool Box	21
Support from GF specialists and the cooling calculation tool	
Product range	22 – 69
The entire COOL-FIT 4.0 product range	



COOL-FIT

Safe, efficient cooling has never been so easy

COOL-FIT is the successful range of pre-insulated plastic piping systems from GF Piping Systems. It makes cooling applications more efficient than ever before – in all phases of your project. COOL-FIT simplifies planning and installation through superior design, pre-insulation, low weight and modern jointing technologies. COOL-FIT reduces costs through completely maintenance-free operation, energy efficiency, and longevity (more than 25 years). COOL-FIT is environmentally friendly, thanks to its low carbon dioxide emissions throughout the entire service life of the product. The specialists at GF Piping Systems support you in this during all project phases.



100% maintenance-free

The media pipe, insulation and jacket are made of plastic and therefore remain corrosion- and maintenance-free throughout the entire operating life of the system. This reduces expensive downtimes and lowers maintenance costs and personnel requirements.

100% reliable

The especially smooth interior surfaces of the medium pipe, typical for plastic systems, prevent deposits. The result: no loss of pressure over the entire service life. COOL-FIT remains as efficient as on its first day of operation.

65% less weight

COOL-FIT is significantly lighter than traditional metal systems and therefore places lower structural demands on buildings and supporting structures. The use of heavy transport aids can be reduced at the construction site.

50% faster installation

Factory pre-insulation eliminates the need for traditional insulation after the installation, which often requires a second team. You receive finished and permanently pre-insulated components, ready for immediate installation.

30% higher energy efficiency

In combination, the low thermal conductivity of plastic and the highly efficient foam insulation increase the energy efficiency of your system. This helps you to save energy costs and makes your work more environmentally friendly.



COOL-FIT 4.0

Maximum safety and efficiency for your production

COOL-FIT 4.0 is cutting-edge technology for users with the highest demands for production and process safety and for the storage of food. The pre-insulated piping system helps food and beverage manufacturers and processors to work at the highest level of safety and efficiency and to reduce costs.

Industrial and commercial refrigeration involves much more than just regulated temperatures. The focus is on production and process safety as well as the preservation of stored food. COOL-FIT 4.0 is the perfect solution for food and beverage manufacturers and processors.

COOL-FIT 4.0 is the pre-insulated piping system for secondary cooling with brine, glycol, ethanol and chilled water. It is ideal for temperatures ranging from -50°C to 60°C . COOL-FIT 4.0 is cutting-edge technology that benefits fruit and vegetable processors, slaughterhouses, breweries and supermarkets in particular. COOL-FIT 4.0 helps you to work with maximum efficiency and without disruption, while simultaneously reducing your maintenance and operating costs.

COOL-FIT 4.0 has the advantages of all COOL-FIT products compared to traditional metal systems:

- 100 % maintenance-free
- 100 % reliable
- 65 % less weight
- 50 % faster installation
- 30 % higher energy efficiency

In addition, COOL-FIT 4.0 offers further key benefits:

Connected within just a few minutes

COOL-FIT 4.0 allows for the simplest, safest and fastest possible installation – no unnecessary or complicated tasks. The system can be installed neatly and easily. Electrofusion permanently connects pipes, fittings and valves in just a few minutes.



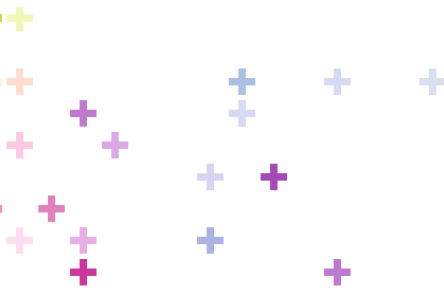

#9 overall ranking in the
4th Quarter of 2020
for Wall Streets Journals update
of the world's most sustainably
managed companies.

WSJ

Outdoor installation

COOL-FIT 4.0 can also be installed outdoors without any problems. All surfaces are sealed, weatherproof and UV-resistant. The sealing lip of the fittings surrounds the pipe and thus reliably protects the insulation from water and ice, ensuring a long service life.

Constant quality control

Thanks to the very few installation steps and the use of electrofusion as the jointing technology, COOL-FIT 4.0 enables a degree of control that was previously impossible. Installation errors are largely excluded from the outset, which ensures a system of the highest possible quality.

Clean and elegant system

Installing COOL-FIT 4.0 is safe and clean: no crumbling insulating foam, no sticky insulating tape or filling material, no open flame for closing the seals. The result is also aesthetically appealing, which is important for accessible plants and customer visits.



COOL-FIT for the environment

COOL-FIT helps you to work in a more environmentally friendly and energy-efficient manner.

Compared to post-insulated metal systems, COOL-FIT is considerably more environmentally friendly and helps to work more energy-efficiently. For example: a cold store uses 1500 metres of piping to transport cold water for the cooling system. COOL-FIT releases about 100 tonnes of carbon dioxide less than a metal system during production and operation. This saving is equivalent to a journey of 446,000 kilometres by car.

+ Carbon dioxide emission



+ Energy loss

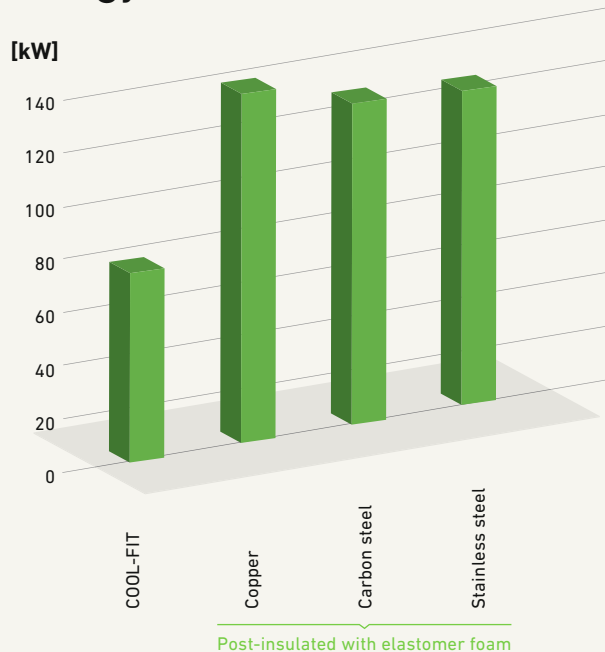

COOL-FIT is on average 30 percent more energy efficient than metal piping systems that were subsequently insulated with rubber-based foam, in an otherwise identical installation.

Leading technology for easy installation and longevity

COOL-FIT 4.0 is the result of years of development by our engineers with the aim of making the system even easier and faster to install, yet at the same time, remaining as safe, reliable and durable as you expect from all GF Piping Systems solutions. Many crucial details contribute to this.

System properties

* All three materials are permanently connected.

		COOL-FIT 4.0
Materials *	Media pipe	PE100
	Insulation	GF HE foam, halogen-free, closed-pore
	Outer jacket	Pipe: HDPE, fitting: GF-HE
Dimensions		d32 mm (DN25) – d450 mm (DN450)
Joining technology		Electrofusion joint
Pressure level	d32 – d110	PN 16 bar, SDR 11
	d160 – d450	PN 10 bar, SDR 17
Insulation	Thermal conductivity λ at 20°C	≤ 0.022 W/mK (d32 – d110), ≤ 0.026 W/mK (d160 – d450)
	Density	≥ 70 kg/m ³
	Foam cell size	max. \varnothing 0.5 mm
	Thickness (nominal value)	40 mm
Temperature	Medium	-50 °C to 60 °C (ambient -30 °C to 55 °C)
Weight (without liquid)	Pipe d32 mm	1.39 kg/m
	Pipe d225 mm	16.42 kg/m
Environment	Resistance	Moisture- and vapor-proof
	Ozone Depletion Potential (ODP)	Zero
Standards	EN ISO 15494	Plastic piping systems for industrial applications – Metric series
	ISO 7	Fittings
	EN ISO 16135, EN ISO 16138	Industrial valves

Chemical resistance to cooling agents

COOL-FIT 4.0 can be used with various types of cooling agents, such as:

- Water
- Organic salt solutions
- Inorganic salt solutions
- Water-Glycol mixtures up to 50%
- Ice slurry

Refer to the GF Planning Fundamentals for more detailed information.



System components



Pressure / Temperature

Medium: Water

Minimum service life: 25 years

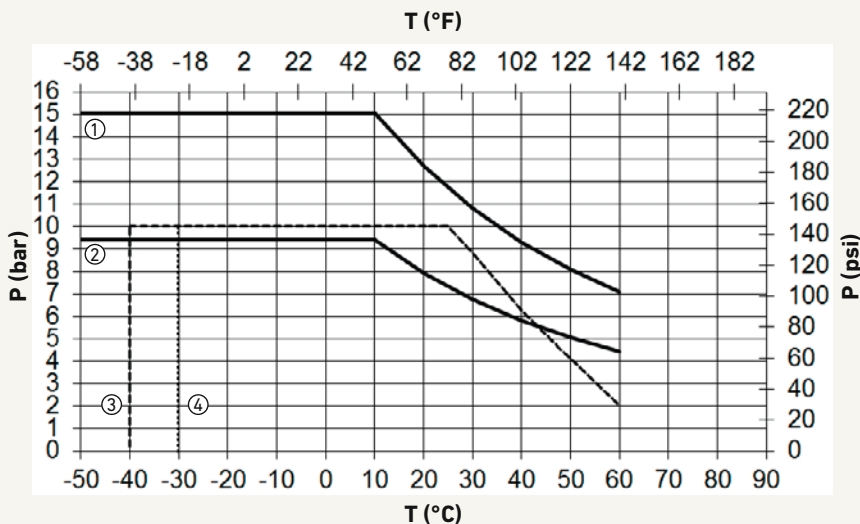

Note: With a water/glycol mixture $\leq 50\%$, the reduction factor for the pressure/temperature diagram 1.1 for pipes and fittings, and 1.7 for valves.

For PN16 or PN10 the safety factor is 1.25

P Operating pressure of the medium (bar, psi)
 T Temperature of the medium ($^{\circ}\text{C}$, $^{\circ}\text{F}$)
 C Safety factor

- ① COOL-FIT 4.0 pipe and fitting d32/D90 – d110/D180, C=1.6, SDR11
- ② COOL-FIT 4.0 pipe and fitting d160/D250 – d450/D630, C1.6, SDR17
- ③ COOL-FIT 4.0 ball valve PN10
- ④ COOL-FIT 4.0 butterfly valve PN10

R-Values of COOL-FIT 4.0 pipe

COOL-FIT 4.0 is a pre-insulated plastic piping system designed for cooling applications.

The COOL-FIT 4.0 R-values are based on measurements of thermal conductivity for the pre-insulated COOL-FIT 2.0 pipes, including materials of inner pipe, insulation and outer jacket are the same.

The determination of thermal conductivity at the pre-insulated COOL-FIT 4.0 pipes was carried out by the independent testing institute IMA (Materialforschung und Anwendungstechnik GmbH) in Dresden, Germany, following EN 15632-1, prEN 17414-1 and ISO 8497.

The calculation of areal thermal resistance R of the COOL-FIT pipe was performed according to ASTM C 335.

AS 1530.4 Fire Resistance Testing

FRL ratings available for all COOL-FIT 4.0 pipe d32 up to d250mm for concrete slab, plasterboard wall and speedpanel.

Testing and assessment conducted using Promat PROMASEAL FC100, FC150, FC250, FC300 Retrofit and HILITI Retrofit collars.

Report Numbers: FAS190295, FRT190416 and FRT190417.

Visit www.gfps.com/au to access reports or contact our customer service team for more information.

We hereby confirm the following R-values (COOL-FIT 4.0 pipes):

Dimension d/D (mm)	R-Value (m ² .K/w)
32/90	2.1
40/110	2.5
50/110	2.0
63/125	2.0
75/140	2.0
90/160	2.0
110/180	2.0
160/250	2.1
225/315	2.0
250/355	2.4
280/400	2.7
315/450	3.0
355/500	3.2
400/560	3.5
450/630	4.0

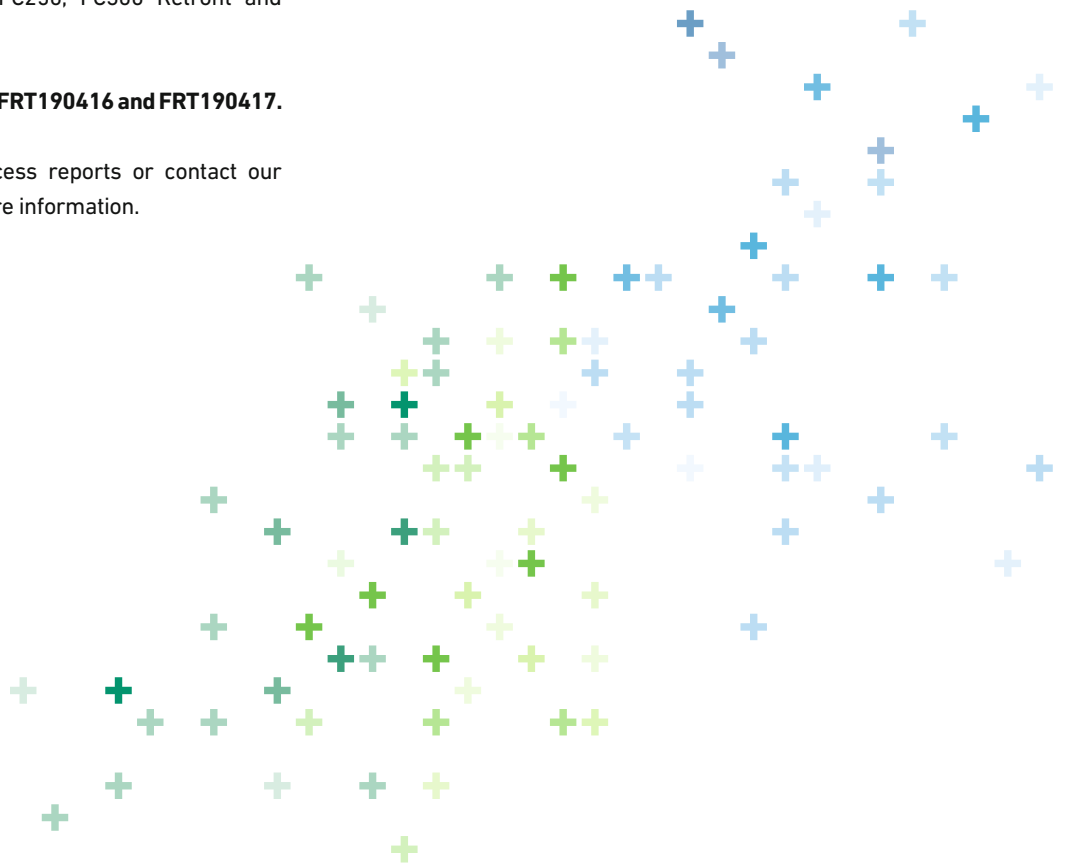

Adapting our business, to improve yours.

Pre-Fabrication & Customisation

GF Piping Systems can offer you support throughout your project, helping you bring your ideas and concepts to life. Take advantage of our experts and their extensive range of specialised plastic fabrication equipment for customised solutions, tailored made for your specifications. We combined our global footprint with more than 50+ years' of experience working with thermoplastic products, with our local knowledge of the market and our customers' needs to meet their requirements.

Manufacturing

We are here for your peace-of-mind, providing your project with completed flanged spool assemblies from a single source that can simply be bolted together on-site using in-house technicians, thereby saving the time and expense of hiring certified contractors and renting welding equipment.

Fabrication Capabilities

- Fabricated Tees and Sweep Bends up to 800 mm
- Butt Welding: 63 mm – 800 mm
- Electrofusion Welding: 20mm – 1,200 mm
- Saddle Welding
- System Assembly
- Spool and Header Manufacturing
- Extrusion Welding
- Rooftop Water Distribution Modules
- High Point Vents (HPV) and Low Point Drains (LPD) for Coal Seam Gas
- Hydrostatic Pressure Testing
- Signet Assemblies Remote Devices
- Many more ...

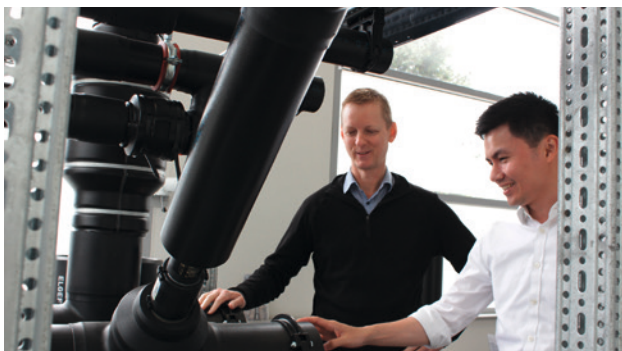
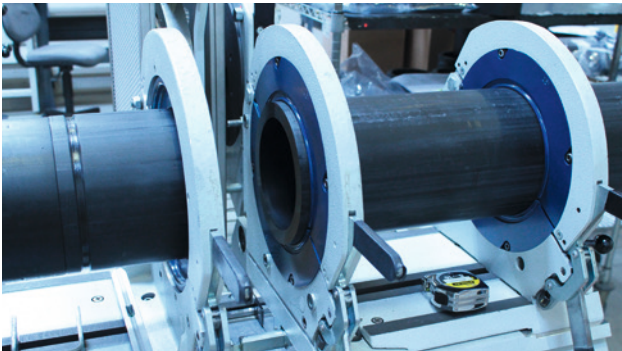

Food and Beverage Production

Reduced production costs

During the manufacturing and processing of food and beverages, reliable cooling is essential for production that is both faultlessly hygienic and economically efficient. COOL-FIT 4.0 eliminates the risk of downtimes caused by corrosion damage in the cooling system and helps to comply with increasing environmental regulations. COOL-FIT 4.0 is ideal for conversion of secondary cooling systems and connection to existing systems.

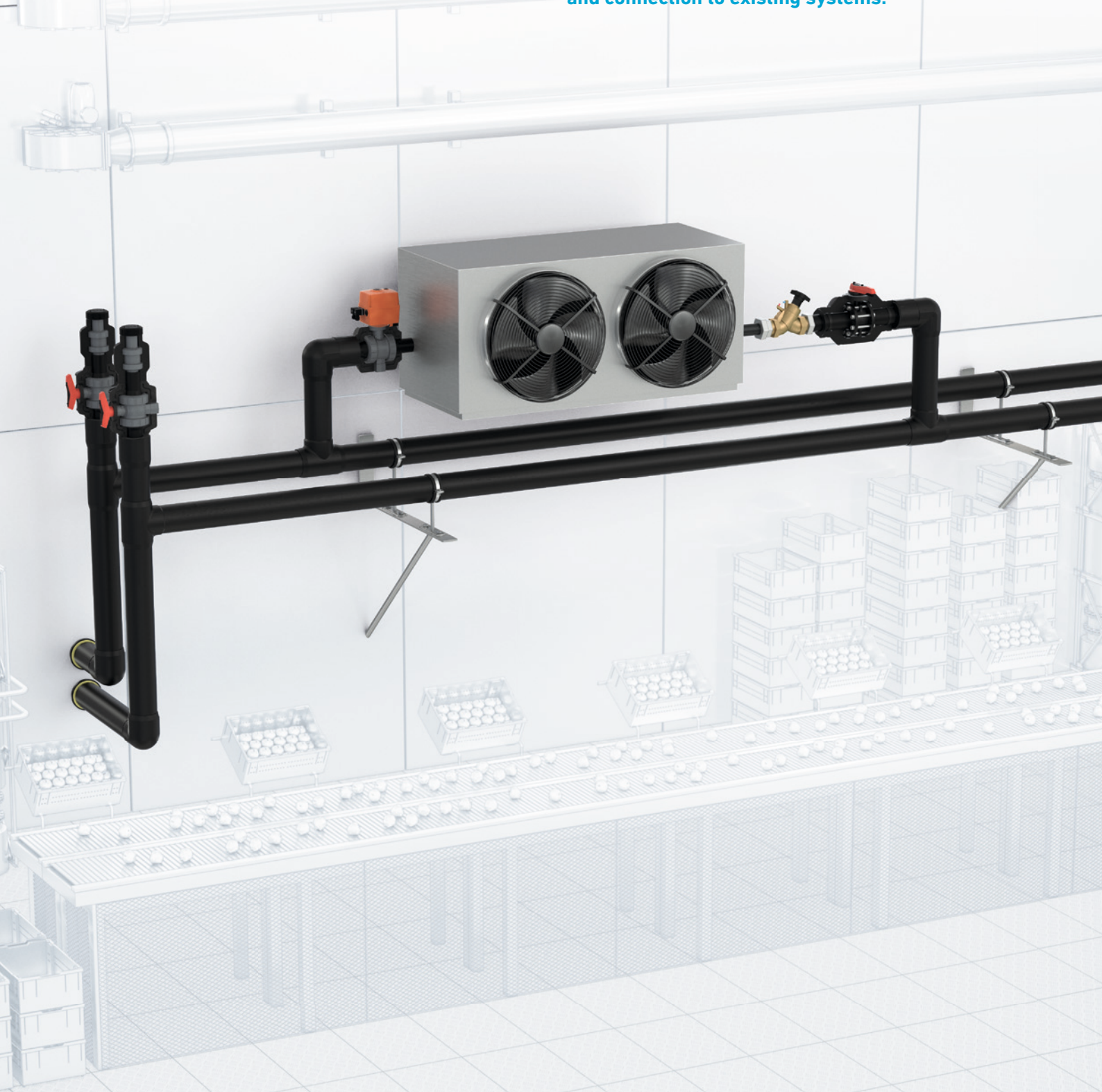



Easy transitions to metal systems

The COOL-FIT 4.0 adapter fittings enable simple and fast transition to metal systems, valves, end devices and chillers, allowing for effortless connection of adjacent systems.



Pre-insulated electrofusion fittings

The range of COOL-FIT 4.0 fittings includes pre-insulated elbows, tees, couplers and reducers. Electrofusion ensures secure joints within just a few minutes, with integrated quality control.

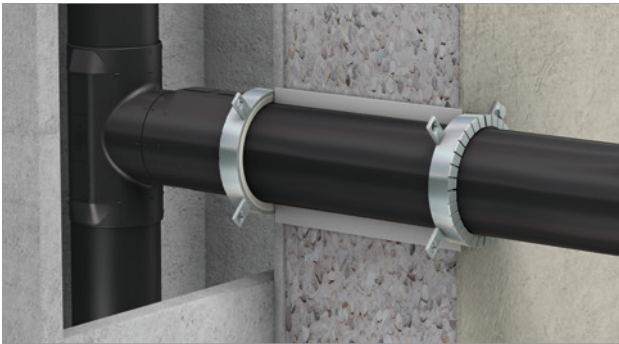

Certified fire protection collars

Often, food and beverage production take places across several compact production areas. In the event of a fire, the fire protection collars reliably seal them off from each other for up to 120 minutes.



Proven fixed point solutions

The fixed point solutions from GF Piping Systems can be welded easily onto the outer jacket. They ensure professional, tension-free installation of COOL-FIT 4.0, even under difficult fitting conditions.

Your benefits

- Highest degree of protection from production downtimes and loss of goods caused by corrosion damage
- Ideal for conversion to secondary cooling to meet environmental regulations
- Fast installation and commissioning with pre-insulation and electrofusion
- Support throughout all project phases provided by local specialists from GF Piping Systems



Cold Stores

Safety throughout the cold chain

In cold stores, the reliability of the system determines the preservation of the stock and thus the economic base of the company. COOL-FIT 4.0, as a high-quality plastic system, eliminates the risk of interruptions in the cold chain and product losses due to corrosion. The system can also be installed outdoors, if required. The outstanding insulation properties of COOL-FIT 4.0 make it possible to reduce cooling costs and to work more profitably.

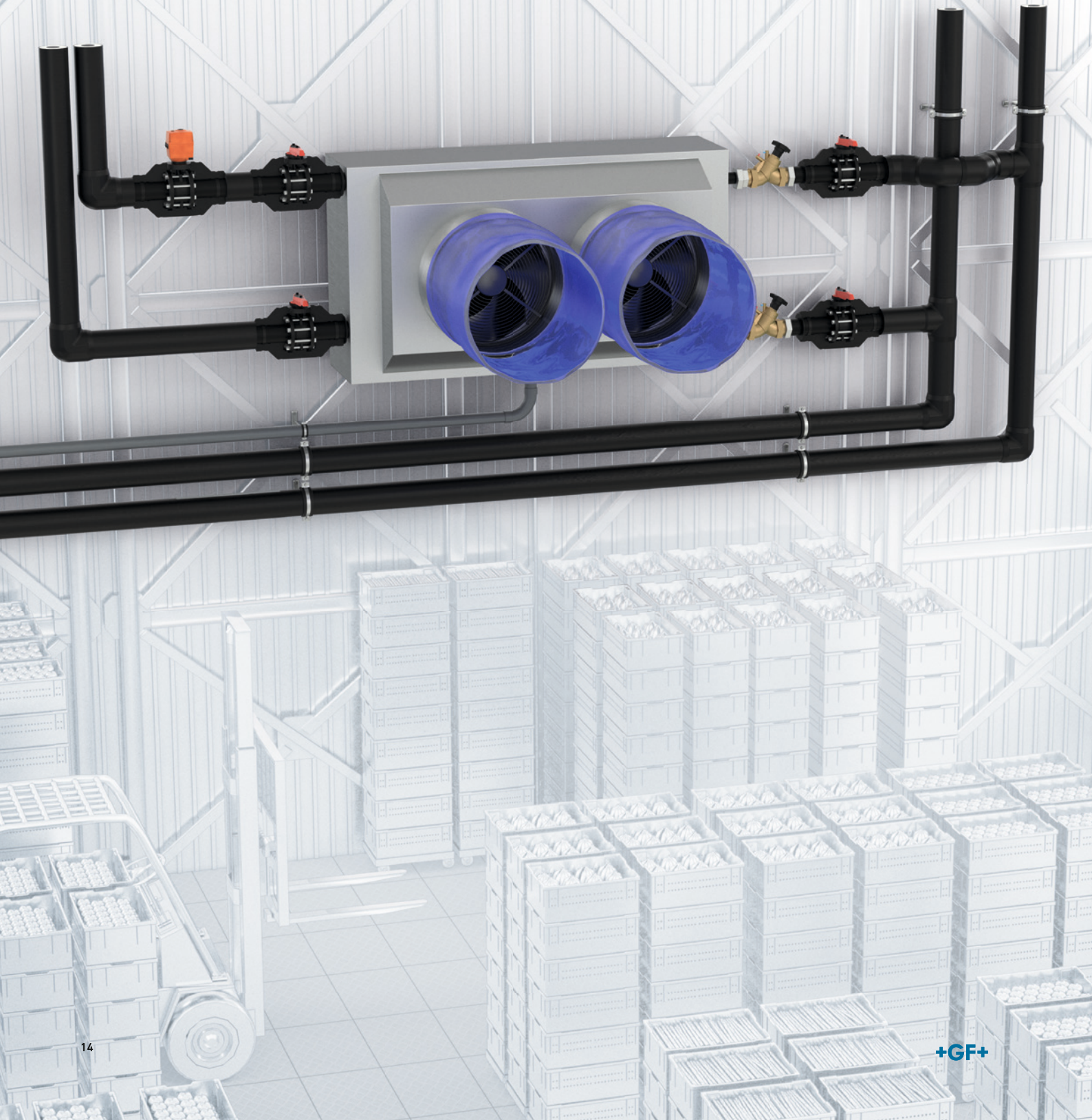



Pre-insulated pipes for fast installation

In cold stores, long, straight pipe sections are common due to their often considerable size. The pre-insulation of COOL-FIT 4.0 supports fast installation, with all pipes stripped at both ends at the factory.



Uncomplicated flange connections

Connection to existing metal systems is made straightforward with the use of flange connections. The COOL-FIT 4.0 range includes the appropriate flange adaptor, which is precisely encased by the insulation shells.



Pre-insulated butterfly valves

In addition to ball valves, butterfly valves are among the most frequently used valves in cold stores. They are pre-insulated in the COOL-FIT 4.0 system, just like all other system components. They are available from d110 to d225 as standard.

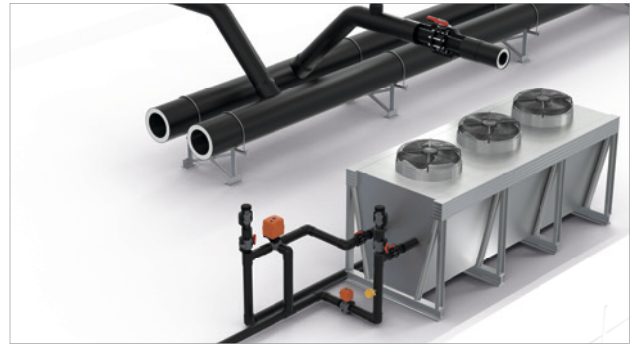

Safe even when installed outdoors

In order to use production areas efficiently, it is often necessary to relocate part of the installation outdoors, such as on the roof. No problem for COOL-FIT 4.0: the system is watertight, weatherproof and resistant to UV radiation.

Your benefits

- Highest degree of protection against system failures by means of corrosion-free plastic components
- Safe outdoor installation (e.g. on the roof) without any additional protective elements
- Fast installation and commissioning with pre-insulation and electrofusion
- Support throughout all project phases provided by local specialists from GF Piping Systems



Breweries

Corrosion-free production

Corrosion resistance is particularly important in breweries, because to the constant use of water and liquid primary products. COOL-FIT 4.0, as a pre-insulated plastic system, is ideal for this use, especially for control and conditioning the fermentation. The installation in historical production buildings and irregularly shaped storage cellars can be challenging. Our local specialists are available to support you during each project phase.





Electrical valves with pre-insulation

In addition to butterfly valves, the COOL-FIT 4.0 range includes ball valves, operated manually or electrically. They are pre-insulated, as is the entire system, and are therefore as quick and easy to install as all the other components.



Flexible hoses for the tanks

Fermentation tanks often have no clearly defined angles on their slightly irregular arched undersides, making it difficult to install normal fittings. Here, pre-insulated flexible hoses ensure a secure connection.



Installation fittings for sensors

Sensors for measuring pressure, temperature and other variables can be easily integrated with installation fittings. The sensors are screwed in, drilling is not necessary. This method reduces the risk of leakage.

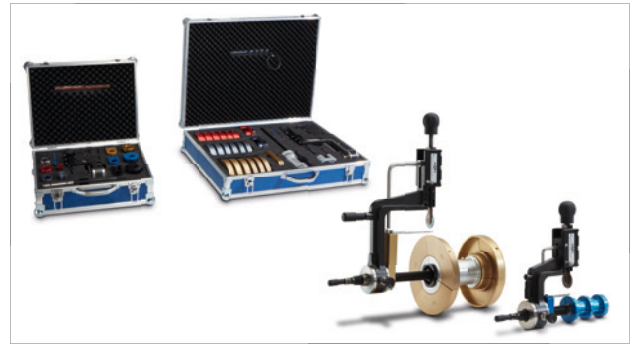

Range of tools and training

The tools from GF Piping Systems enable the installer to achieve a fast and high-quality installation of COOL-FIT 4.0. Our local specialists also provide support with training sessions, if required.

Your benefits

- **Cost reduction thanks to a corrosion-free, and thus maintenance-free, piping system**
- **Flexibility during system planning thanks to a wide range of pre-insulated components**
- **Fast installation and commissioning with pre-insulation and electrofusion**
- **Support throughout all project phases provided by local specialists from GF Piping Systems**



Joined in minutes by electrofusion

The COOL-FIT 4.0 pipes, fittings and valves can be connected neatly, easily and within just a few minutes by electrofusion. On this page you can find the most important processing steps and the technical differences among the dimension ranges d32 - d225 and d250 - d450.

Diameter d32 – d225

Features & Processing steps nominal

- The pipes are already stripped and peeled on delivery
- A sealing lip seals the insulations from each other
- All fittings are available as an electrofusion version

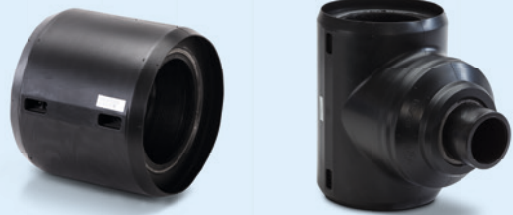

Clean the fusion zones of the fitting and pipe using a clean cloth.



Place the mounting aid on the fitting. Stretch the sealing lip pressing the handles together.



Slide the ends of the pipe into the fitting as far as the marking. Then remove the mounting aid.



Connect the welding cables to the welding contacts of the fitting and weld according to the instruction manual.

One of the most significant benefits of COOL-FIT 4.0 is the clean, simple and fast installation by electrofusion. Even plumbers without any training in welding find it easy to install COOL-FIT 4.0 and check the quality of the installation.

For installation videos:

gfps.com/au



Diameter d250 – d450

Features & Processing steps nominal

- Pipes and fittings must be peeled before installation
- Insulations are sealed from each other with a sealing tape and shrink sleeves
- Spigot fitting (type B) connected with electrofusion coupler (type A)

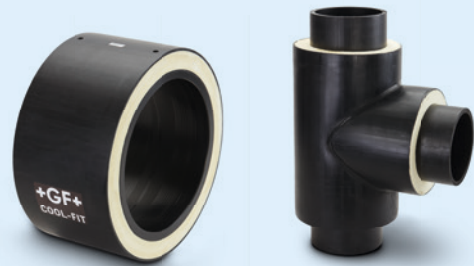

Peel the ends of the pipe and fitting type B and clean the fusion zones of the fitting and pipe using a clean cloth.



Slide-on the shrink sleeves and push the pipe ends up to the stop into the electrofusion coupler.



Connect the welding cables to the welding contacts of the fitting and weld according to the instruction manual.



Seal the jointing face between the fitting and pipe with sealing tape and shrink the shrink sleeves.

Heat Tracing

The heat-tracing system for COOL-FIT 4.0 offers an effective solution for the freeze protection of COOL-FIT lines. The self-regulating heating cable in combination with the insulation of the COOL-FIT 4.0 pipe system prevents the cooling pipe from freezing.

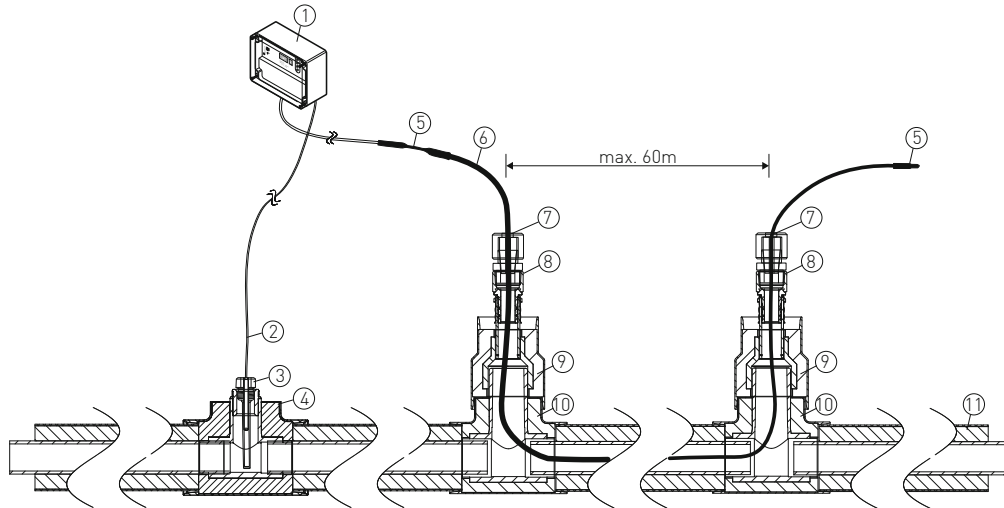

No. Designation

1	Thermostat
2	Temperature sensor PT 100
3	Immersion sleeve for PT sensor
4	COOL-FIT 4.0 installation fitting 1/2" Rp

No. Designation

5	Cold lead connection and end seal kit
6	Heating cable
7	Cable glands 3/4" male thread R
8	Adaptor fitting d32-3/4" female thread Rp

No. Designation

9	COOL-FIT 4.0 reducer to d32
10	COOL-FIT 4.0 T90°
11	COOL-FIT 4.0 pipe



Function

The COOL-FIT heat-tracing system uses a self-regulating heat-tracing cable installed inside the pipe. This efficiently protects the medium from freezing directly and without heat loss through the pipe wall insulation.

The entry and exit of the cable into the COOL-FIT system is performed via cable glands, which are connected to the COOL-FIT system via metallic thread transitions. The thermostat with surface sensor enables efficient control directly via the media temperature.

The temperature sensor is installed via COOL-FIT installation fittings using a suitable immersion sleeve.

With the COOL-FIT 4.0 heat tracing, reliable frost protection down to -30°C ambient temperature is provided across all COOL-FIT 4.0 dimensions from d32 - d450.

Self-regulating technology

The self-regulating technology automatically adjusts the heating output at each point to the ambient temperature. It never overheats even when overlapped.

How can COOL-FIT 4.0 help you?

+ Support from GF specialists

COOL-FIT 4.0 is a technically superior system. And it is more than the sum of its components, because it is supplemented by service from GF Piping Systems in all phases of your project – starting from the planning stage, right through to commissioning. You can find our local specialists in 34 countries, meaning they are always close at hand. This also allows for personal discussions at your company, as well as at the construction site during the installation phase.

With GF Piping Systems at your side, you can always count on having a competent contact person. This includes assistance with the necessary calculations, especially if you have little experience with plastic systems, as well as product selection, installation and final quality inspection.

+ Next steps

- Consultation with your GF Piping Systems specialists
- Consultation on the benefits of COOL-FIT 4.0 for you
- Information on reference applications
- Assistance with product selection and making calculations
- Support throughout all project phases

Get in touch with us
gfps.com/cf4-contact

For online calculator:
gfps.com/cooling-tools



COOLING Tool-Box

The cooling calculation tool from GF Piping Systems supports the dimensioning and design of the secondary circuit. The cooling calculation tool includes the following calculation functions:

- Expansion / contraction
- Length of the flexible sections
- Energy saving
- Surface temperatures
- Pipe dimensioning
- Pressure losses
- Dew point, including insulation strength
- Bracket spacing
- Freezing time
- Weight comparison
- CO₂ footprint

BIM/Revit Library
www.bim.gfps.com

CAD Library
<https://cad.georgfischer.com>

For Design Software Centre:
bim.gfps.com

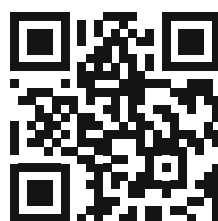

COOL-FIT 4.0

Product range



COOL-FIT 4.0 Pipes

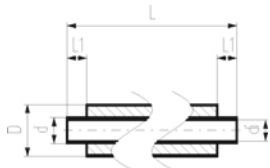

COOL-FIT 4.0 Pipe, d32-d225

Model:

- Pre-insulated PE100 SDR11/17 metric
- Insulation made from GF HE foam
- Impact resistant. Colour: black
- Length: 5m
- With free ends for electrofusion

d/D (mm)	DN (mm)	SDR (bar)	PN (bar)	Code GF	Code Reece	Weight (kg/m)	di (mm)	L (mm)	L1 (mm)	Closest Inch (inch)
32/90	25	11	16	738 173 108	1470335	1.411	26.2	5000	36	1
40/110	32	11	16	738 173 109	1470336	2.054	32.6	5000	40	1 ¼
50/110	40	11	16	738 173 110	1470337	2.221	40.8	5000	44	1 ½
63/125	50	11	16	738 173 111	1470338	2.987	51.4	5000	48	2
75/140	65	11	16	738 173 112	1470339	3.757	61.4	5000	55	2 ½
90/160	80	11	16	738 173 113	1470340	4.819	73.6	5000	62	3
110/180	100	11	16	738 173 114	1470341	6.200	90.0	5000	72	4
160/250	150	17	10	738 173 117	1470342	9.921	141.0	5000	90	6
225/315	200	17	10	738 173 120	1470343	16.620	198.2	5000	110	8

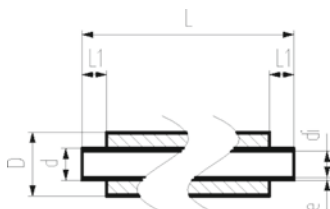
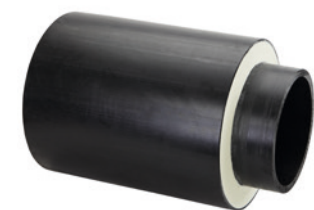

COOL-FIT 4.0 Pipe, d250-d450

Model:

- Pre-insulated PE100 SDR 17 metric
- Insulation made from GF HE foam
- Outer jacket impact resistant. Colour: black
- Length: 5.9m
- With free ends for electrofusion

d/D (mm)	PN (bar)	Code GF	Code Reece	Weight (kg/m)	di (mm)	L (mm)	L1 (mm)	Closest Inch (inch)
250/355	10	738 173 021	1470487	18.180	220.4	5900	123	10
280/400	10	738 173 022	1470488	22.640	246.8	5900	126	10
315/450	10	738 173 023	1470489	28.510	277.6	5900	133	12
355/500	10	738 173 024	1470490	35.350	312.8	5900	148	14
400/560	10	738 173 125	1470491	44.070	352.6	5900	150	16
450/630	10	738 173 126	1470492	55.490	396.6	5900	165	18

COOL-FIT 4.0 Fittings



COOL-FIT 4.0 Coupler, d32-d225

Model:

- Pre-insulated PE100 SDR 11 metric
- Insulation made from GF HE foam
- Impact resistant. Colour: black
- Integrated sealing lip, for a moisture-proof and vapour tight sealing

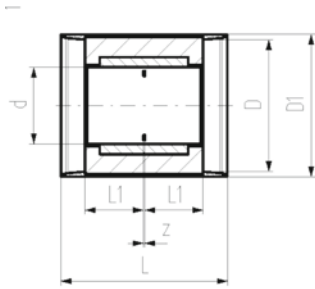

d/D (mm)	DN (mm)	PN (bar)	Code GF	Code Reece	Weight (kg)	D1 (mm)	L (mm)	L1 (mm)	z (mm)	Closest Inch (inch)
32/90	25	16	738 913 108	1470344	0.089	97	127	36	5	1
40/110	32	16	738 913 109	1470345	0.129	117	133	40	3	1 ¼
50/110	40	16	738 913 110	1470346	0.169	117	141	44	3	1 ½
63/125	50	16	738 913 111	1470347	0.240	132	149	48	3	2
75/140	65	16	738 913 112	1470348	0.520	147	163	55	3	2 ½
90/160	80	16	738 913 113	1470349	0.750	168	178	62	4	3
110/180	100	16	738 913 114	1470350	0.831	188	198	72	4	4
160/250	150	16	738 913 117	1470351	1.726	258	233	90	3	6
225/315	200	16	738 913 120	1470352	3.783	324	275	110	5	8

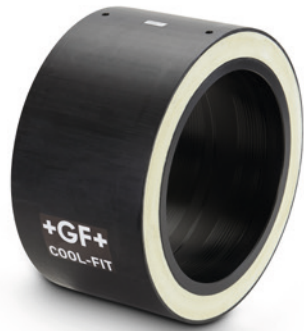

COOL-FIT 4.0 Coupler, d250-d450

Model:

- Pre-insulated PE100 SDR 17 metric
- Insulation made from GF HE foam
- Outer jacket impact resistant. Colour: black

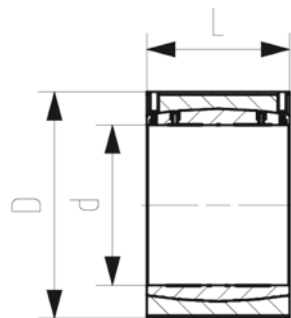

d/D (mm)	PN (bar)	Code GF	Code Reece	Weight (kg)	L (mm)	Closest Inch (inch)
250/355	10	738 911 821	1470527	6.290	247	10
280/400	10	738 911 822	1470601	8.020	252	10
315/450	10	738 911 823	1470528	9.110	267	12
355/500	10	738 911 824	1470526	13.780	290	14
400/560	10	738 911 875	1470603	23.450	294	16
450/630	10	738 911 876	1470529	22.590	326	18



COOL-FIT 4.0 Elbow 90°, d32-d225

Model:

- Pre-insulated PE100 SDR11, metric
- Insulation made from GF HE foam
- Outer jacket impact resistant. Colour: black
- A: Electrofusion Fitting with integrated sealing lip, for a water and vapour tight sealing

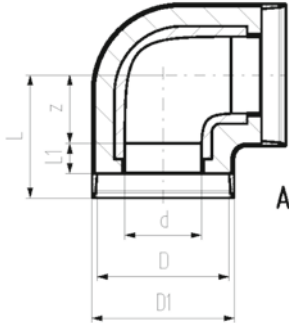

d/D (mm)	PN (bar)	Code GF	Code Reece	Weight (kg)	D1 (mm)	L (mm)	L1 (mm)	z (mm)	Closest Inch (inch)	Type
32/90	16	738 103 108	1470353	0.255	97	81	36	20	1	A
40/110	16	738 103 109	1470354	0.177	117	88	40	23	1 ¼	A
50/110	16	738 103 110	1470355	0.250	117	99	44	30	1 ½	A
63/125	16	738 103 111	1470356	0.372	132	107	48	34	2	A
75/140	16	738 103 112	1470357	0.800	147	120	55	40	2 ½	A
90/160	16	738 103 113	1470358	1.500	168	150	62	63	3	A
110/180	16	738 103 114	1470359	1.950	188	174	72	77	4	A
160/250	16	738 103 117	1470360	5.200	258	220	90	105	6	A
225/315	16	738 103 120	1470361	12.400	324	345	110	210	8	A

COOL-FIT 4.0 Bend 90°, d250-d450

Model:

- Pre-insulated PE100 SDR 17 metric
- Insulation made from GF HE foam
- Outer jacket impact resistant. Colour: black
- B: Spigot Fitting with free end (separate electrofusion fitting needed for joining)

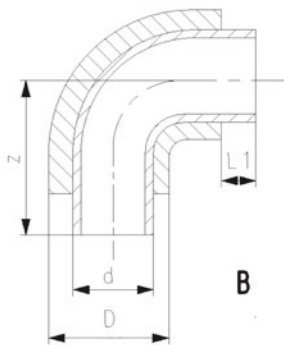

d/D (mm)	PN (bar)	Code GF	Code Reece	Weight (kg)	L1 (mm)	z (mm)	Closest Inch (inch)	Type
250/355	10	738 003 121	1470475	11.800	123	375	10	B
280/400	10	738 003 122	1470476	16.560	126	430	10	B
315/450	10	738 003 123	1470477	28.800	133	470	12	B
355/500	10	738 003 124	1470478	25.000	148	900	14	B
400/560	10	738 003 175	1470479	59.640	150	980	16	B
450/630	10	738 003 176	1470480	79.200	165	1070	18	B



COOL-FIT 4.0 Elbow 45°, d32-d225

Model:

- Pre-insulated PE100 SDR11, metric
- Insulation made from GF HE foam
- Outer jacket impact resistant. Colour: black
- A: Electrofusion Fitting with integrated sealing lip, for a water and vapour tight sealing

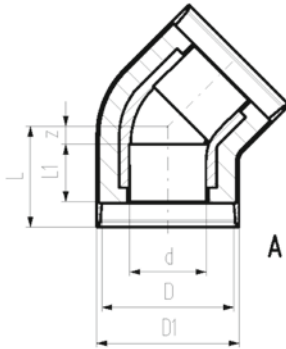

d/D (mm)	PN (bar)	Code GF	Code Reece	Weight (kg)	D1 (mm)	L (mm)	L1 (mm)	z (mm)	Closest Inch (inch)	Type
32/90	16	738 153 108	1470362	0.108	97	72	36	11	1	A
40/110	16	738 153 109	1470363	0.162	117	76	40	11	1 ¼	A
50/110	16	738 153 110	1470364	0.218	117	82	44	13	1 ½	A
63/125	16	738 153 111	1470365	0.315	132	89	48	16	2	A
75/140	16	738 153 112	1470366	0.650	147	98	55	18	2 ½	A
90/160	16	738 153 113	1470367	1.030	168	117	62	30	3	A
110/180	16	738 153 114	1470368	1.270	188	138	72	41	4	A
160/250	16	738 153 117	1470369	4.100	258	161	90	46	6	A
225/315	16	738 153 120	1470370	17.603	324	278	110	143	8	A

COOL-FIT 4.0 Bend 45°, d250-d450

Model:

- Pre-insulated PE100 SDR 17 metric
- Insulation made from GF HE foam
- Outer jacket impact resistant. Colour: black
- B: Spigot Fitting with free end (separate electrofusion fitting needed for joining)

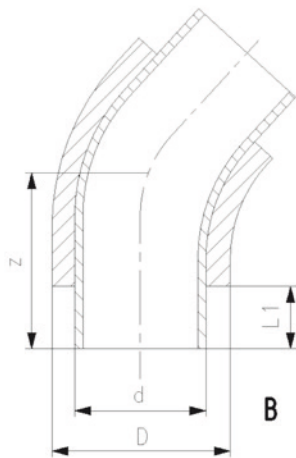

d/D (mm)	PN (bar)	Code GF	Code Reece	Weight (kg)	L1 (mm)	z (mm)	Closest Inch (inch)	Type
250/355	10	738 053 121	1470481	12.840	123	440	10	B
280/400	10	738 053 122	1470482	18.000	126	460	10	B
315/450	10	738 053 123	1470483	21.360	133	535	12	B
355/500	10	738 053 124	1470484	18.720	148	620	14	B
400/560	10	738 053 175	1470485	43.920	150	650	16	B
450/630	10	738 053 176	147048	54.360	165	680	18	B



COOL-FIT 4.0 T90° equal, d32-d225

Model:

- Pre-insulated PE100 SDR11, metric
- Insulation made from GF HE foam
- Outer jacket impact resistant. Colour: black
- A: Electrofusion Fitting with integrated sealing lip, for a water and vapour tight sealing

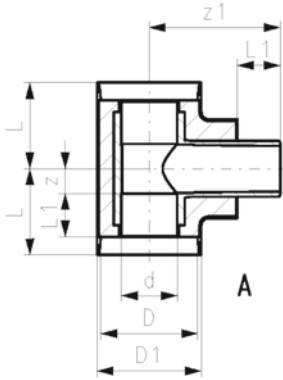

d/D (mm)	PN (bar)	Code GF	Code Reece	Weight (kg)	D1 (mm)	L (mm)	L1 (mm)	z (mm)	z1 (mm)	Closest Inch (inch)	Type
32/90	16	738 203 108	1470371	0.161	97	79	36	18	118	1	A
40/110	16	738 203 109	1470372	0.257	117	87	40	22	132	1 ¼	A
50/110	16	738 203 110	1470373	0.342	117	94	44	25	138	1 ½	A
63/125	16	738 203 111	1470374	0.514	132	103	48	30	154	2	A
75/140	16	738 203 112	1470375	1.000	147	116	55	36	168	2 ½	A
90/160	16	738 203 113	1470376	1.400	1668	130	62	43	187	3	A
110/180	16	738 203 114	1470377	2.500	188	154	72	57	207	4	A
160/250	16	738 203 117	1470378	5.600	258	192	90	77	263	6	A
225/315	16	738 203 120	1470379	16.748	324	355	110	220	337	8	A

COOL-FIT 4.0 T90° equal, d250-d450

Model:

- Pre-insulated PE100 SDR 17 metric
- Insulation made from GF HE foam
- Outer jacket impact resistant. Colour: black
- B: Spigot Fitting with free end (separate electrofusion fitting needed for joining)

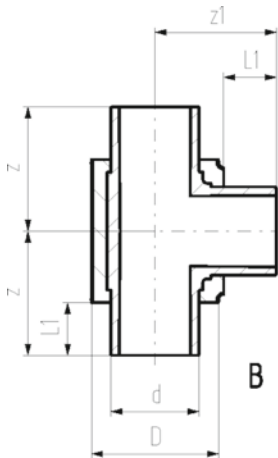

d/D (mm)	PN (bar)	Code GF	Code Reece	Weight (kg)	L1 (mm)	z (mm)	z1 (mm)	Closest Inch (inch)	Type
250/355	10	738 203 121	1470493	12.000	123	500	500	10	B
280/400	10	738 203 122	1470494	22.300	126	500	500	10	B
315/450	10	738 203 123	1470495	21.480	133	500	500	12	B
355/500	10	738 203 124	1470496	30.600	148	650	700	14	B
400/560	10	738 203 175	1470497	42.000	150	650	700	16	B
450/630	10	738 203 176	1470498	67.200	165	700	750	18	B

COOL-FIT 4.0 T90° reduced, d32-d225



Model:

- Pre-insulated PE100 SDR11, metric
- Insulation made from GF HE foam
- Outer jacket impact resistant. Colour: black
- A: Electrofusion Fitting with integrated sealing lip, for a water and vapour tight sealing
- *Available as long as stocks last

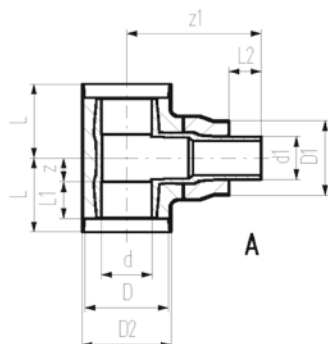

d/D (mm)	d1/D1 (mm)	PN (bar)	Code GF	Code Reece	Weight (kg)
75/140	63/125	16	738 203 218	1470380	0.863
90/160	63/125	16	738 203 222	1470381	1.232
90/160	75/140	16	738 203 223	1470382	1.293
110/180	63/125	16	738 203 227	1470383	1.972
110/180	75/140	16	738 203 227	1470384	1.949
110/180	90/160	16	738 203 229	1470385	2.037
* 160/250	63/125	16	738 203 247	1470386	5.150
* 160/250	90/160	16	738 203 249	1470387	5.147
* 160/250	110/180	16	738 203 250	1470388	5.220
160/250	140/200	16	738 203 251	-	5.540
225/315	63/125	16	738 203 264	1470389	16.832
225/315	90/160	16	738 203 266	1470390	16.889
225/315	110/180	16	738 203 267	1470391	16.805
225/315	140/200	16	738 203 268	-	17.100
225/315	160/250	16	738 203 269	1470392	18.500
160/250	63/125	16	738 203 447	-	5.150
160/250	90/160	16	738 203 449	-	5.147
160/250	110/180	16	738 203 450	-	5.220

d/D (mm)	d1/D1 (mm)	D2 (mm)	L (mm)	L1 (mm)	L2 (mm)	z (mm)	z1 (mm)	Closest Inch (inch)	Type
75/140	63/125	147	116	55	48	36	228	2 ½	A
90/160	63/125	168	130	62	48	43	253	3 - 2	A
90/160	75/140	168	130	62	55	43	252	3 - 2 ½	A
110/180	63/125	188	154	72	48	57	267	4 - 2	A
110/180	75/140	188	154	72	55	57	268	4 - 2 ½	A
110/180	90/160	188	154	72	62	57	268	4 - 3	A
* 160/250	63/125	258	192	90	48	77	327	6 - 2	A
* 160/250	90/160	258	192	90	62	77	327	6 - 3	A
* 160/250	110/180	258	192	90	72	77	325	6 - 5	A
160/250	140/200	258	192	90	84	77	340	6 - 5	A A
225/315	63/125	324	355	110	48	220	412	8 - 2	A
225/315	90/160	324	355	110	62	220	412	8 - 3	A
225/315	110/180	324	355	110	72	220	412	8 - 4	A
225/315	140/200	324	355	110	84	220	412	8 - 5	A
225/315	160/250	324	355	110	90	220	396	8 - 6	A
160/250	63/125	258	192	90	48	77	221	6 - 1	-
160/250	90/160	258	192	90	62	77	235	6 - 3	-
160/250	110/180	258	192	90	72	77	245	6 - 5	-

COOL-FIT 4.0 Reducer, d32-d225



Model:

- Pre-insulated PE100 SDR11, metric
- Insulation made from GF HE foam
- Outer jacket impact resistant. Colour: black
- A: Electrofusion Fitting with integrated sealing lip, for a water and vapour tight sealing
- B: Spigot Fitting with free end (separate electrofusion fitting needed for joining)

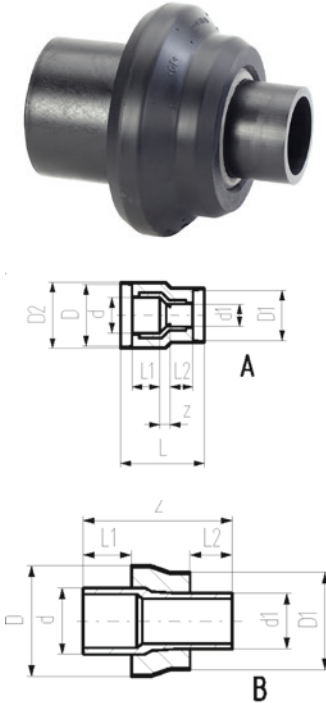

d/D (mm)	d1/D1 (mm)	PN (bar)	Code GF	Code Reece	Weight (kg)	D2 (mm)	L (mm)	L1 (mm)	L2 (mm)	z (mm)	Closest Inch (inch)	Type
40/110	32/90	16	738 903 206	1470393	0.250	117	143	40	36	17	1 ¼ - 1	A
50/110	32/90	16	738 903 209	1470394	0.280	117	151	44	36	21	1 ½ - 1	A
50/110	40/110	16	738 903 210	1470395	0.320	117	149	44	40	15	1 ½ - 1 ¼	A
63/125	32/90	16	738 903 212	1470396	0.217	132	160	48	36	26	2 - 1	A
63/125	40/110	16	738 903 213	1470397	0.232	132	159	48	40	21	2 - 1 ¼	A
63/125	50/110	16	738 903 214	1470398	0.243	132	159	48	44	17	2 - 1 ½	A
75/140	63/125	16	738 903 318	1470399	0.264	-	-	55	48	170	2 ½ - 2	B
90/160	63/125	16	738 903 322	1470400	0.387	-	-	62	48	190	3 - 2	B
90/160	75/140	16	738 903 323	1470401	0.416	-	-	62	55	189	3 - 2 ½	B
110/180	63/125	16	738 903 327	1470402	0.566	-	-	72	48	204	4 - 2	B
110/180	75/140	16	738 903 328	1470403	0.577	-	-	72	55	205	4 - 2 ½	B
110/180	90/160	16	738 903 329	1470404	0.644	-	-	72	62	205	4 - 3	B
160/252	63/125	16	738 903 347	1470405	1.298	-	-	90	48	244	6 - 2	B
160/250	90/160	16	738 903 349	1470406	1.323	-	-	90	62	244	6 - 3	B
160/250	110/180	16	738 903 350	1470407	1.362	-	-	90	72	242	6 - 4	B
160/250	140/200	16	738 903 351	-	1.664	-	-	90	84	257	6 - 5	B
225/315	63/125	16	738 903 364	1470408	2.960	-	-	110	48	295	8 - 2	B
225/315	90/160	16	738 903 366	1470409	3.018	-	-	110	62	295	8 - 3	B
225/315	110/180	16	738 903 367	1470410	3.079	-	-	110	72	295	8 - 4	B
225/315	140/200	16	738 904 368	1470599	3.172	-	-	110	84	296	8 - 5	B
225/315	160/250	16	738 903 369	1470411	3.550	-	-	110	90	279	8 - 6	B

COOL-FIT 4.0 Reducer, d250-d450



Model:

- Pre-insulated PE100 SDR 17 metric
- Insulation made from GF HE foam
- Outer jacket impact resistant. Colour: black
- B: Spigot Fitting with free end (separate electrofusion fitting needed for joining)

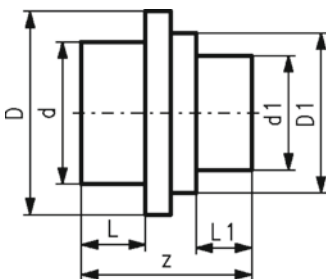

d/D (mm)	d1/D1 (mm)	PN	Code GF	Code Reece	Weight (kg)	L (mm)	L1 (mm)	z (mm)	Type
250/355	225/315	PN 10	738 903 825	1470510	2.800	123	110	332	B
280/400	225/315	PN 10	738 903 829	1470511	4.700	126	110	335	B
280/400	250/315	PN 10	738 903 830	1470512	5.100	133	110	365	B
315/450	225/315	PN 10	738 903 836	1470515	7.100	126	110	340	B
315/450	250/355	PN 10	738 903 837	1470513	7.400	133	123	365	B
315/450	280/400	PN 10	738 903 838	1470514	6.800	133	126	365	B
355/500	250/355	PN 10	738 903 844	1470516	8.200	148	123	390	B
355/500	280/400	PN 10	738 903 845	1470517	7.700	148	126	390	B
355/500	315/450	PN 10	738 903 846	1470518	8.300	148	133	390	B
400/560	280/400	PN 10	738 903 853	1470519	9.100	150	126	415	B
400/560	315/450	PN 10	738 903 854	1470520	11.400	150	133	420	B
400/560	355/500	PN 10	738 903 855	1470521	11.000	150	148	405	B
450/630	280/400	PN 10	738 903 862	1470522	13.200	165	126	390	B
450/630	315/450	PN 10	738 903 863	1470523	13.600	165	133	390	B
450/630	355/500	PN 10	738 903 864	1470524	13.700	165	148	393	B
450/630	400/560	PN 10	738 903 865	1470525	14.800	165	150	395	B

COOL-FIT 4.0 Installation fitting type 313, d32-d225



Model:

- Pre-insulated, PE100, SDR11, metric
- Insulation made from GF HE foam
- Impact resistant. Colour: black
- With threaded branch for sensors (i.e temperature, pressure)
- A: Electrofusion Fitting with integrated sealing lip, for a water and vapour tight sealing
- B: Spigot Fitting with free end (separate electrofusion fitting needed for joining)

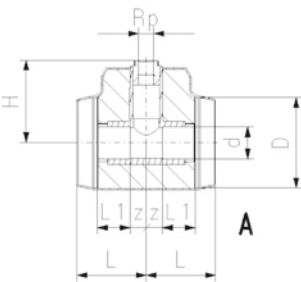

d/D (mm)	Rp (inch)	PN (bar)	Code GF	Code Reece	Weight (kg)	H (mm)	L (mm)	L1 (mm)	z (mm)	Type
32/90	1/2	16	738 313 608	1470412	0.169	95	79	36	18	A
40/110	1/2	16	738 313 609	1470413	0.267	105	87	40	22	A
40/110	3/4	16	738 313 659	1470414	0.269	108	87	40	22	A
50/110	1/2	16	738 313 610	1470415	0.354	107	94	44	25	A
50/110	3/4	16	738 313 660	1470416	0.356	110	94	44	25	A
63/125	1/2	16	738 313 611	1470417	0.537	120	103	48	30	A
63/125	3/4	16	738 313 661	1470418	0.539	123	103	48	30	A
75/140	1/2	16	738 313 612	1470419	0.773	127	116	55	36	A
75/140	3/4	16	738 313 662	1470420	0.774	130	116	55	36	A
90/160	1/2	16	738 313 613	1470421	1.164	139	130	62	43	A
90/160	3/4	16	738 313 663	1470422	1.165	142	130	62	43	A
110/180	1/2	16	738 313 614	1470423	1.944	151	154	72	57	A
110/180	3/4	16	738 313 664	1470424	1.944	154	154	72	57	A
160/250	1/2	16	738 313 617	1470425	2.496	134	165	90	330	B
160/250	3/4	16	738 313 667	1470426	2.489	134	165	90	330	B
225/315	1/2	16	738 313 620	1470427	5.155	166	185	110	370	B
225/315	3/4	16	738 313 670	1470428	5.146	169	185	110	370	B

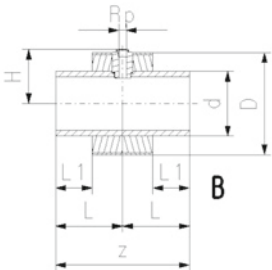

COOL-FIT 4.0 Transition T90° PE/Brass with male thread Rp

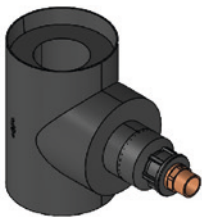

Model:

- Pre-insulated, PE100, SDR11, metric
- Insulation made from GF HE foam
- Impact resistant. Colour: black
- A: Electrofusion Fitting with integrated sealing lip, for water and vapour type sealing

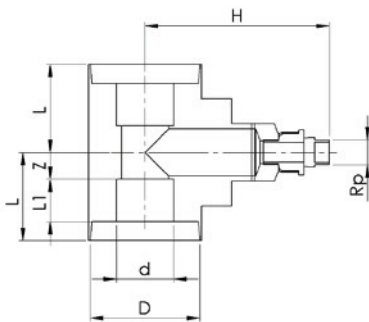

d (mm)	Rp (inch)	PN	Code GF	Code Reece	L (mm)	L1 (mm)	z (mm)	H (mm)	Closest Inch (inch)	Type
32/90	1	16	20006A439	1470673	79	36	18	190	1	A
40/110	1	16	20006A440	1470674	87	40	22	214	1 1/4	A
50/110	1	16	20006A441	1470675	94	44	25	216	1 1/2	A
63/125	3/4	16	20006A442	1470676	103	48	30	233	2	A
63/125	1	16	20006A443	1470677	103	48	30	233	2	A
75/140	3/4	16	20006A444	1470678	116	55	36	240	2 1/2	A
75/140	1	16	20006A445	1470679	116	55	36	240	2 1/2	A
90/160	1	16	20006A446	1470680	130	62	43	255	3	A
110/180	1	16	20006A447	1470681	154	72	57	265	4	A

COOL-FIT 4.0 Transition Fittings

COOL-FIT 4.0 Adaptor fitting PE/stainless steel with male thread R



Model:

- Spigot fitting PE100 SDR11, metric with free end
- Stainless steel 1.4404 / 316L with male thread R
- Gasket: O-ring EPDM
- Including Insulation made from NBR foam

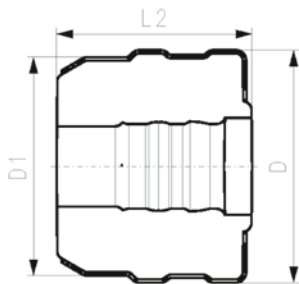
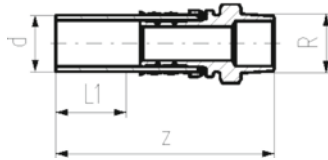

d (mm)	R (inch)	PN (bar)	Code GF	Code Reece	Weight (kg)	D (mm)	D1 (mm)	L1 (mm)	L2 (mm)	z (mm)
32	1/2	16	738 943 508	-	0.224	103	90	36	80	130
32	3/4	16	738 943 518	-	0.232	103	90	36	80	134
32	1	16	738 943 528	-	0.241	103	90	36	80	134
40	1 1/4	16	738 943 509	-	0.655	128	110	40	91	156
50	1 1/2	16	738 943 510	-	1.020	138	110	44	96	168
63	2	16	738 943 511	-	1.458	149	125	48	103	179

COOL-FIT 4.0 Adaptor fitting PE/stainless steel with male thread NPT



Model:

- Spigot fitting PE100 SDR11, ANSI with free end
- Stainless steel 1.4404 / 316L with male thread NPT
- Gasket: O-ring EPDM
- Including insulation half shells

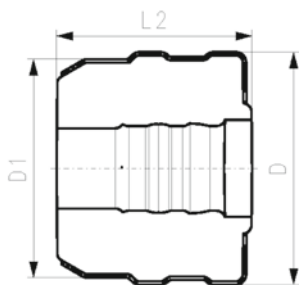
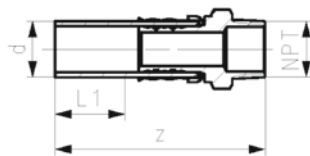

d (mm)	NPT (inch)	PN (bar)	Code GF	Code Reece	Weight (kg)	D (mm)	D1 (mm)	L1 (mm)	L2 (mm)	z (mm)
32	1/2	16	738 943 808	-	0.224	104	90	36	80	129
32	3/4	16	738 943 818	-	0.655	104	90	36	80	133
32	1	16	738 943 828	-	1.021	104	90	36	80	134
40	1 1/4	16	738 943 809	-	1.459	128	110	40	91	151
50	1 1/2	16	738 943 810	-	0.232	138	110	44	96	163
63	2	16	738 943 811	-	0.241	149	125	48	103	174

COOL-FIT 4.0 Adaptor fitting PE/stainless steel with female thread Rp



Model:

- Spigot fitting PE100 SDR11, metric with free end
- Stainless steel 1.4404 / 316L with female thread Rp
- Gasket: O-ring EPDM
- Including Insulation half shells

d	Rp	PN	Code	Code	Weight	D	D1	L1	L2	z
(mm)	(inch)	(bar)	GF	Reece	(kg)	(mm)	(mm)	(mm)	(mm)	(mm)
32	1/2	16	738 943 008	-	0.247	104	90	36	101	118
32	3/4	16	738 943 018	-	0.272	104	90	36	101	116
32	1	16	738 943 028	-	0.297	104	90	36	101	115
40	1 1/4	16	738 943 009	-	0.683	128	110	40	91	141
50	1 1/2	16	738 943 010	-	0.734	138	110	44	96	128
63	2	16	738 943 011	-	1.244	149	125	48	103	140

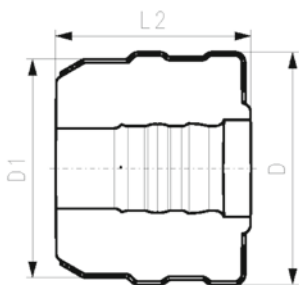
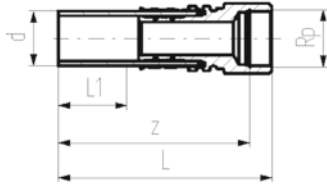

COOL-FIT 4.0 Adaptor fitting PE/stainless steel with female thread NPT



Model:

- Spigot fitting PE100 SDR11, ANSI with free end
- Stainless steel 1.4404 / 316L with female thread NPT
- Gasket: O-ring EPDM
- Including Insulation half shells

d	NPT	PN	Code	Code	Weight	D	D1	L1	L2	z
(mm)	(inch)	(bar)	GF	Reece	(kg)	(mm)	(mm)	(mm)	(mm)	(mm)
32	1/2	16	738 943 408	-	0.247	104	90	36	101	114
32	3/4	16	738 943 418	-	0.683	104	90	36	101	114
32	1	16	738 943 428	-	0.735	104	90	36	101	114
40	1 1/4	16	738 943 409	-	1.245	128	110	40	91	125
50	1 1/2	16	738 943 410	-	0.272	138	110	44	96	124
63	2	16	738 943 411	-	0.297	149	125	48	103	136

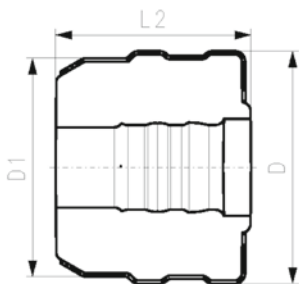
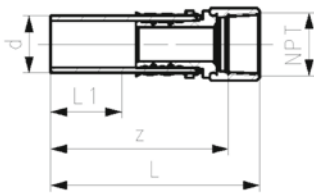



COOL-FIT 4.0 Adaptor fitting PE/stainless steel with loose union nut G

Model:

- Spigot fitting PE100 SDR11, metric with free end
- Stainless steel 1.4404 / 316L with loose union nut G
- Including flat seal EPDM
- Including insulation half shells

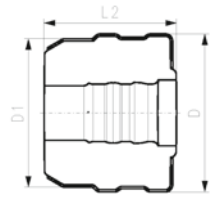
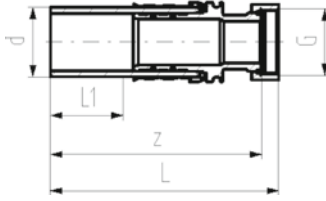

d (mm)	G (mm)	PN (bar)	GF Code	Code Reece	Weight (kg)	D (mm)	D1 (mm)	L (mm)	L1 (mm)	L2 (mm)	z (mm)
32	1/2"	16	738 943 308	1470438	0.250	104	90	133	36	101	126
32	3/4"	16	738 943 318	1470439	0.264	104	90	135	36	101	129
32	1"	16	738 943 328	1470440	0.296	104	90	135	36	101	129
40	1 1/4"	16	738 943 309	1470441	0.595	128	110	155	40	91	148
40	1 1/2"	16	738 943 319	1470442	0.655	128	110	157	40	91	148
50	1 1/2"	16	738 943 310	1470443	0.820	138	110	164	44	96	154
63	2"	16	738 943 311	1470444	1.307	149	125	186	48	103	170

COOL-FIT 4.0 Adaptor Union PE/ABS

Model:

- Union bush: ABS Solvent cement socket
- Union End: Spigot fitting PE100 SDR11, metric with free end
- Gasket: O-ring EPDM Nr. 748 410 008-014
- Union Nut: ABS
- Including insulation half shells

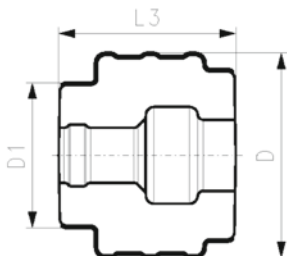
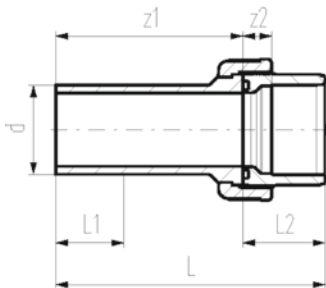

d (mm)	PN (bar)	Code GF	Code Reece	Weight (kg)	D (mm)	D1 (mm)	L (mm)	L1 (mm)	L2 (mm)	L3 (mm)	z1 (mm)	z2 (mm)
32	10	738 513 708	1470449	0.169	134	90	137	36	33	109	104	11
40	10	738 513 709	1470450	0.256	143	110	156	40	39	126	117	13
50	10	738 513 710	1470451	0.334	154	110	169	44	46	135	123	15
63	10	738 513 711	1470452	0.522	172	125	190	48	58	152	132	21
75	10	738 513 712	1470453	0.996	210	140	211	55	62	170	149	18
90	10	738 513 713	1470454	1.336	233	160	215	62	69	167	146	18
110	10	738 513 714	1470455	1.900	263	180	235	72	72	177	163	11



COOL-FIT 4.0 Union PE/PE

Model:

- Union Bush: Spigot fitting PE100 SDR11, metric with free end
- Union End: Spigot fitting PE100 SDR11, metric with free end
- Gasket: O-ring EPDM Nr. 748 410 008-014
- Union Nut: PEGF25
- Including insulation half shells

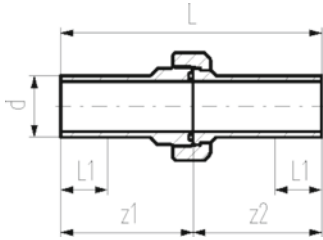

d (mm)	PN (bar)	Code GF	Code Reece	Weight (kg)	D (mm)	D1 (mm)	L (mm)	L1 (mm)	L2 (mm)	z1 (mm)	z2 (mm)
32	16	738 513 608	1470445	0.223	139	90	211	36	139	107	104
40	16	738 513 609	1470446	0.363	153	110	234	40	158	118	116
50	16	738 513 610	1470447	0.468	165	110	247	44	163	124	123
63	16	738 513 611	1470448	0.584	185	125	268	48	176	136	132

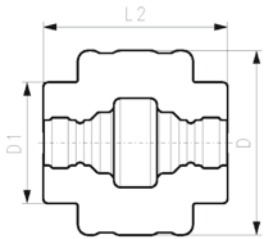

COOL-FIT 2.0 Adaptor Union PE/Stainless steel with male thread R

Model:

- Union Bush: Spigot fitting PE100 SDR11, metric with free end
- Union End: Stainless steel 1.4404 / 316L with male thread R
- Gasket: O-ring EPDM No. 748 410 008-011
- Union Nut: PEGF25
- Including Insulation made from NBR foam

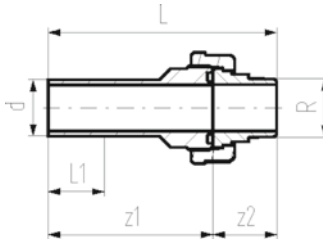

d (mm)	R (inch)	PN (bar)	Code GF	Code Reece	Weight (kg)	D (mm)	L (mm)	L1 (mm)	z1 (mm)	z2 (mm)
32	1	16	738 544 708	1470169	0.310	108	147	36	107	40
40	1 ¼	16	738 544 709	1470170	0.538	116	163	40	117	46
50	1 ½	16	738 544 710	1470171	0.660	126	172	44	124	48
63	2	16	738 544 711	1470172	1.073	139	191	48	136	55

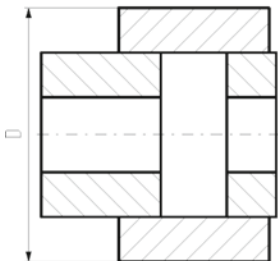



COOL-FIT 2.0 Adaptor Union PE/Stainless steel with female thread Rp

Model:

- Union Bush: Spigot fitting PE100 SDR11, metric with free end
- Union End: Stainless steel 1.4404 / 316L with female thread Rp
- Gasket: O-ring EPDM No. 748 410 008-011
- Union Nut: PEGF25
- Including Insulation made from NBR foam

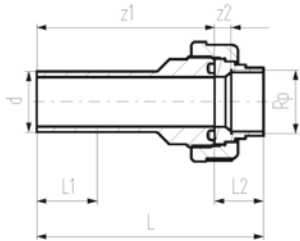

d (mm)	Rp (inch)	PN (bar)	Code GF	Code Reece	Weight (kg)	D (mm)	L (mm)	L1 (mm)	L2 (mm)	z1 (mm)	z2 (mm)
32	1	16	738 544 208	1470165	0.270	108	136	36	29	107	10
40	1 ¼	16	738 544 209	1470166	0.433	116	150	40	33	118	11
50	1 ½	16	738 544 210	1470167	0.587	126	158	44	34	124	13
63	2	16	738 544 211	1470168	0.883	139	175	48	39	136	14

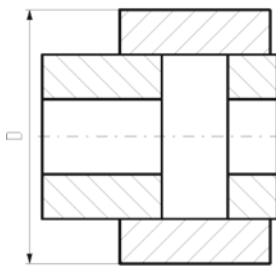

COOL-FIT 2.0/4.0 Adaptor Union PE/Stainless steel with male thread R



Model:

- Union Bush: Spigot fitting PE100 SDR11, metric with free end
- Union End: Stainless steel 1.4404 / 316L with male thread R
- Gasket: O-ring EPDM No. 748 410 008-011
- Union Nut: PEGF25

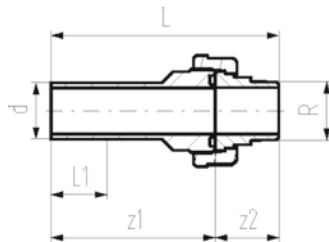

d (mm)	R (inch)	PN (bar)	Code GF	Code Reece	Weight (kg)	L (mm)	L1 (mm)	z1 (mm)	z2 (mm)
32	1	16	738 540 708	1470653	0.276	147	36	107	40
40	1 ¼	16	738 540 709	1470654	0.495	163	40	117	46
50	1 ½	16	738 540 710	1470655	0.606	172	44	124	48
63	2	16	738 540 711	1470656	1.000	191	48	136	55

COOL-FIT 2.0/4.0 Adaptor Union PE/Stainless steel with female thread Rp



Model:

- Union Bush: Spigot fitting PE100 SDR11, metric with free end
- Union End: Stainless steel 1.4404 / 316L with female thread Rp
- Gasket: O-ring EPDM No. 748 410 008-011
- Union Nut: PEGF25

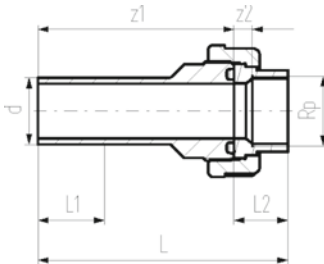

d (mm)	R (inch)	PN (bar)	Code GF	Code Reece	Weight (kg)	L (mm)	L1 (mm)	z1 (mm)	z2 (mm)
32	1	16	738 540 208	1470649	0.234	147	36	107	40
40	1¼	16	738 540 209	1470650	0.387	163	40	117	46
50	1½	16	738 540 210	1470651	0.530	172	44	124	48
63	2	16	738 540 211	1470652	0.807	191	48	136	55

COOL-FIT 2.0/4.0 Adaptor fitting PE/stainless steel with male thread R



Model:

- Spigot fitting PE100 SDR11, metric with free end
- Stainless steel 1.4404 / 316L with male thread R
- Gasket: O-ring EPDM

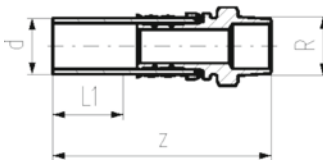

d (mm)	R (inch)	PN (bar)	Code GF	Code Reece	Weight (kg)	L1 (mm)	z (mm)
32	½	16	738 940 508	-	0.179	36	130
32	¾	16	738 940 518	-	0.187	36	134
32	1	16	738 940 528	-	0.196	36	134
40	1¼	16	738 940 509	-	0.572	40	156
50	1½	16	738 940 510	-	0.927	44	168
63	2	16	738 940 511	-	1.347	48	179

COOL-FIT 4.0 Adaptor fitting PE/stainless steel with male thread NPT



Model:

- Spigot fitting PE100 SDR11, ANSI with free end
- Stainless steel 1.4404 / 316L with male thread NPT
- Gasket: O-ring EPDM

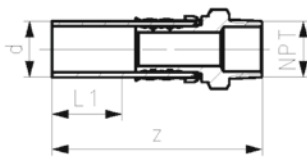

d (mm)	NPT (inch)	Rp (inch)	PN (bar)	Code GF	Code Reece	Weight (kg)	L (mm)	L1 (mm)	z (mm)
32	½	½	16	738 940 808	-	0.179	132	36	118
32	¾	¾	16	738 940 818	-	0.572	132	36	116
32	1	1	16	738 940 828	-	0.927	132	36	115
40	1¼	1¼	16	738 940 809	-	1.347	157	40	141
50	1½	1½	16	738 940 810	-	0.187	150	44	128
63	2	2	16	738 940 811	-	0.196	164	48	140

COOL-FIT 2.0/4.0 Adaptor fitting PE/stainless steel with female thread Rp



Model:

- Spigot fitting PE100 SDR11, metric with free end
- Stainless steel 1.4404 / 316L with female thread Rp
- Gasket: O-ring EPDM

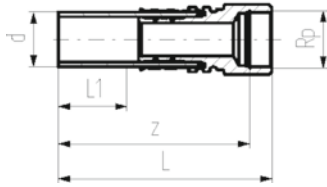

d (mm)	Rp (inch)	PN (bar)	Code GF	Code Reece	Weight (kg)	L (mm)	L1 (mm)	z (mm)
32	1/2	16	738 940 008	-	0.183	132	36	118
32	3/4	16	738 940 018	-	0.208	132	36	116
32	1	16	738 940 028	-	0.233	132	36	115
40	1 1/4	16	738 940 009	-	0.600	157	40	141
50	1 1/2	16	738 940 010	-	0.641	150	44	128
63	2	16	738 940 011	-	1.133	164	48	140

COOL-FIT 4.0 Adaptor fitting PE/stainless steel with female thread NPT



Model:

- Spigot fitting PE100 SDR11, ANSI with free end
- Stainless steel 1.4404 / 316L with female thread NPT
- Gasket: O-ring EPDM

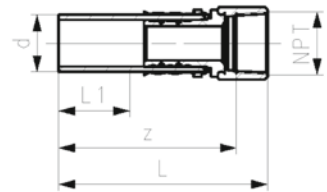

d (mm)	NPT (inch)	PN (bar)	Code GF	Code Reece	Weight (kg)	L (mm)	L1 (mm)	z (mm)
32	1/2	16	738 940 408	-	0.183	132	36	114
32	3/4	16	738 940 418	-	0.600	132	36	114
32	1	16	738 940 428	-	0.641	132	36	114
40	1 1/4	16	738 940 409	-	1.133	147	40	125
50	1 1/2	16	738 940 410	-	0.208	147	44	124
63	2	16	738 940 411	-	0.233	159	48	136

COOL-FIT 2.0/4.0 Adaptor fitting PE/stainless steel with loose union nut G



Model:

- Spigot fitting PE100 SDR11, metric with free end
- Stainless steel 1.4404 / 316L with loose union nut G
- Including flat seal EPDM

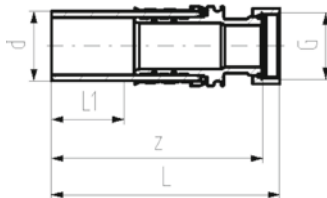

d (mm)	G (inch)	PN (bar)	Code GF	Code Reece	Weight (kg)	L (mm)	L1 (mm)	z (mm)
32	1/2	16	738 940 308	-	0.186	133	36	126
32	3/4	16	738 940 318	-	0.201	135	36	129
32	1	16	738 940 328	-	0.232	135	36	129
32	1 1/4	16	738 940 338	-	0.283	137	36	131
40	1 1/4	16	738 940 309	-	0.512	155	40	148
40	1 1/2	16	738 940 319	-	0.572	157	40	148
40	2	16	738 940 329	-	0.769	166	40	152
50	1 1/2	16	738 940 310	-	0.726	164	44	154
50	1 3/4	16	738 940 320	-	0.795	164	44	155
50	2	16	738 940 330	-	0.995	178	44	162
50	2 1/4	16	738 940 340	-	0.819	148	44	134
63	2	16	738 940 311	-	1.195	186	48	170
63	2 3/8	16	738 940 321	-	1.284	178	48	168
63	2 3/4	16	738 940 331	-	1.175	157	48	141

COOL-FIT 2.0/4.0 Adaptor fitting PE/Brass with male thread R



Model:

- Spigot fitting PE100 SDR11, metric with free end
- Brass CW617N with male thread R
- Gasket: O-ring EPDM

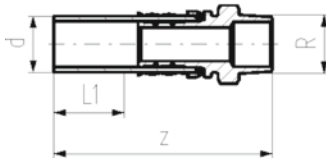

d (mm)	R (inch)	PN (bar)	Code GF	Code Reece	Weight (kg)	L1 (mm)	z (mm)
32	1/2	16	738 950 508	-	0.188	36	130
32	3/4	16	738 950 518	-	0.196	36	134
32	1	16	738 950 528	-	0.206	36	134
40	1 1/4		738 950 509	-	0.608	40	156
50	1 1/2	16	738 950 510	-	0.986	44	168
63	2	16	738 950 511	-	1.433	48	179

COOL-FIT 2.0/4.0 Adaptor fitting PE/Brass with female thread Rp



Model:

- Spigot fitting PE100 SDR11, metric with free end
- Brass CW617N with female thread Rp
- Gasket: O-ring EPDM

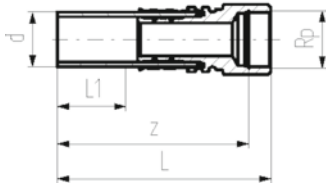

d (mm)	Rp (inch)	PN (bar)	Code GF	Code Reece	Weight (kg)	L (mm)	L1 (mm)	z (mm)
32	1/2	16	738 950 008	-	0.192	132	36	118
32	3/4	16	738 950 018	-	0.219	132	36	116
32	1	16	738 950 028	-	0.246	132	36	115
40	1 1/4	16	738 950 009	-	0.641	157	40	141
50	1 1/2	16	738 950 010	-	0.684	150	44	128
63	2	16	738 950 011	-	1.209	164	48	140

COOL-FIT 2.0/4.0 Adaptor fitting PE/Brass with loose union nut G



Model:

- Spigot fitting PE100 SDR11, metric with free end
- Brass CW617N with loose union nut G
- Including flat seal EPDM

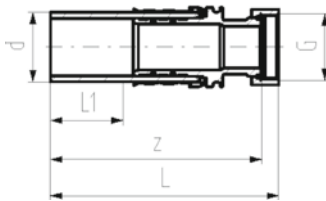

d (mm)	G (inch)	PN (bar)	Code GF	Code Reece	Weight (kg)	D (mm)	L (mm)	L1 (mm)	z (mm)
32	3/4	16	738 950 318	-	0.206	70	135	36	129
32	1	16	738 950 328	-	0.244	70	135	36	129
32	1 1/4	16	738 950 338	-	0.301	108	137	36	131
40	1 1/4	16	738 950 309	-	0.543	78	155	40	148
40	1 1/2	16	738 950 319	-	0.607	116	157	40	148
40	2	16	738 950 329	-	0.818	116	166	40	150
50	1 1/2	16	738 950 310	-	0.769	88	164	44	154
50	1 3/4	16	738 950 320	-	0.842	88	164	44	155
50	2	16	738 950 330	-	1.058	126	178	44	162
50	2 1/4	16	738 950 340	-	0.868	126	148	44	134
63	2	16	738 950 311	-	1.268	101	186	48	170
63	2 3/8	16	738 950 321	-	1.362	139	178	48	168
63	2 3/4	16	738 950 331	-	1.245	139	157	48	141

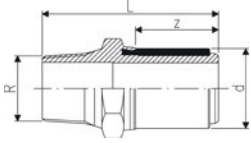

Transition adaptor PE/brass (CW617N) Male thread

- PE 100 SDR 11 (ISO S5)
- 16 bar

d (mm)	R (inch)	Code GF	Code Reece	Weight (kg)	L (mm)	z (mm)
20	1/2	720 920 706	1470295	0.133	75	33
25	3/4	720 920 707	1470296	0.182	76	33
32	1	720 920 708	1470037	0.257	80	35
32	1 1/4	720 920 718	1470298	0.370	82	35
32	1 1/2	720 920 728	1470299	0.437	82	35
40	1	720 920 719	1470042	0.358	84	39
40	1 1/4	720 920 709	1470301	0.405	86	39
40	1 1/2	720 920 729	1470302	0.454	86	39
50	1	720 920 720	1470043	0.505	88	43
50	1 1/4	720 920 730	1470304	0.539	90	43
50	1 1/2	720 920 710	1470305	0.514	90	43
63	1 1/4	720 920 721	1470306	0.739	94	47
63	1 1/2	720 920 731	1470048	0.709	94	47
63	2	720 920 711	1470040	0.762	98	47

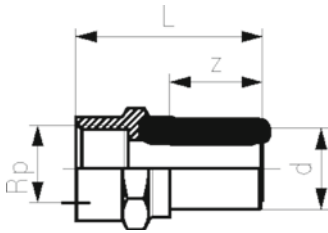
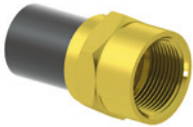

Transition adaptor PE/brass (CW617N) Female thread

- PE 100 SDR 11 (ISO S5)
- 16 bar

d (mm)	Rp (inch)	Code GF	Code Reece	Weight (kg)	L (mm)	z (mm)
32	1	720 920 208	1470309	0.250	71	35
40	1 1/4	720 920 209	1470310	0.386	77	39
50	1 1/2	720 920 210	1470311	0.520	81	43
63	1	720 920 221	1470312	0.780	83	47
63	1 1/4	720 920 231	-	1.062	85	47
63	1 1/2	720 920 241	1470313	0.740	85	47
63	2	720 920 211	1470314	0.729	89	47

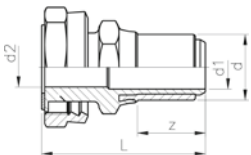

Transition adaptor PE/brass Loose nut (CW617N)

- PE 100 SDR 11 (ISO S5)
- 16 bar
- Incl. flat gasket for water applications (KTW / WRAS approved)

d (mm)	G (inch)	Code GF	Code Reece	Weight (kg)	d2 (mm)	L (mm)	z (mm)
25	3/4	720 920 007	1470023	0.152	15	68	32
32	1	720 920 008	1470316	0.235	20	72	34
32	1 1/4	720 920 018	1470317	0.356	22	76	34
50	1 1/2	720 920 010	1470318	0.584	29	87	42
63	1	720 920 021	1470028	0.804	20	87	46
63	2	720 920 011	1470026	1.018	36	95	46



**Transition adaptor PE/steel (stainless 1.4305)
Male thread**

- PE 100 SDR 11 (ISO S5)
- 16 bar

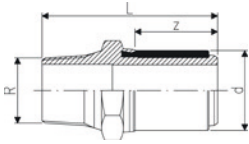

d (mm)	R (inch)	Code GF	Code Reece	Weight (kg)	L (mm)	z (mm)
20	1/2	724 920 706	1470321	0.120	75	33
25	3/4	724 920 707	1470322	0.179	76	33
32	1	724 920 708	1470057	0.244	80	35
40	1 1/4	724 920 709	1470324	0.380	86	39
50	1 1/2	724 920 710	1470326	0.478	90	43
63	1 1/2	724 920 721	1470327	0.653	98	47
63	2	724 920 711	1470060	0.722	98	47



**Transition adaptor PE/steel (stainless 1.4305)
Female thread**

- PE 100 SDR 11 (ISO S5)
- 16 bar

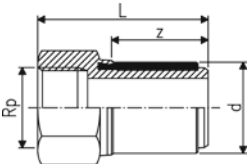

d (mm)	Rp (inch)	Code GF	Code Reece	Weight (kg)	L (mm)	z (mm)
20	1/2	724 920 206	1470329	0.128	65	33
25	3/4	724 920 207	1470330	0.181	66	33
32	1	724 920 208	1470331	0.237	71	35
40	1 1/4	724 920 209	1470332	0.373	77	39
50	1 1/2	724 920 210	1470333	0.527	81	43
63	2	724 920 211	1470334	0.733	89	47

**Transition Adaptor
PE/brass (CW612N) Male thread**

- PE100 SDR11
- 16 bar

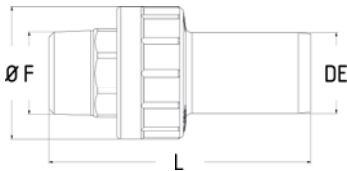

d (mm)	Rp (inch)	Code GF	Code Reece	Weight (kg)	L (mm)	A (mm)
32	1"	200 064 938	-	0.25	105	56
32	1 1/4"	200 064 939	-	0.38	155	56
40	1"	200 064 940	-	0.40	155	56
40	1 1/4"	200 064 941	-	0.40	120	56
40	1 1/2"	200 064 942	-	0.48	125	56
50	1"	200 064 943	-	0.45	115	57
50	1 1/2"	200 064 944	-	0.52	125	63
50	2"	200 064 945	-	0.70	130	57
63	1 1/2"	200 064 946	-	0.62	135	63
63	2"	200 064 947	-	0.73	140	63
75	2"	200 064 948	-	0.80	145	70
75	2 1/2"	200 064 949	-	1.20	155	70
90	3"	200 064 950	-	1.60	170	78
110	4"	200 064 951	-	2.90	200	87



Transition Adapter PE/Brass (CW612N) Female Thread

- PE100 SDR11
- 16 bar



d (mm)	Rp (inch)	Code GF	Code Reece	Weight (kg)	L (mm)	A (mm)
32	1"	200 064 952	-	0.20	90	47
40	1"	200 064 953	-	0.25	90	56
40	1 1/4"	200 064 954	-	0.30	100	56
40	1 1/2"	200 064 955	-	0.32	100	56
50	1"	200 064 956	-	0.32	100	57
50	1 1/2"	200 064 957	-	0.35	100	57
50	2"	200 064 958	-	0.52	115	57
63	1 1/2"	200 064 959	-	0.45	115	63
63	2"	200 064 960	-	0.58	120	63
75	2 1/2"	200 064 961	-	0.75	130	70
90	3"	200 064 962	-	1.00	145	78
110	4"	200 064 963	-	1.90	160	87



Transition Adapter PE/SS (grade AISI 316) Male Thread

- PE100 SDR11
- 16 bar

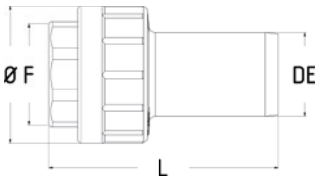

d (mm)	Rp (inch)	Code GF	Code Reece	Weight (kg)	L (mm)	A (mm)
32	1"	200 064 964	-	0.25	105	47
40	1 1/4"	200 064 965	-	0.40	120	56
40	1 1/2"	200 064 966	-	0.48	125	56
50	1 1/2"	200 064 967	-	0.52	125	57
50	2"	200 064 968	-	0.70	130	57
63	1 1/2"	200 064 969	-	0.62	135	63
63	2"	200 064 970	-	0.73	140	63
75	2"	200 064 971	-	0.80	145	70
75	2 1/2"	200 064 972	-	1.20	155	70
90	3"	200 064 973	-	1.60	170	78
110	4"	200 064 974	-	2.90	200	87



Transition Adapter PE/SS (grade AISI 316) Female Thread

- PE100 SDR11
- 16 bar

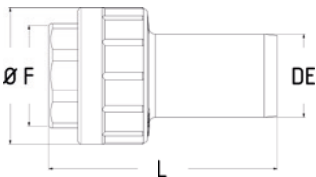

d (mm)	Rp (inch)	Code GF	Code Reece	Weight (kg)	L (mm)	A (mm)
32	1"	200 064 975	-	0.20	90	47
40	1 1/4"	200 064 976	-	0.30	100	56
40	1 1/2"	200 064 977	-	0.32	100	56
50	1 1/2"	200 064 978	-	0.35	100	57
50	2"	200 064 979	-	0.52	115	57
63	1 1/2"	200 064 980	-	0.45	115	63
63	2"	200 064 981	-	0.58	120	63
75	2 1/2"	200 064 982	-	0.75	130	70
90	3"	200 064 983	-	1.00	145	78
110	4"	200 064 984	-	1.90	160	87

Flanged Connections

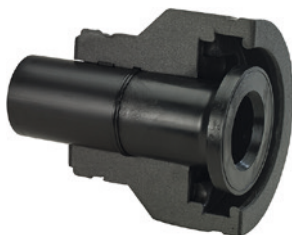

COOL-FIT 2.0/4.0 Flange Adaptor

- PE100 SDR 11 PN16, metric
- Suitable for flange connections to metric (from d110 also to ANSI/ASME B16.5)
- Gasket: Profile flange gasket NBR No. 45 44 07, EPDM No. 48 44 07
- Type 1 without chamfer, Type 2 with chamfer
- Separate Fittings Type A needed for joining

Model:

Backing ring and gasket not included

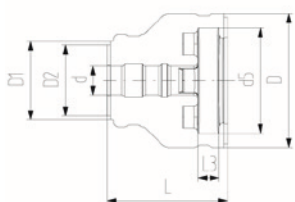
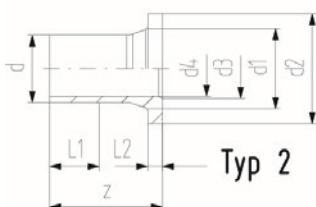
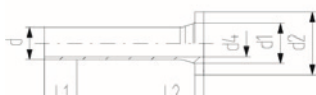

d (mm)	DN (mm)	PN (bar)	Code GF	Code Reece	Weight (kg)
32	25	16	738 710 008	1470173	0.051
40	32	16	738 710 009	1470174	0.075
50	40	16	738 710 010	1470175	0.900
63	50	16	738 710 011	1470176	0.173
75	65	16	738 710 012	1470177	1.210
90	80	16	738 710 013	1470178	1.193
110	100	16	738 710 014	1470179	1.574
140	125	16	738 710 016	1470180	2.412
160	150	16	738 710 017	1470458	1.748
225	200	16	738 710 020	1470459	10.440

d (mm)	DN (mm)	D (mm)	D1 (mm)	D2 (mm)	L (mm)	L1 (mm)	L2 (mm)	L3 (mm)	z (mm)	d1 (mm)	d2 (mm)	d3 (mm)	d4 (mm)	d5 (mm)	Type
32	25	135	90	75	162	36	10	26	190	40	68	-	26	121	1
40	32	170	110	90	165	40	11	28	197	50	78	-	32	146	1
50	40	180	110	90	178	44	12	30	214	61	88	-	40	156	1
63	50	200	125	110	230	48	14	32	270	75	102	-	51	171	1
75	65	220	140	125	232	55	16	34	279	89	122	-	61	191	2
90	80	240	160	140	245	62	17	35	299	105	138	78	73	206	2
110	100	270	180	160	254	72	18	36	320	125	158	100	90	235	2
140	125	300	225	200	299	84	25	38	383	155	188	127	127	256	2
160	150	358	259	-	332	90	25	34	412	174	213	151	131	295	2
225	200	423	325	-	383	110	32	37	462	233	268	209	184	354	2

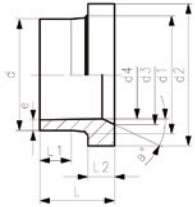
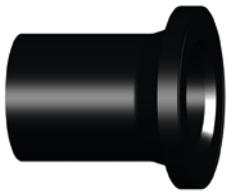

Un-insulated Flange Adaptor

- PE100 SDR 11, metric
- Suitable for flange connections to metric (from d110 also to ANSI/ASME B16.5)
- Gasket: Profile flange gasket NBR No. 45 44 07, EPDM No. 48 44 07

d (mm)	DN (mm)	PN (bar)	Code GF	Code Reece	Weight (kg)
32	25	16	753 800 008	1407423	0.056
40	32	16	753 800 009	1407424	0.081
50	40	16	753 800 010	1407425	0.119
63	50	16	753 800 011	1422168	0.187
75	65	16	753 800 012	1407427	0.314
90	80	16	753 800 013	1422169	0.471
110	100	16	753 800 014	1407429	0.706
140	125	16	753 800 016	1422181	1.348
160	150	16	753 800 017	1422172	0.314
180	150	16	753 800 018	1422173	0.471
225	200	16	753 800 020	1402618	0.706
250	250	16	753 800 021	1402514	1.348
280	250	16	753 800 022	1402868	0.706
315	300	16	753 800 023	1422178	1.348
355	350	16	753 800 224	1470533	0.314
400	400	16	753 800 225	-	0.471
450	500	16	753 800 226	1470534	0.706

d (mm)	DN (mm)	d1 (mm)	d2 (mm)	d3 (mm)	d4 (mm)	L (mm)	L1 (mm)	L2 (mm)	e (mm)
32	25	40	68	-	26	91.5	61.0	10	3.0
40	32	50	78	-	32	94.5	61.5	11	3.7
50	40	61	88	-	40	90.0	62.0	12	4.6
63	50	75	102	-	51	98.0	69.0	14	5.8
75	65	89	122	66	61	125.0	89.0	16	6.8
90	80	105	138	78	73	140.0	103.0	17	8.2
110	100	125	158	100	90	160.0	114.0	18	10.0
140	125	155	188	127	114	200.0	147.0	25	12.7
160	150	175	212	151	130	200.0	147.0	25	14.6
180	150	180	212	158	147	200.0	170.0	30	16.4
225	200	235	268	210	184	200.0	138.0	32	20.5
250	250	285	320	252	202	220.0	129.0	35	22.7
280	250	291	320	265	229	231.0	144.0	35	25.4
315	300	335	370	300	257	239.0	158.0	35	28.6
355	350	373	430	342	284	267.0	170.0	40	32.0
400	400	427	482	387	320	292.0	185.0	46	36.0
450	500	514	585	400	360	330.0	205.0	60	41.0

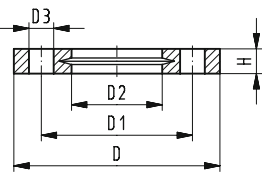

Backing Rings ANSI Class 150

- AL: Number of holes
- Material: ASTM A105 / Zinc-coated AS NZS 4680-2006

d (mm)	Inch Size (inch)	PN (bar)	GF Code (Galvanised)	GF Code (Stainless Steel)	Weight (kg)	D (mm)	D1 (mm)	D2 (mm)	D3 (mm)	H (mm)	AL	SC
32	1	16	200 059 784	200 059 907	0.78	108	79.5	42	16	14.2	4	M14
40	1 1/4	16	200 059 785	200 059 908	0.98	117	89.0	51	16	15.7	4	M14
50	1 1/2	16	200 059 786	200 059 909	1.23	127	98.5	62	16	17.5	4	M14
63	2	16	200 059 787	200 059 910	1.82	152	120.5	78	20	19.0	4	M18
75	2 1/2	16	200 059 788	200 059 911	3.00	178	139.5	92	20	22.3	4	M18
90	3	16	200 059 789	200 059 912	3.39	191	152.0	110	20	23.9	4	M18
110	4	16	200 059 790	200 059 913	4.88	229	190.5	128	20	23.9	8	M18
125	5	16	200 059 791	200 059 914	6.10	254	216.0	140	22	23.9	8	M18
140	5	16	200 059 792	200 059 915	5.26	254	216.0	158	22	23.9	8	M20
160	6	16	200 059 793	200 059 916	6.68	279	241.0	178	22	25.4	8	M20
180	6	16	200 059 794	200 059 917	5.68	279	241.0	195	22	25.4	8	M20
200	8	16	200 059 795	200 059 918	10.34	343	298.5	235	22	28.4	8	M20
225	8	16	200 059 796	200 059 919	10.09	343	298.5	238	22	28.4	8	M20
250	10	16	200 059 797	200 059 920	13.86	406	362.0	288	26	30.2	12	M24
280	10	16	200 059 798	200 059 921	13.20	406	362.0	294	26	30.2	12	M24
315	12	16	200 059 799	200 059 922	20.81	482	432.0	345	26	31.8	12	M24
355	14	16	200 059 800	200 059 923	28.70	533	476.0	376	30	35.0	12	M27
400	16	16	200 059 801	200 059 924	36.59	600	540.0	430	30	36.6	16	M27
450	18	16	200 059 802	200 064 776	29.19	635	578.0	516	33	39.6	16	M30

Backing Rings AS4087 PN16

- AL: Number of holes
- Material: ASTM A105 / Zinc-coated AS NZS 4680-2006

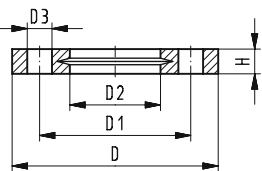

d (mm)	DN (mm)	PN (bar)	GF Code (Galvanised)	GF Code (Stainless Steel)	Weight (kg)	D (mm)	D1 (mm)	D2 (mm)	D3 (mm)	H (mm)	AL	SC
32	25	16	200 059 784	200 059 879	0.53	115	83	42	14	8	4	M12
40	32	16	200 059 785	200 059 880	0.55	120	87	51	14	8	4	M12
50	40	16	200 059 786	200 059 881	0.76	135	98	62	14	9	4	M12
63	50	16	200 059 787	200 059 882	0.94	150	114	78	18	10	4	M16
75	65	16	200 059 788	200 059 883	1.09	165	127	92	18	10	4	M16
90	80	16	200 059 789	200 059 884	1.43	185	146	110	18	11	4	M16
110	100	16	200 059 790	200 064 101	2.31	215	178	128	18	13	4	M16
125	125	16	200 059 791	200 064 102	2.05	215	178	135	18	13	4	M16
140	125	16	200 059 792	200 064 103	3.03	255	210	158	18	13	8	M16
160	150	16	200 059 793	200 064 104	3.57	280	235	178	18	13	8	M16
180	150	16	200 059 794	200 064 105	3.06	280	235	188	18	13	8	M16
200	200	16	200 059 795	200 064 106	6.43	335	292	235	18	19	8	M16
225	200	16	200 059 796	200 064 107	9.07	370	324	240	18	19	8	M16
250	250	16	200 059 797	200 064 108	9.13	405	356	288	22	19	8	M20
280	250	16	200 059 798	200 064 109	10.04	405	356	294	22	23	8	M20
315	300	16	200 059 799	200 064 110	11.76	455	406	338	22	23	12	M20
355	350	16	200 059 800	200 064 111	23.54	525	470	376	26	30	12	M24
400	400	16	200 059 801	200 064 112	26.46	580	521	430	26	30	12	M24
450	450	16	200 059 802	200 064 113	25.24	640	584	516	26	30	12	M24



Backing Rings Table E

- AL: Number of holes
- Material: ASTM A105 / Zinc-coated AS NZS 4680-2006

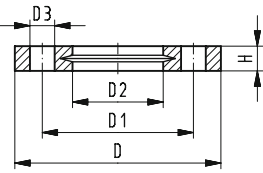

d (mm)	DN (mm)	PN (bar)	GF Code (Galvanised)	GF Code (Stainless Steel)	Weight (kg)	D (mm)	D1 (mm)	D2 (mm)	D3 (mm)	H (mm)	AL	SC
32	25	14	200 059 728	200 059 879	0.53	115	83	42	14	8	4	M12
40	32	14	200 059 729	200 059 880	0.55	120	87	51	14	8	4	M12
50	40	14	200 059 730	200 059 881	0.76	135	98	62	14	9	4	M12
63	50	14	200 059 731	200 059 882	0.94	150	114	78	18	10	4	M16
75	65	14	200 059 732	200 059 883	1.09	165	127	92	18	10	4	M16
90	80	14	200 059 733	200 059 884	1.43	185	146	110	18	11	4	M16
110	100	14	200 059 762	200 059 885	2.20	215	178	128	18	13	8	M16
125	100	14	200 059 845	200 059 886	2.05	215	178	135	18	13	8	M16
140	125	14	200 059 765	200 059 888	3.26	255	210	158	18	14	8	M16
160	150	14	200 059 766	200 059 889	4.53	280	235	178	22	17	8	M20
180	150	14	200 059 767	200 059 890	3.86	280	235	195	22	17	8	M20
200	200	14	200 059 768	200 059 891	6.28	335	292	235	22	19	8	M20
225	200	14	200 059 769	200 059 892	6.11	335	292	238	22	19	8	M20
250	250	14	200 059 770	200 059 893	10.14	405	356	290	22	22	12	M20
280	250	14	200 059 771	200 059 894	9.34	405	356	300	22	22	12	M20
315	300	14	200 059 772	200 059 895	13.17	455	406	338	26	25	12	M24
355	350	14	200 059 773	200 059 896	22.75	525	470	376	26	29	12	M24
400	400	14	200 059 774	200 059 897	28.54	580	521	430	26	32	12	M24
450	450	14	200 059 775	200 059 898	28.85	640	584	516	26	35	16	M24

Profile Flange Gasket, metric EPDM

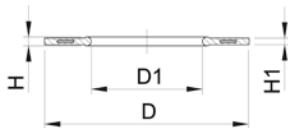

Model:

- For all metric GF Flange Adaptors
- Hardness: 70° Shore EPDM, 75° Shore FKM
- EPDM: approved acc. to DVGW Water W 270, KTW recommendation
- Centring on the inner diameter of the screw crown
- Material steel insert: carbon steel
- Rubber-steel body combined with rubber profile cord ring up to d630
- Rubber-steel body ideal for big dimensions (d710 - d1000)

di FA are the suitable inner diameters of flanges adaptors

d (mm)	PN (mm)	DN (bar)	EPDM Code	Code Reece	Weight (kg)	D (mm)	D1 (mm)	di FA (mm)	H (mm)	H1 (mm)
32	16	25	748 440 708	-	0.019	71	28	18 - 28	4	3
40	16	32	748 440 709	-	0.026	82	40	30 - 40	4	3
50	16	40	748 440 710	-	0.039	92	46	36 - 46	4	3
63	16	50	748 440 711	-	0.050	107	58	48 - 58	5	4
75	16	65	748 440 712	1470535	0.082	127	69	59 - 69	5	4
90	16	80	748 440 713	1470536	0.083	142	84	73 - 84	5	4
110	16	100	748 440 714	-	0.127	162	104	94 - 104	6	5
125	16	100	748 440 715	-	0.105	162	123	113 - 123	6	5
140	16	125	748 440 716	-	0.173	192	137	127 - 137	6	5
160 - 180	16	150	748 440 717	1470537	0.207	218	160	150 - 160	8	6
200	16	200	748 440 719	-	0.263	273	203	192 - 203	8	6
225	16	200	748 440 720	1470538	0.255	273	220	207 - 220	8	6
250	16	250	748 440 721	1470539	0.462	328	252	238 - 252	8	6
280	16	250	748 440 722	-	0.323	328	274	264 - 274	8	6
315	16	300	748 440 723	1470540	0.549	378	306	296 - 306	8	6
355	16	350	748 440 724	1470541	0.870	438	355	340 - 355	10	7
400	16	400	748 440 725	-	1.088	489	400	385 - 400	10	7
450	10	500	748 440 726	1470542	0.718	594	403	393 - 403	10	7
500	10	500	748 440 727	-	0.718	594	447	437 - 447	10	7
560	10	600	748 440 728	-	0.923	695	494	484 - 494	10	7
630	10	600	748 440 729	-	0.923	695	555	545 - 555	10	7

COOL-FIT 4.0 Flexible Hoses

COOL-FIT 4.0 Flex hose



Model:

- EPDM flexible hose with stainless steel protection
- Adaptors stainless steel 1.4404 / 316L
- Pre-Insulation made from EPDM foam with outer jacket impact resistant and tearproof
- With loose union nut G on one end and male thread GA on the other

Note:

d63 available as of beginning 2021

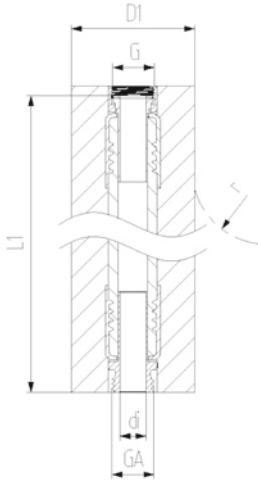

d (mm)	DN (mm)	G/GA (inch)	PN (bar)	Code GF	Code Reece	L1 (mm)	di (mm)	D1 (mm)	r (mm)
20	15	1/2"	10	738 923 206	1470664	1000	15	72	119
25	20	3/4"	10	738 923 207	1470665	1000	19	82	156
32	25	1"	10	738 923 208	1470666	1000	25	92	192
40	32	1 1/4"	8	738 923 209	1470667	1500	32	95	252
50	40	1 1/2"	6	738 923 210	1470668	2000	38	110	312
63	50	2"	6	738 923 211	1470669	2000	52	123	372

COOL-FIT 4.0 Valves



COOL-FIT 4.0 Ball valve type 546, hand-operated

Model:

- Material: ABS with spigot PE100 SDR11, metric
- Ball seals PTFE
- Integrated stainless steel mounting inserts
- Including insulation half shells
- Separate Fittings type A needed for joining

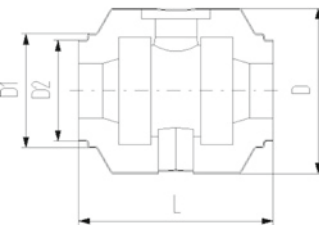
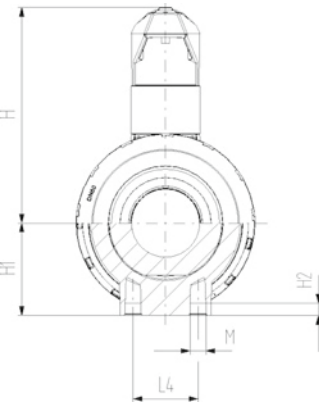
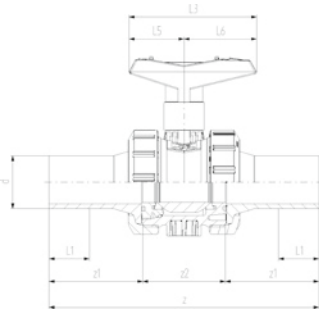

d (mm)	DN (mm)	PN (bar)	kv-value ($\Delta p=1$ bar) (l/min)	GF Code	Reece Code	Weight (kg)
32	25	10	700	138 546 108	1470460	0.542
40	32	10	1000	138 546 109	1470461	0.887
50	40	10	1600	138 546 110	1470462	1.165
63	50	10	3100	138 546 111	1470463	2.100
75	65	10	5000	138 546 112	1470464	5.125
90	80	10	7000	138 546 113	1470465	7.173

d (mm)	DN (mm)	D (mm)	D1 (mm)	D2 (mm)	L (mm)	L1 (mm)	L3 (mm)	H (mm)	H1 (mm)	H2 (mm)	z (mm)	z1 (mm)	z2 (mm)	Closest Inch (inch)
32	25	135	97	82	152	36	97	98	36	12	223	76	76	1
40	32	157	117	97	170	40	128	119	44	15	249	82	82	1 ¼
50	40	169	117	97	184	44	128	125	51	15	271	91	91	1 ½
63	50	204	132	117	227	48	152	150	64	15	321	110	110	2
75	65	235	147	132	276	55	270	194	85	15	386	125	125	2 ½
90	80	255	168	147	297	62	270	200	105	15	421	140	140	3

COOL-FIT 4.0 Ball valve type 179, electric



Model:

- Material: ABS with spigot PE100 SDR11, metric
- Ball seals PTFE
- Integrated stainless steel mounting inserts
- Voltage 100-230V, 50-60Hz
- Factory set control range 90°
- Heating element, position feedback (Open/Close/ Middle)
- Including insulation half shells
- Separate Fittings type A needed for joining

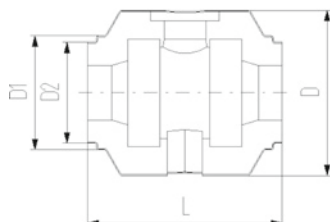
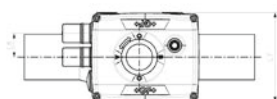
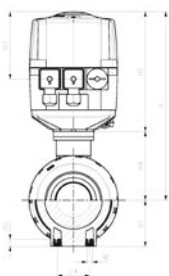
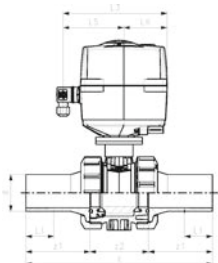

d (mm)	DN (mm)	PN (bar)	kv-value ($\Delta p=1$ bar)	GF Code	Reece Code	Weight (kg)
32	25	10	700	138 546 208	1470466	2.838
40	32	10	1000	138 546 209	1470467	3.174
50	40	10	1600	138 546 210	1470468	3.452
63	50	10	3100	138 546 211	1470469	4.475
75	65	10	5000	138 546 212	1470470	7.156
90	80	10	7000	138 546 213	1470471	13.000

d (mm)	DN (mm)	D (mm)	D1 (mm)	D2 (mm)	L (mm)	L1 (mm)	L3 (mm)	L4 (mm)	H (mm)	H1 (mm)	H2 (mm)	z (mm)	z1 (mm)	z2 (mm)	M
32	25	135	97	82	152	36	190	25	228	36	12	223	76	71	M6
40	32	157	117	97	170	40	190	45	240	44	15	249	82	85	M8
50	40	169	117	97	184	44	190	45	246	51	15	271	91	89	M8
63	50	204	132	117	227	48	190	45	263	64	15	321	110	101	M8
75	65	235	147	132	276	55	190	70	322	85	15	386	125	136	M8
90	80	255	168	147	297	62	190	70	357	105	15	421	140	141	M8

d (mm)	DN (mm)	Closest Inch (inch)
32	25	1
40	32	1¼
50	40	1½
63	50	2
75	65	1½
90	80	3



COOL-FIT 4.0 Butterfly valve kit type 567, hand-operated

Model:

- Material: ABS with spigot PE100 SDR11, metric
- Including flange adaptors, backing flanges PP-Steel, bolts and insulation half shells
- Separate Fittings type A needed for joining

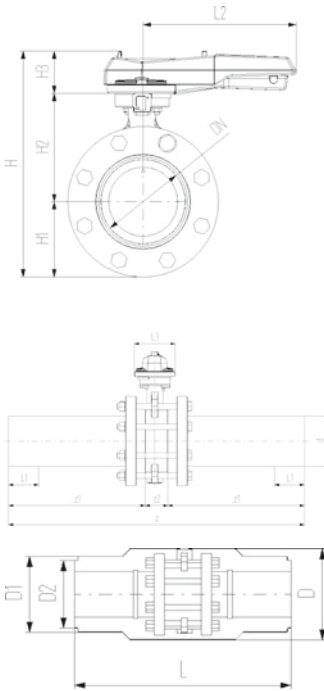

d (mm)	DN (mm)	PN (bar)	kv-value ($\Delta p=1$ bar) (l/min)	GF Code	Reece Code	Weight (kg)
110	100	10	6500	138 567 114	1470472	8.950
160	150	10	16600	138 567 117	1470473	17.975
225	200	10	39600	138 567 120	1470474	28.316

d (mm)	DN (mm)	D (mm)	D1 (mm)	D2 (mm)	L (mm)	L1 (mm)	L2 (mm)	L3 (mm)	H (mm)	H1 (mm)	H2 (mm)	H3 (mm)	z (mm)	z1 (mm)	z2 (mm)
110	100	310	188	168	556	72	255	106	325	104	167	55	696	320	56
160	150	358	259	-	720	90	255	115	143	143	203	55	895	412	72
225	200	409	325	-	776	110	408	149	465	170	210	85	996	462	73

d (mm)	DN (mm)	Closest Inch (inch)
110	100	4
160	150	5
225	200	8

COOL-FIT 4.0 Butterfly valve kit type 145, electric

Model:

- Material: ABS with spigot PE100 SDR11, metric
- Voltage 100-230V, 50-60Hz
- Factory set control range 90°
- Heating element, position feedback (Open/Close/ Middle)
- Including flange adaptors, backing flanges PP-Steel, bolts and insulation half shells
- Separate Fittings type A needed for joining

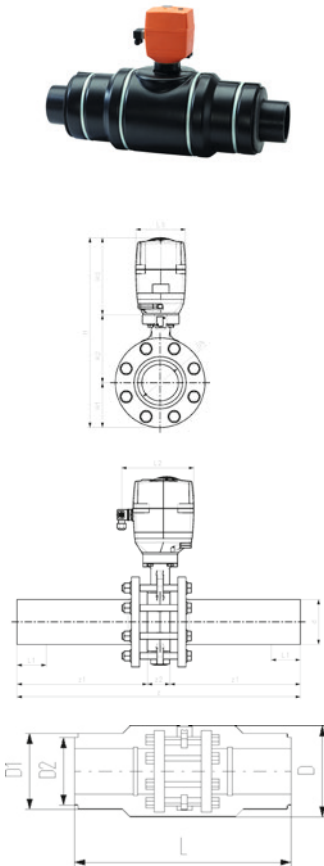

d (mm)	DN (mm)	PN (bar)	kv-value ($\Delta p=1$ bar) (l/min)	GF Code	Reece Code	Weight (kg)
110	100	10	6500	138 567 214	1470628	13.320
160	150	10	16500	138 567 217	1470629	22.346
225	200	10	39600	138 567 220	1470630	36.037

d (mm)	DN (mm)	D (mm)	D1 (mm)	D2 (mm)	L (mm)	L1 (mm)	L2 (mm)	L3 (mm)	H (mm)	H1 (mm)	H2 (mm)	H3 (mm)	z (mm)	z1 (mm)	z2 (mm)
110	100	310	188	168	552	72	179	122	460	104	167	190	696	320	56
160	150	358	259	-	720	90	179	122	535	143	203	190	895	412	72
225	200	409	325	-	776	110	179	122	580	170	210	200	996	462	73

d (mm)	DN (mm)	Closest Inch (inch)
110	100	4
160	150	5
225	200	8

COOL-FIT 4.0 Accessories



COOL-FIT 4.0 Assembly Aid-Kit Type B

Model:

- For simplified mounting of COOL-FIT 4.0 Fitting on COOL-FIT 4.0 Pipe

d (mm)	D (mm)	GF Code	Code Reece	Weight (kg)	Pieces/Kit
32	90	799 738 511	1470620	0.384	6
40 - 50	110	799 738 512	1470621	0.456	6
63	125	799 738 513	1470622	0.504	6
75	125	799 738 514	1470623	0.564	6
90	160	799 738 515	1470624	0.636	6
110	180	799 738 516	1470549	0.708	6
160	250	799 738 519	1470550	0.620	4
225	315	799 738 522	1470551	0.760	4

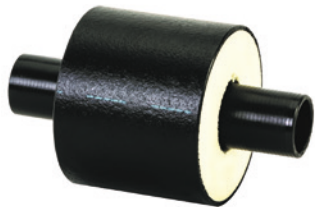

COOL-FIT 4.0 Barrel nipple with insulation, d32-d225

Model:

- Pre-insulated PE100 SDR11/17 metric
- Insulation made from GF HE foam
- Impact resistant. Color: black
- For short connections between COOL-FIT 4.0 Fittings Typ A

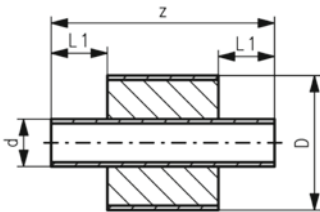

d/D (mm)	PN (bar)	SDR	Code GF	Reece Code	Weight (kg)	L1 (mm)	z (mm)	Closest Inch (inch)
32/90	16	11	738 913 408	1470429	0.126	36	151	1
40/110	16	11	738 913 409	1470430	0.188	40	155	1 ¼
50/110	16	11	738 913 410	1470431	0.226	44	163	1 ½
63/125	16	11	738 913 411	1470432	0.328	48	171	2
75/140	16	11	738 913 412	1470433	0.447	55	185	2 ½
90/160	16	11	738 913 413	1470434	0.631	62	199	3
110/180	16	11	738 913 414	1470435	0.929	72	219	4
160/250	16	17	738 913 417	1470436	1.576	90	255	6
225/315	16	17	738 913 420	1470437	3.254	110	295	8



COOL-FIT 4.0 Barrel nipple

Model:

- PE100, SDR11/17, metric
- For the shortest possible connection between fittings
- For media temperatures between 0°C up to 60°C
- COOL-FIT 4.0 Adhesive ring needed for joining

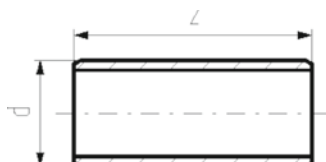

d (mm)	SDR	PN	Code GF	Code Reece	Weight (kg)	z (mm)	Closest Inch (inch)
32	11	16	738 910 408	1470199	0.020	72	1
40	11	16	738 910 409	1470200	0.034	80	1 ¼
50	11	16	738 910 410	1470201	0.059	88	1 ½
63	11	16	738 910 411	1470202	0.101	96	2
75	11	16	738 910 412	1470203	0.162	110	2 ½
90	11	16	738 910 413	1470204	0.264	124	3
110	11	16	738 910 414	1470205	0.454	144	4
140	11	16	738 910 416	1470206	0.855	168	5
160	17	10	738 910 417	-	0.798	180	6
225	17	10	738 910 420	-	1.885	220	8



COOL-FIT 4.0 Adhesive ring

Model:

- Double sided, for sealing connections of fittings with barrel nipple

d (mm)	D (mm)	Code GF	Code Reece	Weight (kg)
32	90	738 010 013	1470064	0.002
40, 50	110	738 010 014	1470065	0.003
63	125	738 010 015	1470066	0.003
75	140	738 010 016	1470067	0.003
90	160	738 010 017	1470068	0.005
110	180	738 010 018	1470069	0.005
160	250	738 010 021	-	0.009
225	315	738 010 023	-	0.027



COOL-FIT 4.0 Sealing clamp-kit

Model:

- Supports the function of the top sealing lip of COOL-FIT 4.0 Fittings for vertical installations outdoor
- Material: stainless steel 304/V2A
- Colour: black

d (mm)	D (mm)	Code GF	Code Reece	Weight (kg)	Pieces/Kit
32	90	738 013 013	1470637	0.250	6
40 - 50	115	738 013 014	1470638	0.300	6
63	125	738 013 015	1470639	0.300	6
75	145	738 013 016	1470640	0.300	6
90	160	738 013 017	1470641	0.300	6
110	180	738 013 018	1470642	0.300	6
160	250	738 013 021	1470643	0.390	6
225	315	738 013 023	1470644	0.450	6

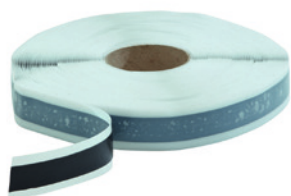

COOL-FIT 4.0 Sealing tape 25mm

Model:

- Supports the function of the top sealing lip of COOL-FIT 4.0 Fittings for vertical installations outdoor
- 30m on a roll, 25mm width, buthylene rubber-based

d (mm)	D (mm)	Code GF	Code Reece	Weight (kg)
32 - 225	90 - 315	738 013 031	1470552	1.400

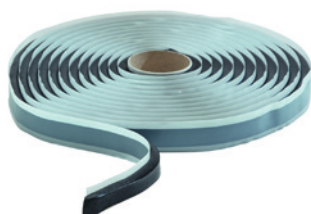

COOL-FIT 4.0 Transition of Insulation

Model:

- For a moisture-proof and vapour tight transition of insulations from COOL-FIT 4.0 to COOL-FIT2.0
- 4.5m on a roll, buthylene rubber-based

d (mm)	D (mm)	Code GF	Code Reece	Weight (kg)
32-110	90-180	738 013 041	1470645	1.400

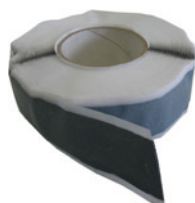

COOL-FIT 4.0 Sealing tape 40mm

Model:

- For a water- and steam-tight sealing of inspection gaps in combination with shrink sleeves/ - sockets
- Sealing tape: 40mm width, buthylene rubber-based
- 30 m on a roll

d (mm)	d-d (mm)	Code GF	Code Reece	Weight (kg)	Closest Inch (inch)
250 - 450	25 - 315	738 011 152	1470636	2.134	¾ -12



Shrink socket PE

Model:

- For a water- and steam-tight sealing in combination with buthylene rubber-based sealing tape
- Length: 100 mm
- "Heavy duty" version for high end applications
- For connections of the same pipe outer diameter

Dn (mm)	d (mm)	Code GF	Code Reece	SP	Weight (kg)	L (mm)
355	250	738 011 024	-	1	0.900	100
400	280	738 011 025	-	1	1.100	100
450	315	738 011 026	-	1	1.900	100
500	355	738 011 027	-	1	1.000	100
560	400	738 011 028	-	1	1.000	100
630	450	738 011 029	-	1	1.000	100

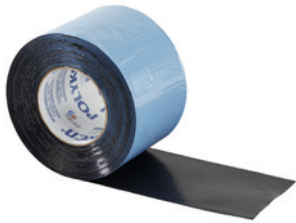

Cold shrink tape PE black

Model:

- For indoor use only
- Width (L) available in 100mm
- 15 m on a roll
- Shrinks without heat application

D (mm)	d-d (mm)	Code GF	Code Reece	Weight (kg)	Closest Inch (inch)
90 - 450	25 - 315	738 011 107	-	1.400	¾ - 8



Hot shrink tape PE black

Model:

- For watertight sealing of outer pipe in underground installations
- Mastic backed
- 30 m on a roll
- Shrink with a burner or hot air gun
- Order sealing patches separately (738 011 109)

D (mm)	d-d (mm)	Code GF	Code Reece	Weight (kg)	L (mm)	Closest Inch (inch)
90 - 630	25 - 450	738 011 108	1470634	3.000	150	¾ - 18

Casing pipe	Length shrink tape
90	360
110	440
125	480
140	530
160	600
180	660
225	800
250	880
280	970
315	1080
355	1210
400	1350
450	1500
500	1660
560	1850
630	2070

Sealing patch

Model:

- For sealing of hot-shrink-tape in underground installations
- Mastic backed
- 1 patch needed per seal

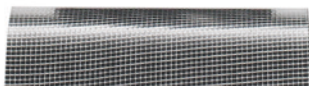

D (mm)	d-d (mm)	Code GF	Code Reece	Weight (kg)	L (mm)	Closest Inch (inch)
90 - 630	25 - 450	738 011 109	1470635	0.100	150	¾ - 18

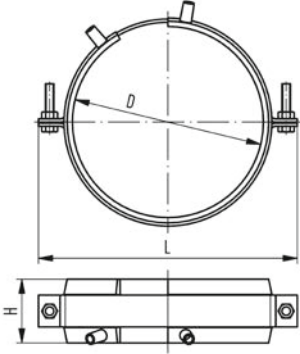

COOL-FIT 4.0 Fixed point

Model:

- The product consists of two components namely electrofusion tapes and pipe brackets.
- Electrofusion welded tape as permanent connection to transmit the forces that occur in the pipe to the fixed point.
- The delivered pipe brackets are needed to deliver welding pressure during installation and give stability during operation.
- For welding, use an MSA2.x, MSA4.x, MSA 250, 300, 350, 400 or commercially available 220 V fusion machines.
- If you use an MSA fusion machine from GF Piping Systems, use the 799 350 339 adapter or the 790 156 032 y-cable set.
- Please take note of the maximum allowed forces for this version in the table below.
- **Fixed point brackets and cross braces have to be calculated and obtained by the installer. They are not included in the fixed point set from GF.**

D (mm)	d (mm)	Code GF	Code Reece	SP	Weight (kg)	L (mm)	H (mm)	max Force (kN)	Closest Inch (inch)
90	32	738 912 013	1470208	1	0.895	170	60	2.0	1 ¼ - 1 ½
110	40 - 50	738 912 014	1470209	1	0.904	180	60	3.0 / 5.0	2
125	63	738 912 015	1470210	1	1.103	215	60	8.0	2 ½
140	75	738 912 016	1470211	1	1.188	220	60	10.0	3
160	90	738 912 017	1470212	1	1.177	255	60	10.0	4
180	110	738 912 018	1470605	1	1.530	255	60	10.0	4
250	160	738 912 021	1470606	1	1.957	335	60	10.0	6
315	225	738 912 023	1470607	1	2.388	400	60	10.0	8
355	250	738 912 024	-	1	2.388	420	60	10.0	10



COOL-FIT Y Cables kit

- The COOL-FIT Y cables are used to speed up the installation of the fixed points electrofusion tapes. The Y cables allow the welding in parallel of 2 E-Tapes, halving the total duration of the fusion process.
- Compatible with all MSA Units

Type	Code GF	Code Reece	Weight (kg)
4 leads cable with 2mm plugs in output	790 156 032	-	0.385

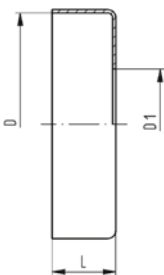

COOL-FIT 4.0 Endcap

Model:

- To protect the insulation at the end of a COOL-FIT 4.0 piping system

d (mm)	D (mm)	D1 (mm)	Code GF	Code Reece	Weight (kg)	L (mm)	Closest Inch (inch)
250	355	265	733 960 185	1470553	0.155	35	10
280	400	300	733 960 186	1470577	0.185	35	10
315	450	335	733 960 187	1470554	0.225	35	12
355	500	370	733 960 188	1470555	0.269	35	14
400	560	420	733 960 189	1470580	0.269	35	16
450	630	470	733 960 190	1470556	0.269	35	18



Sealant

Model:

- For sealing and glueing caps
- 290ml cartridge size

	Code GF	Code Reece	SP	Weight (kg)
290 ml	738 011 103	-	1	0.473



COOL-FIT 2.0/4.0 Adhesive cement

Model:

- For the jointing of NBR foam insulations of flexible hoses and transition fittings

	Code GF	Code Reece	SP	Weight (kg)
	738 010 060	1470071	1	0.240

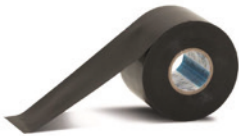

COOL-FIT 2.0/4.0 Adhesive tape

Model:

- For the jointing of NBR foam insulations of flexible hoses and transition fittings
- 30m on a roll

	Code GF	Code Reece	SP	Weight (kg)
	738 010 065	1470072	1	0.400



Tangit KS Cleaner

- Special cleaner for plastic fusion connections in the material of PP, PE, PVDF and PB
- Suitable for Tangit Rapid. Must not be used for solvent cementing
- DVGW approved
- DW 5290 BR 0464

Size	Code GF	Code Reece	Weight (kg)
1 liter	799 298 023	1470617	0.872



Tangit KS - Cleaning Tissues

- Special cleaner for plastic fusion connections in the material of PP, PE, PVDF and PB
- Suitable for Tangit Rapid. Must not be used for solvent cementing
- For plastic welding joints PB, PE, PP, PVDF
- DW 5290 BR 0464
- DVGW approved

Contents	Code GF	Code Reece	Weight (kg)
1 dispenser with 100 tissues	799 298 024	1470557	0.333



Marker

Type	Code GF	Code Reece	Weight (kg)
silver	799 350 364	1470618	0.010

KLIP-IT pipe clip type 061 PP metric

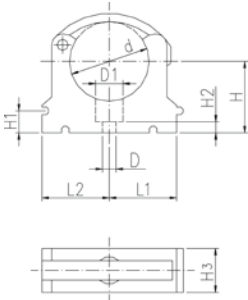

Model:

- Material: clip and safety clip PP black, UV resistant
- d16 - d63: height designed for ball valve type 546 and 543
- **Minimum order quantity: standard packagings SP**

d (mm)	d (mm)	Code GF	Code Reece	SP	Weight (kg)
75	2 1/2	167 061 012	1470022	10	0.057
90	3	167 061 013	1470565	10	0.092
110	4	167 061 014	1470566	10	0.117
125	-	167 061 015	1470567	10	0.180
140	5	167 061 016	1470568	10	0.224
160	-	167 061 017	1470569	10	0.242

d (mm)	D (mm)	D1 (mm)	H (mm)	H1 (mm)	H2 (mm)	H3 (mm)	L1 (mm)	L2 (mm)	SC	Closest Inch (inch)
75	9	17	58	10	10	25	52	52	M8	2 1/2
90	9	17	65	10	10	28	65	65	M8	3
110	9	17	75	10	10	28	79	79	M8	4
125	9	17	90	10	10	32	88	88	M8	-
140	9	17	110	10	10	32	98	98	M8	5
160	9	17	108	10	10	32	109	109	M8	6

KLIP-IT spacer type 061 PP

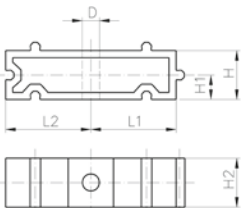

Model:

- For pipe clips type 061/061H, PP black, UV resistant
- **Minimum order quantity: standard packaging SP**

d (mm)	Inch (inch)	Code GF	Code Reece	SP	Weight (kg)	D (mm)	L1 (mm)	L2 (mm)	H (mm)	H1 (mm)	H2 (mm)	SC
75	2 1/2	167 061 162	1470570	10	0.027	9	52	52	20	10	25	M8
90	3	167 061 163	1470571	10	0.039	9	65	65	20	10	28	M8
110	4	167 061 164	1470572	10	0.048	9	79	79	20	10	28	M8
125	4 1/2	167 061 165	1470573	10	0.059	9	88	88	20	10	32	M8
140	5	167 061 166	1470574	10	0.065	9	98	98	20	10	32	M8
160	6	167 061 167	1470575	10	0.071	9	109	109	20	10	32	M8



Pipe clip type 060 PP metric

Model:

- Material: clip and safety clip PP black, UV resistant
- **Minimum order quantity: standard packaging SP or gross packaging GP**
- Accidental opening of the safety clip is not possible
- Clip and safety clip are not assembled in the packaging.
- Pipes with flanges can be installed directly

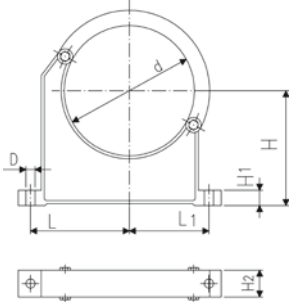

d (mm)	Code GF	Reece Code	SP	Weight (kg)	D (mm)	L (mm)	L1 (mm)	H (mm)	H1 (mm)	H2 (mm)	SC	Closest Inch (inch)
90	167 060 038	1470017	10	0.144	9	89	71	105	15	33	M 8	3
110	167 060 039	1470018	10	0.158	9	94	80	115	15	33	M 8	4
125	167 060 040	1470019	10	0.249	11	116	91	130	20	35	M10	-
140	167 060 041	1470020	10	0.260	11	121	99	130	20	35	M10	5
160	167 060 042	1470021	10	0.296	11	131	107	148	20	35	M10	6
180	167 060 043	1470564	10	0.327	11	143	115	163	20	35	M10	7
200	167 060 019	1470016	5	0.539	13	152	120	175	25	39	M12	8

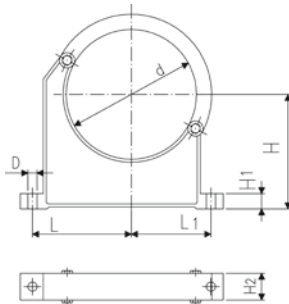

d (mm)	Code GF	Reece Code	SP	Weight (kg)	D (mm)	L (mm)	L1 (mm)	H (mm)	H1 (mm)	H2 (mm)	SC	Closest Inch (inch)
225	167 060 020	-	5	0.178	13	164	132	175	25	39	M12	8
250	167 060 021	1470560	5	0.657	13	183	143	200	25	39	M12	9
280	167 060 022	-	5	0.212	13	197	156	200	25	39	M12	10
315	167 060 023	1470561	5	0.805	13	219	171	225	25	39	M12	12
355	167 060 024	1470562	5	1.251	17	275	209	258	30	50	M16	14
400	167 060 025	1470563	4	1.031	17	300	228	288	30	50	M16	16

Pipe bracket spacing

The pipe bracket spacing have been determined for conveying water on the basis of a specific deflection of the pipe between two clamps considered acceptable.

The pipe bracket spacing for COOL-FIT 4.0 pipe is always consistent independent of pressure and temperature.

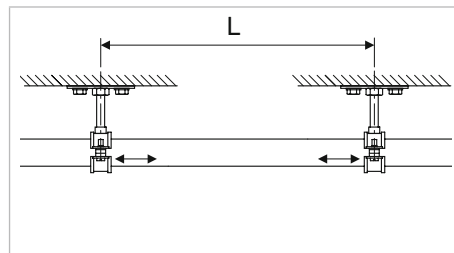

L Pipe bracket spacing

Pipe bracket intervals L for COOL-FIT 4.0

d/D (mm)	32/90	40/110	50/110	63/125	75/140	90/160	110/180	160/250	225/315
L (mm)	1800	1950	1950	2000	2100	2150	2300	2600	2850
d/D (mm)	250/355	280/400	315/450	355/500	400/560	450/630			
L (mm)	3300	3500	3700	3900	4100	4300			

COOL-FIT 4.0 Heat tracing



Self regulating heating cable

Model:

- For pipe freeze protection
- Cut to length on site
- Suitable for in-pipe applications (inside the medium)
- Zero maintenance after installation and commissioning
- No risk of overheating due to self-regulating technology
- Cables featuring self-regulating technology. The heat output automatically adjusts depending on the local temperature at every point along its length. It never overheats even when overlapping

L (m)	Code GF	Code Reece	Weight (kg)
200	790 738 001	-	14.400
62	790 738 003	-	4.460
40	790 738 005	-	2.280
20	790 738 007	-	1.440

Surface sensing programmable thermostat with alarm relay



- The surface sensing thermostat is designed to provide user friendly measurement and control for heating cables. The thermostat has a 25 A control relay (that can be arranged to be volt free) and a 2 A volt free SPDT alarm relay. Parameter and eventual alarm conditions are shown on the digital display and settings can be programmed easily, even without power supply. The thermostat is supplied with a Pt100 sensor. This sensor has a 3 m long silicone extension cable giving freedom to locate the electronics remote from the sensor. Two M25 entries allow for the power cable and heating cable to be connected directly into the unit.

Code GF	Code Reece
790 738 030	-

Cable gland



- For leading the heating inside and outside the COOL-FIT 4.0 piping via threaded fitting

Model:

- Material: brass
- Threaded connection: 3/4 " male thread R

R (inch)	Code GF	Code Reece	Weight (kg)
3/4	790 738 020	-	0.146

Cold lead connection and end seal kit



- For heating cables for COOL-FIT

Model:

- Heat-shrink technique

Inclusive:

- Crimps
- Cold lead shrinkable sleeves
- End seal shrinkable sleeves
- Mastic

Code GF	Code Reece	Weight (kg)
790 738 010	-	0.045

COOL-FIT 4.0 Tools



COOL-FIT 2.0/4.0 Foam removal and peeling tool

Model:

- Tool for foam removal and peeling of COOL-FIT 2.0 and 4.0 pipes

d (mm)	Code GF	Code Reece	Weight (kg)
32-90	799 738 001	1470283	10.500
110-225	799 738 003	1470284	16.500
250-450	799 738 004	-	71.00

MSA 2.1 Automatic Electrofusion Unit with protocols retrieval



The MSA 2.1 automatic electro fusion unit combines light weight and high efficiency, thanks to its inverter technology and furthermore provides fusion documentation in PDF. The unit is extremely fast and simple, with three basic operations required to operator: connect, scan, start the fusion. It is robust, safe and ergonomic.

All is meant to simplify the job: the barcode scanner, for long distance reading, the cooling system to joint in series, the icon system, to keep the interaction between user and machine intuitive. The entire welding process is controlled and regulated with energy output compensation depending on ambient temperature and the indication of cooling time.

The unit has 1000 protocols permanently stored in the internal memory. The user can copy the fusion reports in an USB stick to print them out in PDF format.

Scope of delivery includes: transport box, angle adapters (4.0 mm and 4.7 mm), operating instructions, START/STOP badge and USB memory stick with PC applications.

Technical Data:

- Operating temperature: -20°C to +50°C
- Mains voltage and frequency: 230V (190V - 265V), 50-60Hz
- Fusion voltage: 8-42 V (48 V)
- Fusion data input mode: bar code, manual
- Fusion current: 90 A (max)
- Suggested power generators: 3.5 kVA
- USB Port: Type A
- Protection factor: Class 1 / IP 65
- Mains cable: 4 m / Fusion cable: 4 m
- Weight: ca. 11.9 kg
- Display: Graphical LCD, adjustable contrast
- Independent from languages

Type	Code GF	Code Reece	Weight (kg)
Barcode scanner, transport case, mini Welding Book	790 156 003	1470286	20.000
Barcode scanner, transport case, mini Welding Book, 8m fusion cable	790 156 010	-	21.000

Long adapters

- Adapters for Electrofusion units with 4 mm connectors.
- Longer version, suitable for all COOL-FIT 4.0 dimensions.

Type	Code GF	Code Reece	Weight (kg)	Description
4,0 mm	790 128 035	-	0.058	Angle adapters pair, black

COOL-FIT 4.0 Clamps and installation aids



Double clamp with universal link

- Recommended for the installation of fittings ELGEF Plus and ecoFIT d40 - 200 and d160 - 630mm
- Recommended for the installation of fittings COOL-FIT d32/D75 - d140/D200 and d160/D250 - d450/D630
- The clamping allows installation without tension and avoids movement during fusion and cooling time
- The centrally located adjustable universal link allows installation of electrofusion couplers, elbows and reducers
- Works above, below and alongside the joint
- Adaptor for use with Tee-pieces available (see accessories)

d (mm)	d1 (inch)	Code GF	Code Reece	Weight (kg)	Description	L (mm)	B (mm)	H (mm)
40	200	799 301 490	1470281	4.200	Scope of delivery: 2 x V-block, 2 x Straight bar, 1 x Universal link, Transport bag (600x380x250)	960	290	230
160	630	799 301 496	1470282	14.100	Scope of delivery: 2 x V-block, 2 x Straight bar, 1 x Universal link, Transport bag (780x780x580)	1300	670	550



Quadruple clamp with universal link

- Recommended for the installation of fittings ELGEF Plus and ecoFIT d40 - 200 and d160 - 630mm
- Recommended for the installation of fittings COOL-FIT d32/D75 - d140/D200 and d160/D250 - d450/D630
- The clamping allows installation without tension and avoids movement during fusion and cooling time
- The centrally located adjustable universal link allows installation of electrofusion couplers, elbows and reducers
- Universal use; works above, below and alongside the joint
- Adaptor for use with Tee-pieces available (see accessories)

d (mm)	d1 (mm)	Code GF	Code Reece	Weight (kg)	Description	L (mm)	B (mm)	H (mm)
40	200	799 301 489	1470646	8.300	Scope of delivery: 4 x V-block, 2 x Straight bar, 1 x Universal link, Transport bag (600x380x250)	960	290	230
160	630	799 301 495	1470647	23.300	Scope of delivery: 2 x V-block, 2 x Straight bar, 1 x Universal link, Transport bag (780x780x580)	1300	670	550



Tee adaptor

- Suitable for clamping tool (799301489 - 495)

d (mm)	d1 (mm)	Code GF	Code Reece	Weight (kg)	Description	L (mm)	B (mm)	H (mm)
40	200	799 301 491	-	0.610	Tee adaptor	600	50	40
160	630	799 301 497	-	3.500	Tee adaptor	1070	75	60



V-block

- Suitable for clamping tool (799301489 - 495)

d (mm)	d1 (inch)	Code GF	Code Reece	Weight (kg)	Description	L (mm)	B (mm)	H (mm)
40	200	799 301 492	-	1.000	V-block complete	290	230	65
160	630	799 301 498	-	3.200	V-block complete	660	430	90



Bar extension

- Suitable for clamping tool (799301489 - 495)

d (mm)	d1 (inch)	Code GF	Code Reece	Weight (kg)	Description	L (mm)	B (mm)	H (mm)
160	630	799 301 499	-	1.000	Bar extension	1000	40	40

COOL-FIT 4.0 Spare parts



COOL-FIT 2.0/4.0 Insulation for ball valve type 546 / 542

Model:

- Set consisting of half shells and clamps

Note:

Suitable for COOL-FIT ball valve only

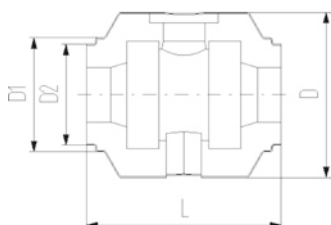

d (mm)	DN (mm)	Code GF	Code Reece	Weight (kg)	D (mm)	L (mm)	D2 (mm)	D1 (mm)
32	25	738 990 308	1470287	0.160	132	152	82	97
40	32	738 990 309	1470288	0.228	157	170	97	117
50	40	738 990 310	1470289	0.282	169	184	97	117
63	50	738 990 311	1470290	0.498	204	227	117	132
75	65	738 990 312	1470291	0.935	235	276	132	147
90	80	738 990 313	1470292	1.033	255	297	147	168



COOL-FIT 2.0/4.0 Insulation for butterfly valve type 567

Model:

- Set consisting of half shells and clamps

Note:

Suitable for COOL-FIT butterfly valve only

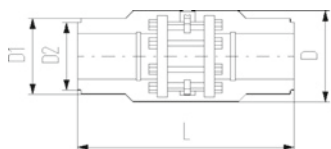

d (mm)	DN (mm)	Code GF	Code Reece	Weight (kg)	D (mm)	D1 (mm)	D2 (mm)	L (mm)
110	100	738 990 324	1470293	2.054	310	188	168	556
160	150	738 990 327	-	3.675	358	259	-	720
225	200	738 990 330	-	4.811	409	325	-	776



COOL-FIT 2.0/4.0 Insulation for flange adaptor

Model:

- Set consisting of half shells and clamps

Note:

Suitable for COOL-FIT flange adaptor only

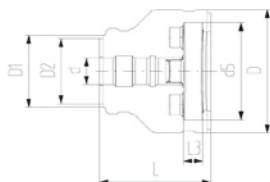

d (mm)	DN (mm)	Code GF	Code Reece	Weight (kg)	D (mm)	D1 (mm)	D2 (mm)	L (mm)	L3 (mm)	d5 (mm)
32	25	738 990 458	-	0.226	135	90	75	162	26	121
40	32	738 990 459	-	0.331	170	110	90	165	28	146
50	40	738 990 460	-	0.386	180	110	90	178	30	156
63	50	738 990 461	-	0.533	200	125	110	230	32	171
75	65	738 990 462	-	0.674	220	140	125	232	34	191
90	80	738 990 463	-	0.754	240	160	140	245	35	206
110	100	738 990 464	-	0.889	270	180	160	254	36	235
160	150	738 990 467	-	2.820	358	259	-	332	34	295
225	200	738 990 470	-	3.710	423	325	-	383	37	354



COOL-FIT 4.0 Insulation for adaptor fittings PE-metal thread

Model:

- Set consisting of half shells and clamps
- Type A: Female thread RP, NPT, loose nut G
- Type B: Male thread R, NPT
- Type C: Both female and male thread

d (mm)	Code GF	Code Reece	Weight (kg)	Type
32	738 990 408	-	0.064	A
32	738 990 418	-	0.045	B
40	738 990 409	-	0.083	C
50	738 990 410	-	0.093	C
63	738 990 411	-	0.111	C



COOL-FIT 4.0 Insulation for adaptor union PE-PE

Model:

- Set consisting of half shells and clamps

d (mm)	Code GF	Code Reece	Weight (kg)
32	738 990 428	-	0.106
40	738 990 429	-	0.166
50	738 990 430	-	0.188
63	738 990 431	-	0.109



COOL-FIT 4.0 Insulation for adaptor union PE-ABS

Model:

- Set consisting of half shells and clamps

d (mm)	Code GF	Code Reece	Weight (kg)
32	738 990 438	-	0.088
40	738 990 439	-	0.107
50	738 990 440	-	0.126
63	738 990 441	-	0.178
75	738 990 442	-	0.374
90	738 990 443	-	0.493
110	738 990 444	-	0.597



COOL-FIT 4.0 Insulation for welding indicator-kit

Model:

- Type A suitable for COOL-FIT 4.0 Fittings d32-d110
- Type B suitable for COOL-FIT 4.0 Fittings d160 and coupler d225
- Type C suitable for COOL-FIT 4.0 Fittings d225 except coupler

d (mm)	Code GF	Code Reece	Weight (kg)	Type	Pieces/Kit
32 - 110	738 010 052	1470631	0.090	A	20
160 - 225	738 010 053	1470632	0.200	B	10
225	738 010 054	1470633	0.033	C	10



Peeling blade d32-d90

- Suitable for COOL-FIT 2.0/4.0 foam removal and peeling tool (799 738 001)

d (mm)	Code GF	Code Reece	Weight (kg)
32	799 738 101	-	0.015
40	799 738 102	-	0.020
50	799 738 103	-	0.019
63	799 738 104	-	0.020
75	799 738 105	-	0.020
90	799 738 106	-	0.030



Peeling blade d110-d225

- Suitable for COOL-FIT 2.0/4.0 foam removal and peeling tool (799 738 003)

d (mm)	Code GF	Code Reece	Weight (kg)
110	799 738 107	-	0.100
140	799 738 108	-	0.100
160	799 738 109	-	0.100
225	799 738 110	-	0.100



Replacement blade foam separator

- Suitable for COOL-FIT 2.0/4.0 foam removal and peeling tool (799 738 004)

Code GF	Code Reece	Weight (kg)
799 738 115	-	0.100



O-Ring for clamping shoe

- Suitable for COOL-FIT 2.0/4.0 foam removal and peeling tool (799 738 001 and 799 738 003)

d (mm)	Code GF	Code Reece	Weight (kg)
32	799 738 050	-	0.003
110	799 738 051	-	0.010



Clamping shoe d32-d90

- Suitable for COOL-FIT 2.0/4.0 foam removal and peeling tool (799 738 001)

d (mm)	Code GF	Code Reece	Weight (kg)	Colour
32	799 738 020	-	0.240	silver
40	799 738 021	-	0.090	red
50	799 738 022	-	0.210	anthracite
63	799 738 023	-	0.120	gold
75	799 738 024	-	0.270	blue
90	799 738 025	-	0.480	black



Clamping shoe d110-d225

- Suitable for COOL-FIT 2.0/4.0 foam removal and peeling tool (799 738 003)
- Type A: Spindle start
- Type B: With pipe stop

d (mm)	Code GF	Code Reece	Weight (kg)	Colour	Type
110	799 738 026	-	0.680	silver	-
140	799 738 027	-	0.480	red	A
140	799 738 037	-	0.480	red	B
160	799 738 028	-	0.580	anthracite	A
160	799 738 038	-	0.580	anthracite	B
225	799 738 029	-	0.600	gold	A
225	799 738 039	-	0.600	gold	B



Clamping shoe d250-d450

- Suitable for COOL-FIT 2.0/4.0 foam removal and peeling tool (799 738 004)
- Type A: Spindle start
- Type B: With pipe stop

d (mm)	Code GF	Code Reece	Weight (kg)	Colour	Type
250	799 738 042	-	0.240	silver	A
250	799 738 052	-	0.240	silver	B
280	799 738 043	-	0.265	red	A
280	799 738 053	-	0.315	red	B
315	799 738 044	-	0.300	anthracite	A
315	799 738 054	-	0.350	anthracite	B
355	799 738 045	-	0.370	gold	A
355	799 738 055	-	0.430	gold	B
400	799 738 046	-	0.450	blue	A
400	799 738 056	-	0.520	blue	B
450	799 738 047	-	0.550	black	A
450	799 738 057	-	0.600	black	B

Circular blade



- Suitable for COOL-FIT 2.0/4.0 foam removal and peeling tool (799 738 001 and 799 738 003)

Code GF	Code Reece	Weight (kg)
799 738 040	-	0.008



Saw blade rotary saw

- Suitable for COOL-FIT 2.0/4.0 foam removal and peeling tool (799 738 004)

Code GF	Code Reece	Weight (kg)
799 738 114	-	0.010



Saw

- Suitable for COOL-FIT 2.0/4.0 foam removal and peeling tool (799 738 003)

d (mm)	Code GF	Code Reece	Weight (kg)
140 - 225	799 738 060	-	1.000



Saw blade

- Suitable for COOL-FIT 2.0/4.0 foam removal and peeling tool (799 738 003)

d (mm)	Code GF	Code Reece	Weight (kg)
140 - 225	799 738 061	-	0.029



Locking pin

- Suitable for COOL-FIT 2.0/4.0 foam removal and peeling tool (799 738 004)

Code GF	Code Reece	Weight (kg)
799 738 116	-	0.250

Located where you need us

Company Details

Legal name: George Fischer Pty. Ltd.

ABN: 37 001 686 399

Website: www.gfps.com/au

Contact Details

Phone no.: 1300 130 149

Email: aus_customerservice@georgfischer.com

Locations Australia

Sydney

Head Office / Warehouse / Workshop

Address: Unit 1, 100 Belmore Road North Riverwood, NSW 2210

Brisbane

Sales Office / Warehouse / Workshop

Address: 18 Kingsbury Street Brendale, QLD 4500

Melbourne

Sales Office

Address: Unit 29, 125 Rooks Road Nunawading, VIC 3131

Perth

Sales Office / Warehouse

Address: 13 Weedon Road Forrestdale, WA 6112

Locations New Zealand

Wellington

Sales Office / Warehouse

Address: PO Box 40399, Upper Hutt 5140, 13 Jupiter Road

Tel: +64 4 527 9813

The information and technical data (altogether "Data") herein are not binding, unless explicitly confirmed in writing. The Data neither constitutes any expressed, implied or warranted characteristics, nor guaranteed properties or a guaranteed durability. All Data is subject to modification. The General Terms and Conditions of Sale of Georg Fischer Piping Systems apply.

AU_GFDO_BR_00013b_EN (05.21)
© Georg Fischer Piping Systems Ltd
8201 Schaffhausen/Switzerland, 2021



Available at

ACTROL™

reece

hvac