



90° Wraparound Grab Rail & Backrest | RH

Model RBA4150-229



Materials & Features

Stainless steel 90° wraparound WC grab rail with backrest meets the requirements of AS1428.1-2009 and can withstand an applied force of 1100N in any direction when installed correctly. Backrest is site adjustable upon installation to ensure accurate location. The snap flange cover conceals the fixings. Designed for installations with exposed cisterns.

Technical Detail

Rail: 32mm [Dia], 304 Satin Stainless Steel
Backrest: White polyurethane, 40mm thick
Fixings: By others

Available Model

RBA4150-229

90° Wraparound Grab Rail with Integrated Backrest, Right Hand

Related Products

RBA4150-230

90° Wraparound Grab Rail with Integrated Backrest, Left Hand

RBA4090-450

90° Ambulant Grab Rail

RBA4110-990

Shower Rail, Handset & Lever Mixer Kit

Installation

Warning: Grab rails are no stronger than the anchors or walls to which they are attached and must be firmly secured in order to support the loads for which they are intended. Refer local codes and Installation Instructions for location of fixing points, method of attachment, etc.

Important: Installation instructions and current rough-in details should be furnished with each fixture. Do not rough in without certified dimensions. Dimensions are subject to manufacturer's tolerance of +/-10mm.

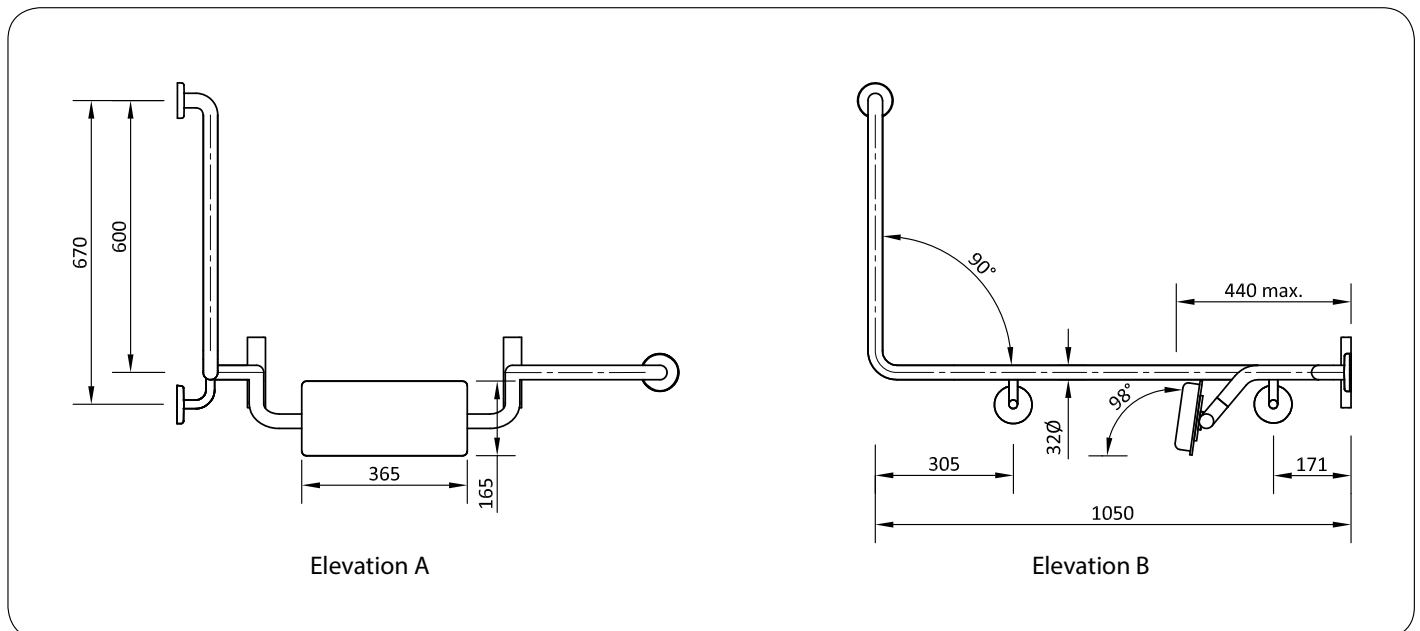

As improvements in the design and performance of RBA products are continuous, specifications may be subject to change without notice. The illustrations and descriptions herein are applicable to production as of the date of this Technical Data Sheet. Revised 06/17 © 2017 by RBA Group TD/Model RBA4150-229/0617