

*Armitage
Shanks*

Piccolo 21 Single lever Monobloc basin mixers

INSTALLATION INSTRUCTIONS

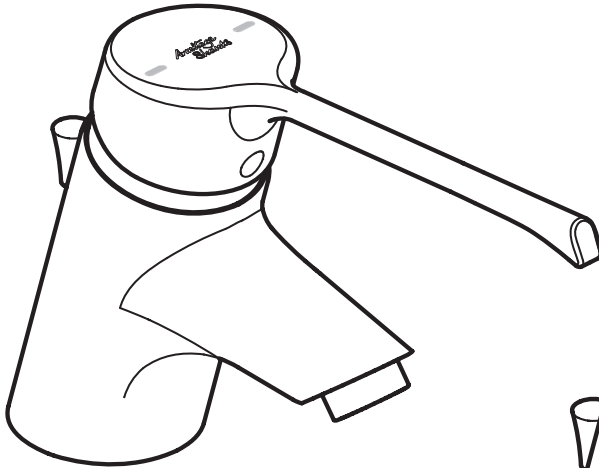

B0997AA Single lever basin monobloc mixer – with long length lever handle, flexible inlet hoses & pop-up waste rod.



WaterMark
AS/NZS 3718 WMK 25822
SAI Global

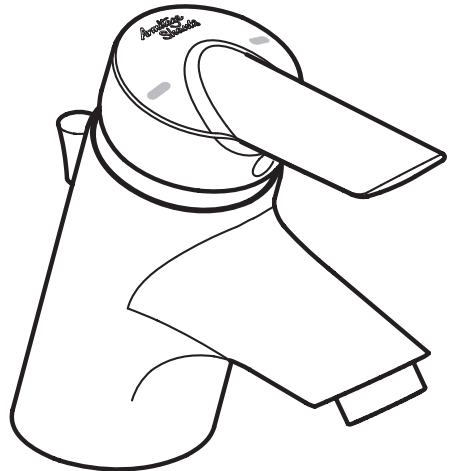

B0999AA Single lever basin monobloc mixer – with standard length lever handle, flexible inlet hoses & pop-up waste rod.

IMPORTANT
BEFORE CONNECTION, FLUSH WATER THROUGH PIPEWORK TO REMOVE ALL DEBRIS ETC. WHICH COULD DAMAGE THE VALVE MECHANISM

INSTALLER: After installation please pass this instruction booklet to user



TABLE OF CONTENT

1	PRODUCT BOX CONTENTS	3
2	DIMENSIONS	4
3	WATER SUPPLY CONDITIONS	5
4	NATIONAL PLUMBING & DRAINAGE CODE	5
4.1	WATER SUPPLY CONTROLLING DEVICES (EXTERNAL)	5
5	INSTALLATION GUIDE	6
6	FLEXIBLE HOSE GUIDELINES	8
7	TAP OPERATION.....	9
8	OUTLET DETAILS	10
9	TEMPERATURE LIMITER	10
10	CARTRIDGE REPLACEMENT	13
11	CLEANING CHROME SURFACES	14
12	SPARE PARTS.....	15
13	SPARE PARTS LIST	16



Piccolo 21 Single lever basin monobloc mixers

B0997AA fitted with long length lever handle

B0999AA fitted with standard length lever handle

These Piccolo 21 products are single lever mixers intended for mounting into a single hole basin. They are ergonomic & simple to operate.

These products feature a single lever ceramic disc cartridge with temperature limiting feature which can be set to prevent accidental scalding.

The cartridge also includes a click feature that encourages water saving. Lifting the handle to the first stop gives 50% flow, beyond the click delivers full flow.

These products are fitted with an anti-vandal outlet which is regulated to 3.8 LPM. The products are also fitted with flexible inlet hoses & include a pop-up rod at the rear to operate a suitable basin waste outlet.

1 PRODUCT BOX CONTENTS



Shown below B0999AA single lever basin mixer – with standard length lever handle.

Coloured index pins to be fitted into the handle as shown. Fit blue pin into the slot on the right.

Depending on local requirements, fit either red or yellow pin into the second slot. Discard the extra pin.

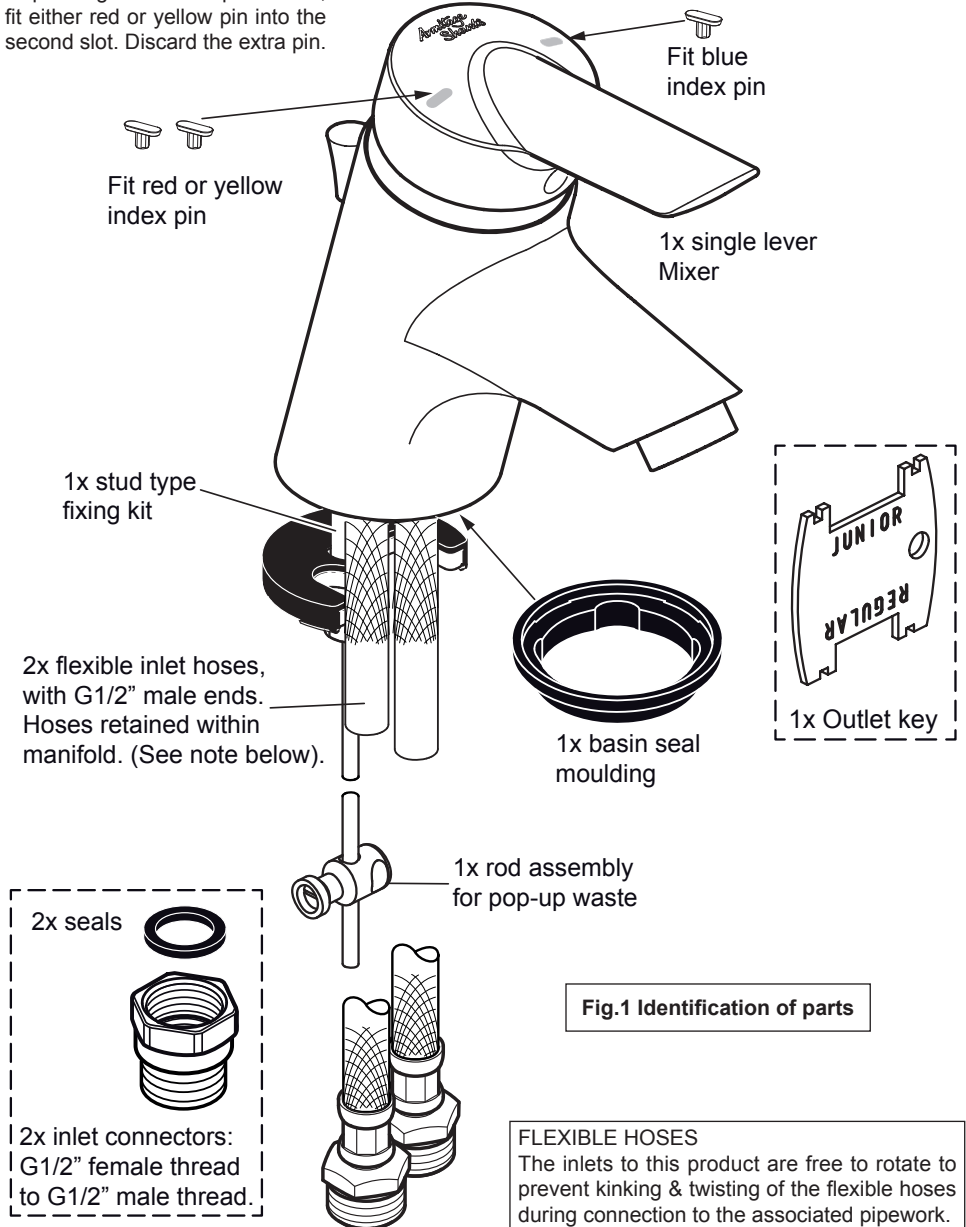

2 DIMENSIONS

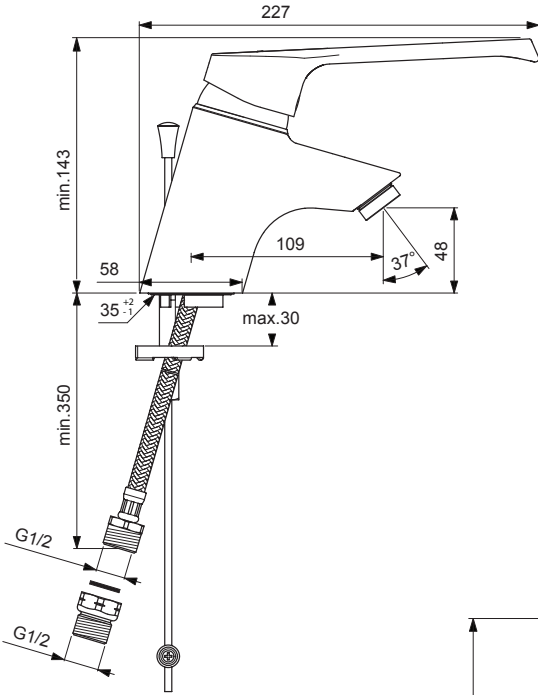

Fig.2a B0997AA Single lever basin monobloc mixer – with long length lever handle, flexible inlet hoses & pop-up waste rod.

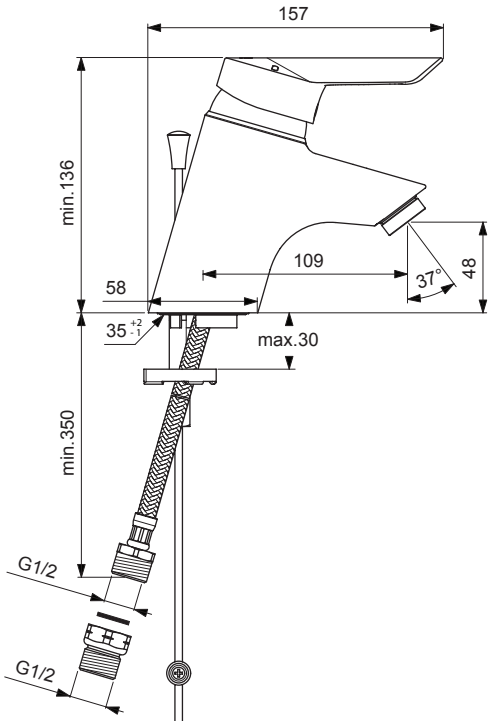
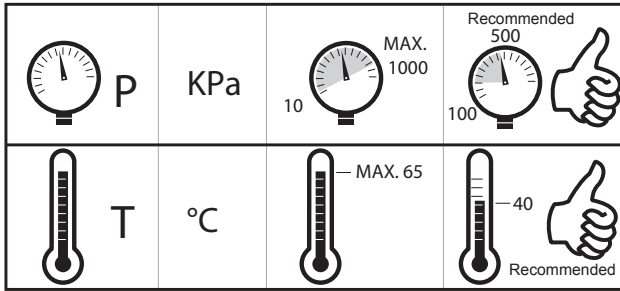

Fig2b B0999AA Single lever basin monobloc mixer – with standard length lever handle, flexible inlet hoses & pop-up waste rod.

Note for installer: fit the most suitable colour of index pin into the handle of the basin mixer. Blue for cold water & either red or yellow for warm water. See sect.1

3 WATER SUPPLY CONDITIONS



Supply temperatures:

Avoid supplying scalding water to the HOT inlet. Hot water temperature supply should be controlled to circa 40°C.

In order to maintain water quality, the hot supply should be stored & distributed at a temperature greater than 55°C.

Use of an appropriate temperature reduction device (i.e. tee pattern thermostat) is recommended to ensure delivery of safe hot water temperatures from the mixer.

Supply pressures:

This product should be plumbed to balanced pressure water supplies for best mixing performance.

The recommended working pressure for self-closing taps is 100 to 500 KPa.

Exceeding this pressure will adversely affect the operation of the taps.

This adverse effect can be overcome by using PRV to reduce the pressure accordingly.

4 NATIONAL PLUMBING & DRAINAGE CODE

The products covered by this installation and maintenance instruction must be installed in accordance with the provisions of AS/NZS 3500 & any relevant local regulations. Installations not complying with AS/NZS 3500 may void the product performance & warranty. Armitage Shanks strongly recommends that this product is fitted by a professional installer.

4.1 Water supply controlling devices (external)

Pressure & temperature ranges of the incoming water supplies should comply with the limits specified above.

NOTE: Maximum recommended static pressure in AS 3500.1.2 is 500 Kpa.

To avoid exceeding this pressure, install a suitable pressure reducing valve - PRV (or pressure limiting valve - PLV) on both hot & cold incoming water supply systems. A suitable location for a PRV on the hot supply may be on the cold inlet to the heating appliance.

Similarly, if the water supply temperature ranges do not conform as above, then suitable temperature controlling devices should be installed to achieve this.

5 INSTALLATION GUIDE



Red, blue & yellow index pins are supplied. The appropriate coloured pins should be pressed into the handle. See sec.1



1

1. Before connection, flush water through pipe-work to remove all debris etc. to prevent damage to the valve mechanism.

2. ENSURE WATER SUPPLIES HAVE BEEN ISOLATED.

3. Remove the fixing kit parts if already assembled to the fixing stud. Flexible hoses are pre-fixed into the mixer body; therefore do not try to remove these. Ensure the basin seal is in place & orientated as shown. The larger diameter of the seal should locate into the base recess of the mixer.

Offer the mixer towards the basin hole. These products will require flexible hoses to be manipulated into the basin hole one at a time.

NOTE: Fixing stud (not shown here) is at the rear of the product, see sect.2.

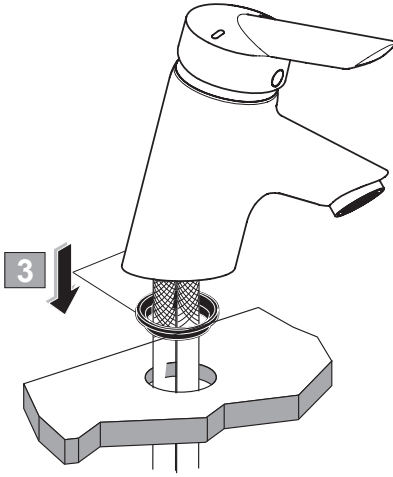

Fig.5a

4. Attach the rubber gasket to the clamping plate. With the gasket uppermost slide this assembly onto the fixing stud using the hole in the gasket & plate.

Hand tighten the nut against the clamping plate until the rubber gasket makes contact with the underside of the basin. Ensure the mixer spout is positioned correctly, & then tighten the nut securely with a 13mm A/F socket (or spanner).

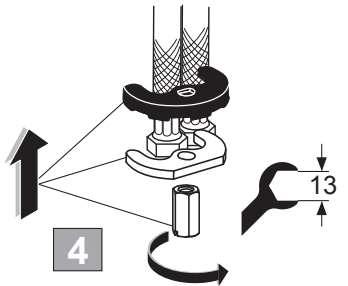

Fig.5b View from rear

Remember to fit isolating valves*.

*Isolation valves should be fitted to permit future maintenance of this product.



DO NOT apply heat near this product. Heat generated by soldering could damage plastic parts and seals.

5 Installation guide continued...

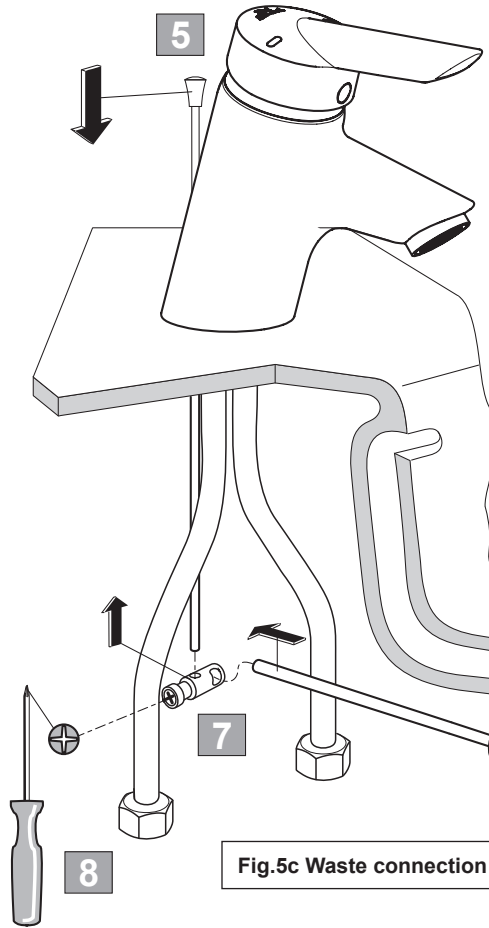

Fig.5c Waste connection

5. Slide the pop-up rod into the hole at the rear of the mixer (through hollow fixing stud).

6. At this stage a pop-up waste suitable for the basin being used should be fitted. A pop-up waste is not supplied with this product. Ensure waste is properly sealed to the basin.

7. Slide the rod clamp onto the vertical pop-up rod, & then manipulate the horizontal rod into the clamp.

8. Using a posi-drive screw driver, tighten the rod clamp slightly & then check the operation of the waste. Make adjustments to the clamp position until the waste opens & closes easily. Finally tighten the screw.

9. Fit inlet connectors onto the ends of both flexible hoses. With the flat washer seals in place, hand tighten the inlet connectors onto the end of the hoses.

To hold the inlet hoses steady, use a 21mm A/F spanner (or adjustable).

With the hose held stationary, tighten the inlet connectors into the hose using 25mm A/F spanner (or adjustable).

10. Connect supply pipes (DN15, Ø12.7mm) to the inlet connectors. Alternatively, flexible hoses (not supplied) can be used which have G1/2" female end connections.

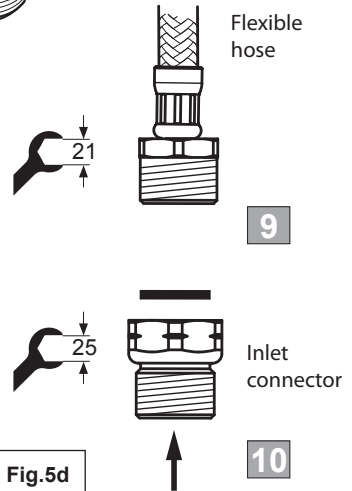

Fig.5d

Fit supply pipe to G1/2" male side

5 Installation guide continued...

SEE SECTION.6 FOR GUIDELINES ON INSTALLING FLEXIBLE HOSES

Ensure LEFT inlet flexible hose is connected to the HOT water supply & conversely the RIGHT inlet to the COLD.



Excessive force is not necessary to achieve a good seal between these parts.

RESTORE SUPPLIES & CHECK ALL JOINTS FOR LEAKS

In-line service valves

IMPORTANT: In-line service valve(s) should be fitted upstream of these products into the supply pipes. Consider a suitable location for the service valves. Orientate the service valve(s) such that the isolating screw(s) are easily accessible for future maintenance.

Ideally use a pair of service valves with integral check valves and filters. An example is shown here:

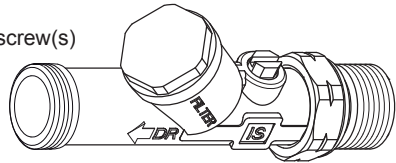

6 FLEXIBLE HOSE GUIDELINES

Fig.5e

Flexible hoses are pre-fitted into these mixers.

Avoid sharp bends, twisting, kinking & stretching these hoses as this may result in damage & reduced water flow.

Hold the hose steady using the end hexagon whilst tightening the inlet connector into the hose.

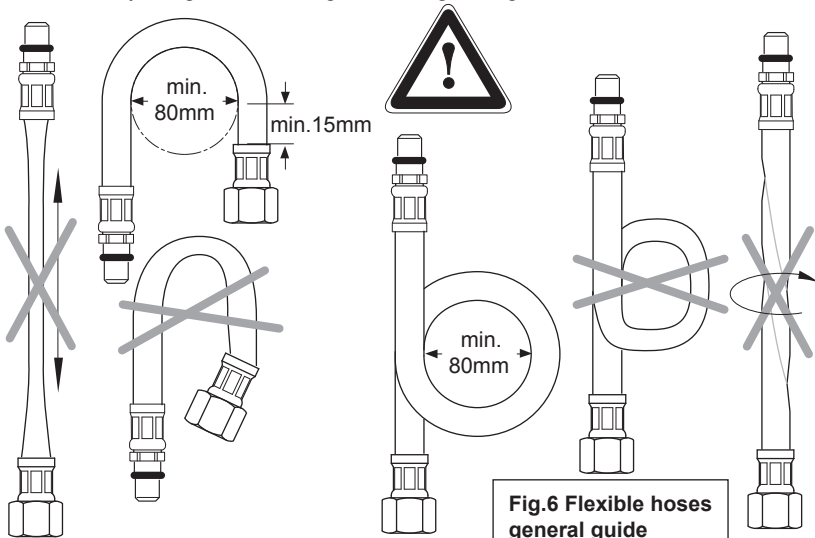

The inlets to this product are free to rotate to help prevent kinking & twisting of the flexible hoses during connection to the associated pipework.

7 TAP OPERATION



To operate this product, simply lift the handle upwards. When the lever is above the spout, water will flow at approximately mid-mix temperature.

To adjust the water temperature, rotate the handle as shown. From the mid-mix position, the handle can rotate about 60° in either direction. See fig.7a.

Clockwise rotation will increase the water temperature.

Lifting the pop-up rod upwards will pull the plug into the waste. Thus allowing the basin to be filled.

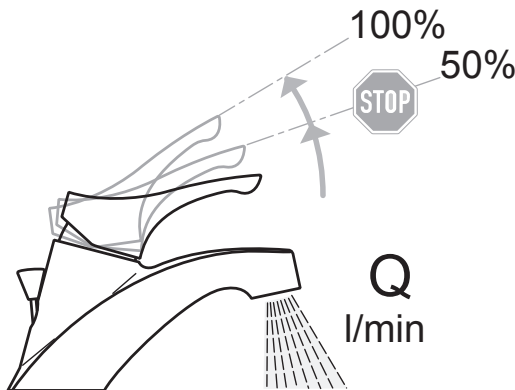
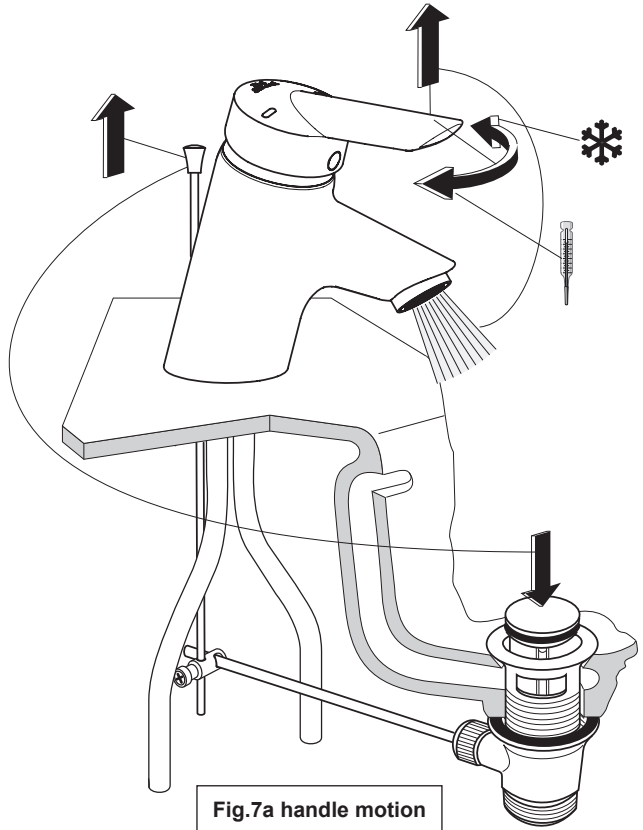

The cartridge includes a click feature that encourages water saving. Lifting the handle to the first stop delivers 50% flow, beyond the click delivers full flow. See Fig.7b.

8 OUTLET DETAILS



This product is factory fitted with a laminar PCA regulated outlet which is secured with an anti-vandal (AV) housing.

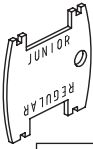

Fig.8a

Table 3 shows the flow rate performance for the flow regulator outlet

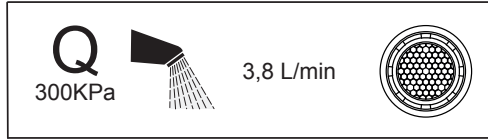

Table 3 Flow rate data (Q=flow rate)

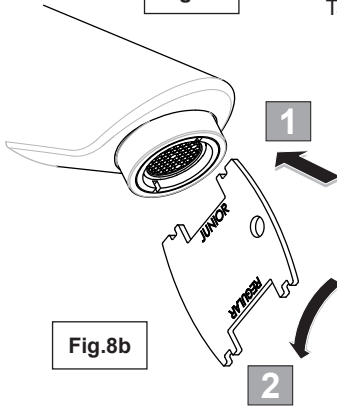

Fig.8b

To replace/clean/service the outlet, use the outlet key supplied with the product to unscrew the AV housing.

1. Using the side of the key marked "junior" locate the key into the inner ring of the housing.

2. Unscrew housing. Change the outlet & re-secure the housing with the key, ensuring the seal is in place. Ensure the outlet housing is adequately tightened to prevent leaks & run back.

9 TEMPERATURE LIMITER

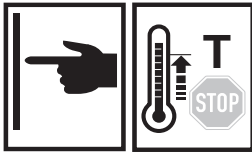

To make adjustments to the temperature limiter it will be necessary to remove the handle & shroud first.

The temperature limiter restricts the handle movement to reduce the volume of hot water available to the cartridge for mixing.

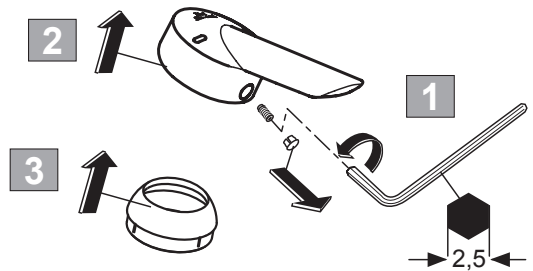

Fig.9a



9 Temperature limiter continued...

ISOLATE WATER SUPPLIES.

Handle removal (see fig.9a)

1. To remove the handle prise out the chrome button, located under the lever of the handle. Insert the 2.5mm hexagonal key into the hole & undo the grub screw a few turns (no need to remove screw completely).
2. The handle should pull away from the mixer body.
3. Pull off the shroud to expose the cartridge.

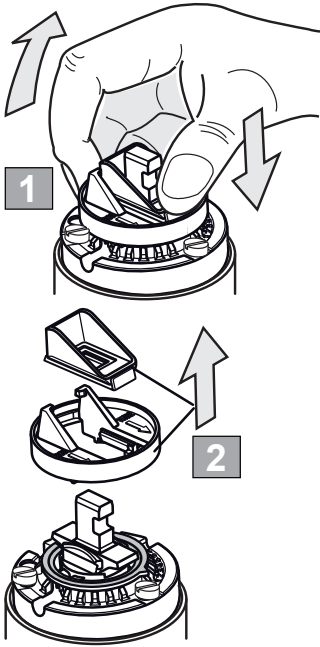

Fig.9b

3. The red adjustment ring is now exposed. Lift the ring about 3mm (trapped) & rotate it to a suitable alternative position & press it back into the cartridge. The cartridge face is marked 0-7, & the adjustment ring is pointing to one of these numbers.

Keep the cartridge spindle parallel to the cartridge.

To gain access to the temperature adjustment ring (see fig 9b):

1. Pull off the green triangular moulding parallel to the cartridge spindle.
2. Push the green cylindrical moulding downwards, in the direction of the arrows marked on this part. This item will “snap out” & can then be lifted away.

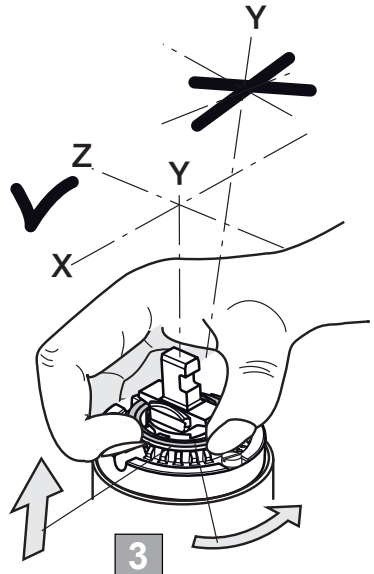

Fig.9c

9 Temperature limiter continued...

Position "0" provides the warmest water & allows the handle to travel furthest towards the hot. Position 9 provides the least warm water (positions 8 & 9 fall into the cutaway, so not marked).

Fig 9d shows mid mix-temperature position & red adjustment ring pointer at "0".

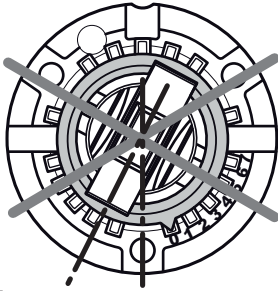

Fig.9d

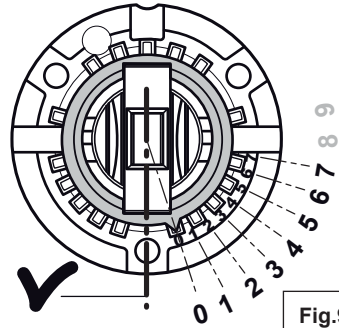

Fig.9e

4. Both green mouldings can be refitted to the cartridge. The cylindrical moulding will snap back into position. Shroud & handle can be refitted. Restore water supplies. Check showering water temperature. If not correct, adjust the red ring again.

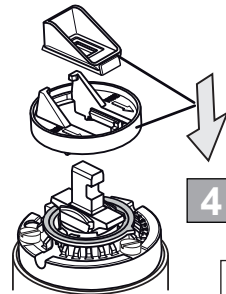

Fig.9f

As a rough guideline, the table below shows the approximate showering water temperatures expected from the supply temperatures specified.

Showering temperature is dependent on inlet water supply temperatures & pressures.



 P 300 KPa			0	1	2	3	4	5	6	7	8	9
			°C	°C	°C	°C	°C	°C	°C	°C	°C	°C
50°C	16°C		49,5	49,5	48	46	42,5	41	37	33,5	31	28
65°C	16°C		65	65	63,5	60,5	57	53,5	49	44,5	39	34,5
81°C	16°C		81	81	78,5	73	69	63,5	56	49	42,5	36

Fig.9g



Installer: Ensure product is delivering safe hot water for the end user. Our recommended maximum temperature for hand washing is 40°C.

10 CARTRIDGE REPLACEMENT

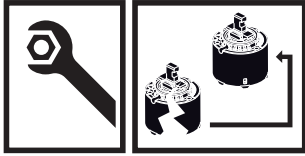

Before deciding on a replacement cartridge make sure the cartridge inlet & outlet ports not blocked with debris.

Handle removal: Firstly remove the handle as detailed in section 9. ENSURE WATER SUPPLIES HAVE BEEN ISOLATED.

1. With the handle removed, gently pull off the chromed shroud surrounding the cartridge
2. Using a flat blade screw driver, undo the 3 long screws retaining the cartridge to the mixer body. Access to screw heads will be improved by removing the two green "click" mouldings from the top of the old cartridge as detailed in section 9.

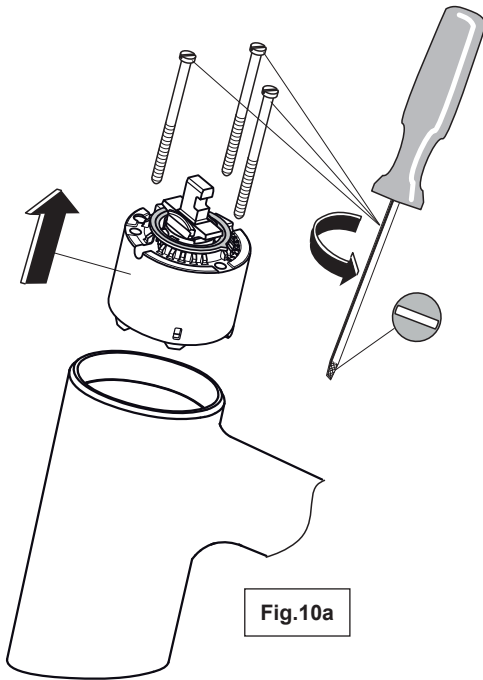

NOTE: these screws also retain the manifold moulding below the cartridge. Manifold will become loose (retained only by peripheral O-rings), so maintain its orientation in the mixer body (no need to remove the manifold).

3. Lift the cartridge upwards & withdraw it from the mixer body
4. Reposition the red temperature limiting ring on the new cartridge to the same position as the old cartridge. See figs 9c & 9e.

Refit the two green mouldings onto the new cartridge.

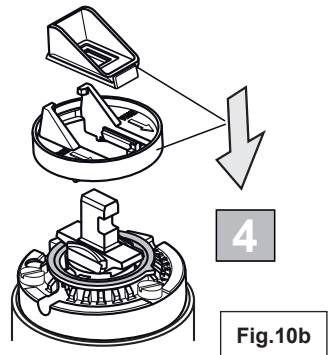

TAKE CARE NOT TO DAMAGE CHROMED SURFACES

10 Cartridge replacement continued...

5. Observe the cartridge as shown here with the large circular outlet port to the top. The two small tear-drop shaped ports are the inlets.

Slide the fixing screws into the new cartridge body.

Align the cartridge ports to the manifold moulding ports & slide the screws also into the manifold.

Align the screws to the threaded holes in the mixer body & fasten screws. Ensure all seals are correctly in place.

Shroud & handle can be refitted. Restore water supplies. Check for leaks.

Check hand washing water temperature. If not correct, adjust the position of the red temperature limiting ring. See section 9.

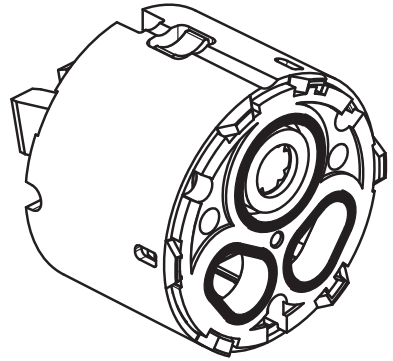
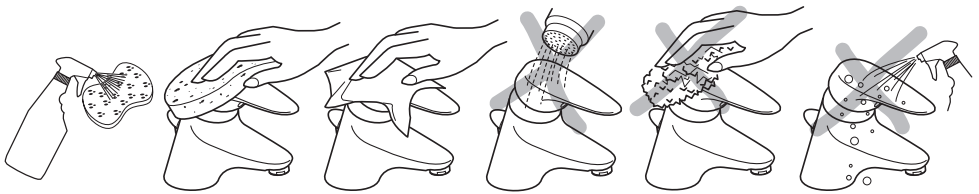

Fig.10c

11 CLEANING CHROME SURFACES



When cleaning chromed products use only a mild detergent, rinse & wipe dry with a soft cloth. Ideally clean after each use to maintain appearance.

Never use abrasive, scouring powders or scrapers. Never use cleaning agents containing alcohol, ammonia, hydrochloric acid, sulphuric acid, nitric acid, phosphoric acid or organic solvents. Use of incorrect cleaning products / methods may result in chrome damage which is not covered by the manufacturer's guarantee.

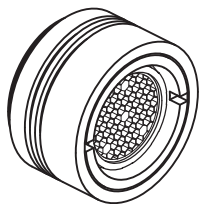

Outlet cleaning

On a regular basis the outlet should be inspected & cleaned. To unscrew and remove the outlet, see section 8.

In areas where lime scale build-up is prevalent this should be avoided by regular cleaning. If it should build up, it will have to be removed. An inhibited proprietary scale solvent can be used such as a kettle de-scaling solvent but it is important to follow the manufacturer's guidelines. After de-scaling it is important to rinse the parts thoroughly in clean water.

Clean carefully and do not use abrasive materials or scrapers.

12 SPARE PARTS

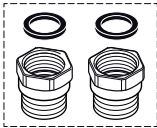
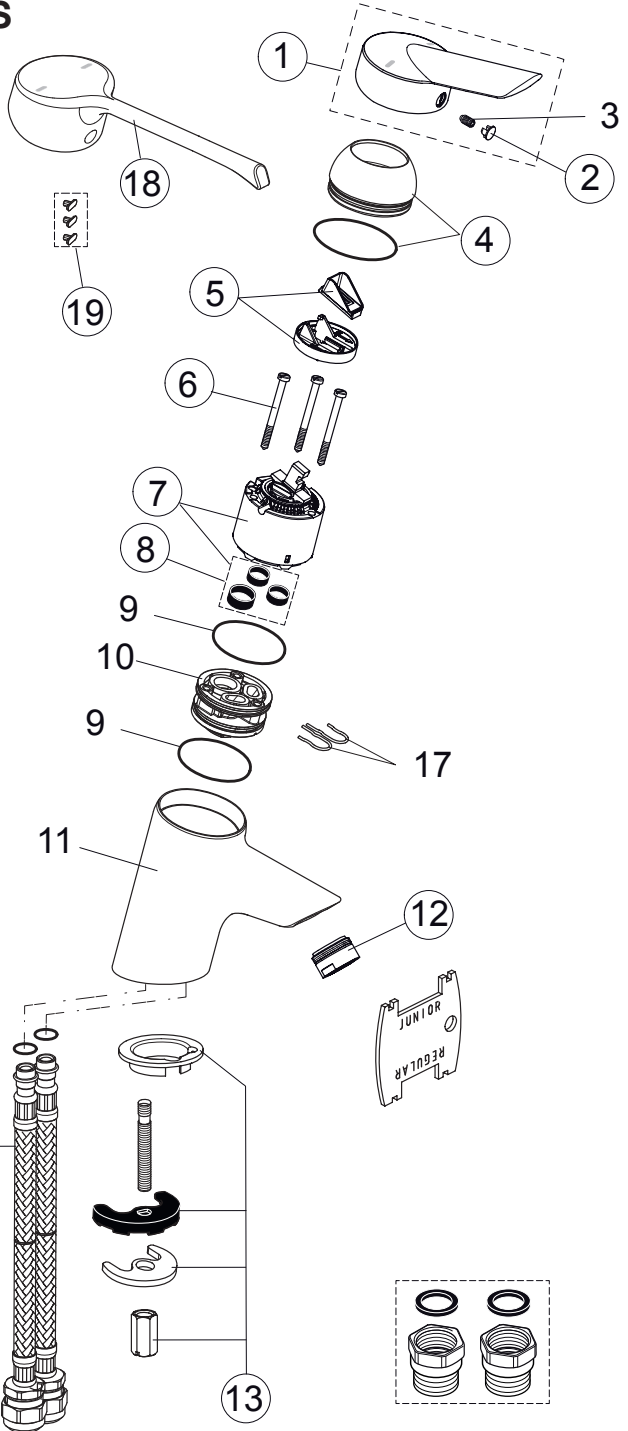
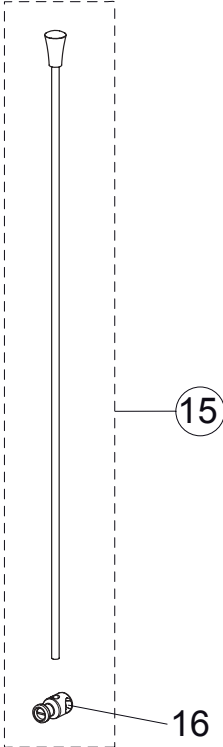
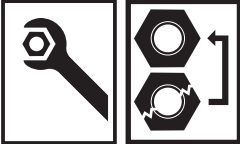

13 SPARE PARTS LIST

Ref.	Description	Part No.
1	Lever complete for B0999AA w.logo AR	A861047AA
2	Handle cap	B960473AA
3	Thread pin M5 x 10	A963309NU
4	Cover cap	B960276AA
5	ECO-kit	A860 700NU
6	Cylindrical screw M4 x 69	A963783NU
7	Cartridge Ø47 complete	A960500NU
8	Sealring Set	A961155NU
12	Areator with key	A860970AA
13	Fixation kit	B960187NU
15	Pop-up rod	B964883AA
18	Lever complete for B0997AA w.logo AR	A861048AA
19	Set of pins	A861040NU



CUSTOMER CARE HELPLINE:

+44 (0)844 543 6170

CUSTOMER CARE FAX:

+44 (0)844 543 6171

CUSTOMER CARE EMAIL:

aftersalesnonresidential@armitageshanks.co.uk

Armitage Shanks pursues a policy of continuing improvement in design and performance of its products.

This right is therefore reserved to vary specification without notice.

Armitage Shanks limited
 Armitage
 Near Rugeley
 Staffordshire
 WS15 4BT
 England
 +44 (0)870 122 8822

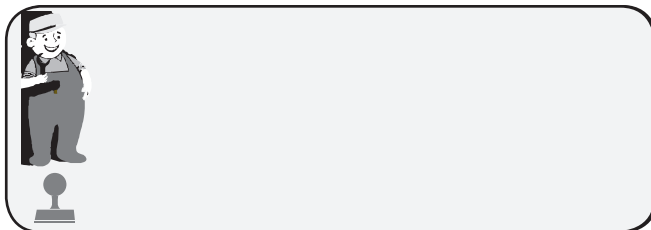

*Armitage
Shanks*

1115 / A 868 111
 Made in Germany



REECE PRODUCT QUALITY GUARANTEE

You have purchased a product from Reece Australia Pty Ltd ABN 84 004 097 090 ("Reece"). This product is covered by a 5 year replacement product warranty and a 12 month warranty over spare parts and labour.

5 YEAR PRODUCT WARRANTY

This warranty covers faults in the construction, material and assembly of finished products. Products which are within 5 years from the date of purchase, found upon inspection by an authorised Reece representative to be defective in construction, material or assembly, will be repaired or exchanged with an equivalent product free of charge. Replaced items become Reece's property.

This warranty also covers any spare parts included under "Manufacturer's Provisions" below.

Manufacturer's Provisions

The following spare parts are covered by a 10 year warranty:

- Mixer Cartridge

ONE YEAR SPARE PARTS WARRANTY

Spare parts other than those listed in the Manufacturer's Provisions above which are within 1 year from the date of purchase found upon inspection by an authorised Reece representative to be defective in construction, material or assembly will be replaced free of charge. Replaced items become Reece's property.

AVAILABILITY OF REPLACEMENT PRODUCTS AND SPARE PARTS

All replacement products and spare parts will be available for collection without charge to the customer at the nearest Reece branch to the customer's location, or elsewhere as agreed between the customer and Reece.

LABOUR

The labour for the replacement of products that are within one year from the date of purchase found upon inspection by an authorised Reece representative to be defective in construction, material or assembly, and in relation to all spare parts to which this warranty applies, will be supplied by Reece or the relevant supplier using licensed plumbers engaged by Reece or the relevant supplier

WARRANTY CONDITIONS

This warranty will apply only under all of the following conditions:

- The item has been installed by a licensed plumber
- Failure is due to a fault in the manufacture of the product
- Proof of purchase (including the date of purchase) is provided
- The installation of the product is in accordance with the instructions provided
- The product has been installed in valid applications as stated in accordance with the recommended use

This warranty does not cover products purchased as an ex-display without being fully checked and tested for sale by the manufacturer.

This warranty does not include faults caused by:

- Unsuitable or improper use
- Incorrect installation or installation not in accordance with the instructions provided
- Installation or part installation by any person other than a LICENSED PLUMBER who is suitably qualified to install the product, or a Licensed Electrician where applicable.
- Normal wear and tear
- Inadequate or complete lack of maintenance
- Chemical, electrochemical or electrical influences
- Harsh detergents or abrasive cleaners used on product finishes

EXCLUSIONS

To the fullest extent permitted by law, Reece excludes all liability for damage or injury to any person, damage to any property, and any indirect consequential or other loss or damage.

CLAIM PROCEDURE

For all warranty queries customers are to contact the branch where the product was purchased. These details can be found on your purchase invoice.

General contact details for Reece are as follows:

Reece Australia Pty Ltd
118 Burwood Hwy
Burwood VIC 3125
+61 3 9274 0000
admin@reece.com.au

The benefits given by this warranty are in addition to the other rights and remedies that consumers may have under the Australian Consumer Law and any other applicable laws.

Our goods come with guarantees that cannot be excluded under the Australian Consumer Law. You are entitled to a replacement or refund for a major failure and for compensation for any other reasonably foreseeable loss or damage. You are also entitled to have the goods repaired or replaced if the goods fail to be of acceptable quality and the failure does not amount to a major failure.