

AXA

WILD RIMLESS WALL HUNG PAN

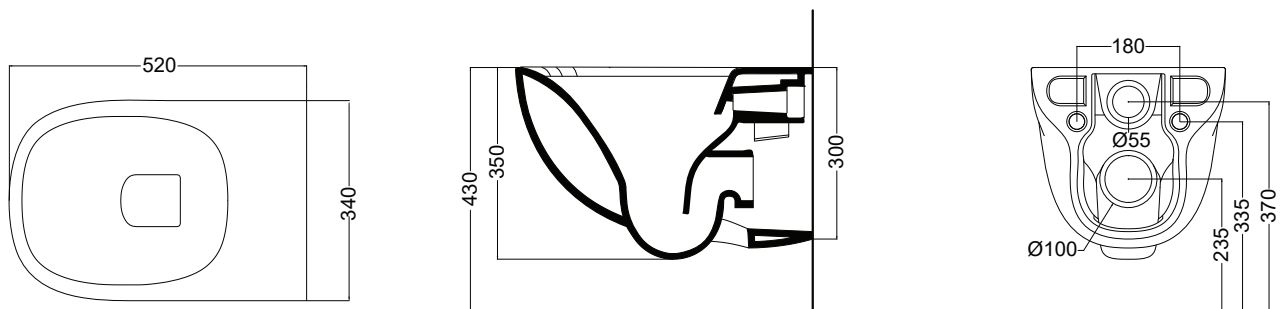

SPECIFICATIONS

Recommended use	Domestic, hotel and commercial
Colour availability	White
Rim configuration	No Rim
Set out	P Trap Only
Pan fixing	Bolted to wall
Seat	Matching top fix seat supplied with suite (soft close)
Material	Vitreous china
Weight	Pan: 22kg
Flushing	4.5/3 litre dual flush
Warranty	15 years (refer to warranty)



To see the complete AXA range go to
www.reece.com.au/bathrooms

CLEANING RECOMMENDATIONS

We recommend the use of soapy water or approved bathroom cleaners.

This bathroom product should not be cleaned with abrasive materials.

Damage caused by any improper treatment is not covered by the product warranty - refer to Warranty Conditions.

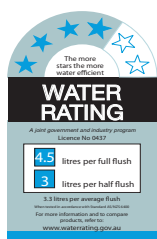

Disclaimer: Products in this specification manual must by regulation be installed by licensed and registered trade people. The manufacturer/distributor reserves the right to vary specifications or delete models from their range without prior notification. Dimensions are nominal measurements only. Dimensions and set-outs listed are correct at time of publication however the manufacturer/distributor takes no responsibility for printing errors.

Tech Page Version 1



AXA

WILD RIMLESS WALL HUNG PAN

INSTALLATION INSTRUCTIONS

Note

In all circumstances the wall onto which the pan is mounted shall be capable of supporting the pan and load without deflection.

All measurements for roughing in should be taken from finished wall/floor. Cistern/wall mounting brackets are not supplied, but fixing kit is. Dimensions shown are nominal measurements only.

1. Rough in positions of water inlet and waste outlet.
2. Screw the fixing bolts onto the protruding all thread ensuring that the cut out is pointing outward (fig 1). Protruding all thread will need to be cut to size.

3. Insert fixing plugs into the wall fixing holes (fig 2). Carefully install pan onto brackets and fix into position with allen key provided
4. Ensure pan is level before tightening.
5. Flush pan to check connections for leaks.
6. Apply flexible sealant and rear of pan to seal to wall.

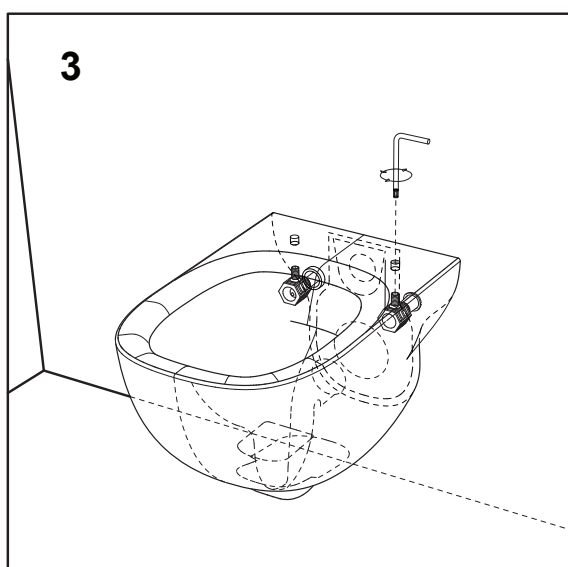
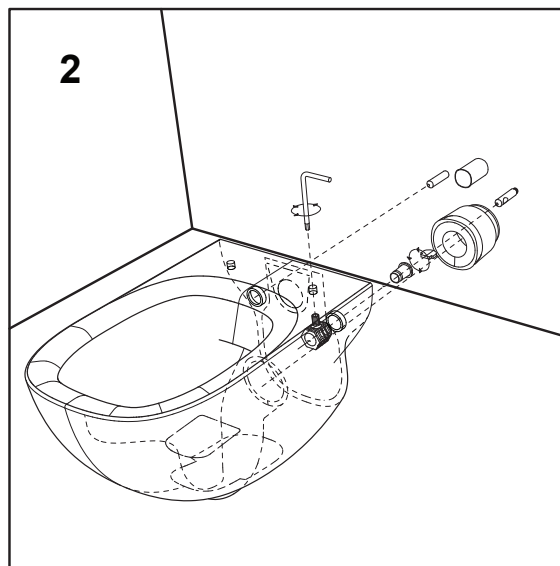
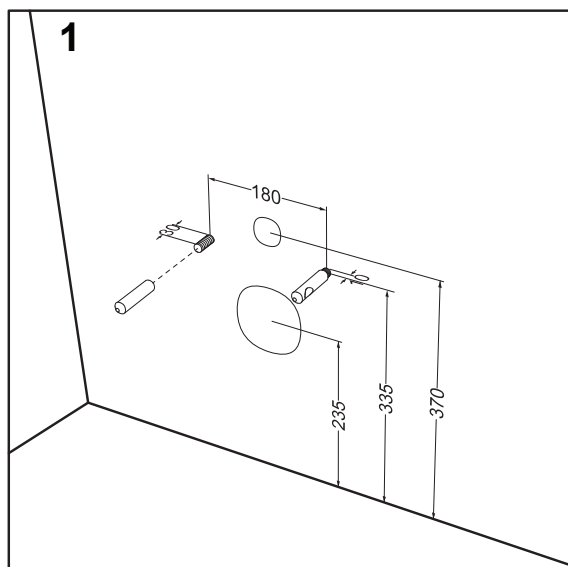

Plumbers, please ensure a copy of the installation instructions is left with the end user for future reference