

Dura

Gear Operator

Materials

Housing	Cast Iron
Cover	Cast Iron
Worm	Carbon Steel
Worm Gear	Ductile Iron
Shaft	Carbon Steel
Handwheel	Cast Iron

Product Image



Dura Gear Operator

Dimensions

Product Code	Product Description	L	H	D	E	C	Ratio	Max Torque Output	Weight Including Gear
		mm	mm	mm	mm	mm		Nm	kg
1011602	DURA GEAR OPERATOR SUIT 50mm - 80mm	165	69	185	108	126	24:1	270	4.9
1011605	DURA GEAR OPERATOR SUIT 100mm - 125mm	165	69	185	108	126	24:1	270	4.9
1011608	DURA GEAR OPERATOR SUIT 150mm	165	69	185	108	126	24:1	270	4.9
1011611	DURA GEAR OPERATOR SUIT 200mm	238	85	290	153	177	30:1	700	9.8
1011614	DURA GEAR OPERATOR SUIT 250mm	238	85	290	153	177	30:1	700	9.8
1011618	DURA GEAR OPERATOR SUIT 300mm	231	92	295	161	198	50:1	1200	12.9

Product Drawing

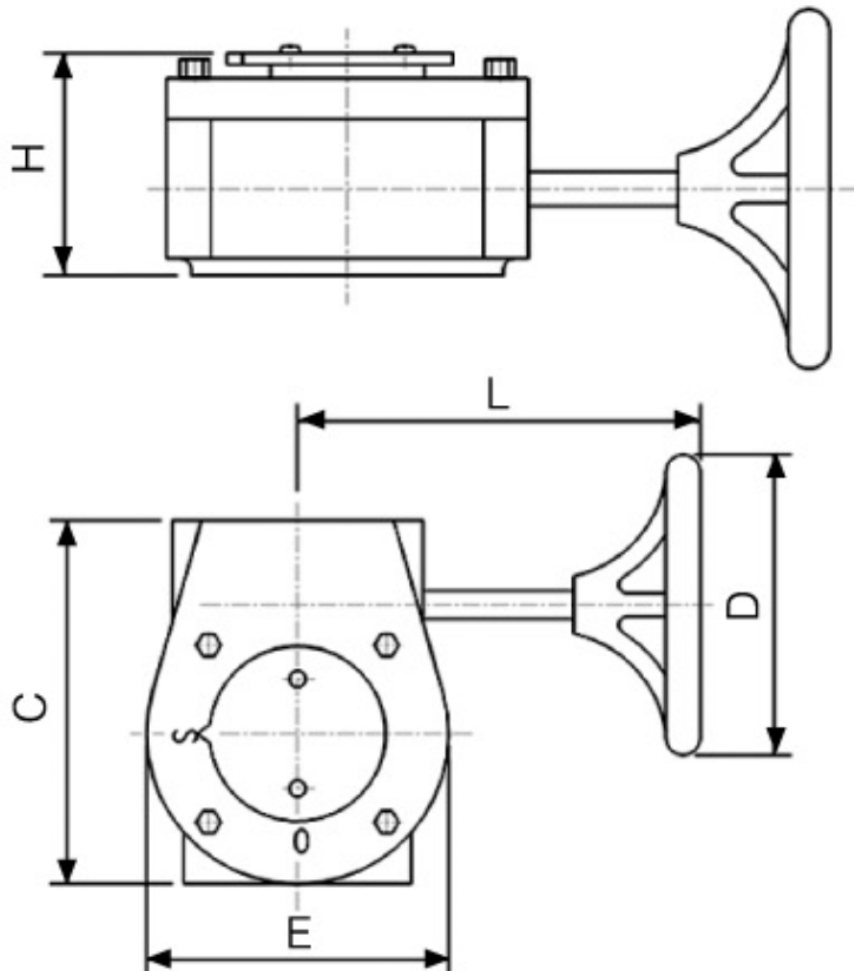



Gear Operator Installation Instruction

Installation of the gear operator and butterfly valve:

- Manually turn the gear operator hand wheel until the indicator is pointed to the open position. **(See Figure 1)**
- Using the handle, manually open the butterfly valve to ensure the disc is in fully open position.
- Remove original handle, notch plate and bolts from the butterfly valve. **(See Figure 2)**
- Fit the gear operator onto the butterfly valve stem, aligning square cutout with square stem, and using 2 bolts from notch plate to bolt them together.

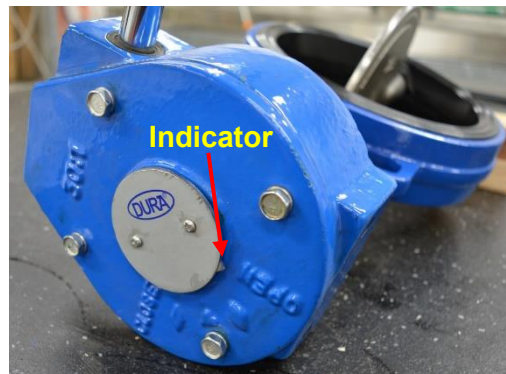

Figure 1

Adjustment of the “Closed” position travel stop:

- Remove the outer set screws to access the adjustment screws **(See Figure 3)**
- Looking at the end of the gear operator **(See Figure 4)**, the top screw is for close adjustment.
- Loosen the close adjustment screw and turn hand-wheel until the valve disc is in fully closed position. (Special note: Fully closed position for the valve disc is against valve rubber seal face. Do not force disc hard into seal face or seal face could be damaged. **(See figure 5)**)
- Carefully re-tighten the close adjustment screw.
- Replace the outer set screw.



Figure 2

Adjustment of the “Open” position travel stop:

- Remove the outer set screws to access the adjustment screws
- Looking at the end of the gear operator **(See Figure 4)**, the bottom screw is for open adjustment.
- Loosen the open adjustment screw and turn hand-wheel until the valve disc is in fully opened position.
- Carefully re-tighten the open adjustment screw.
- Replace the outer set screw.



Figure 3

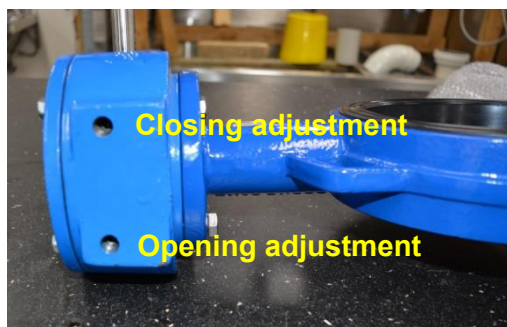

Figure 4

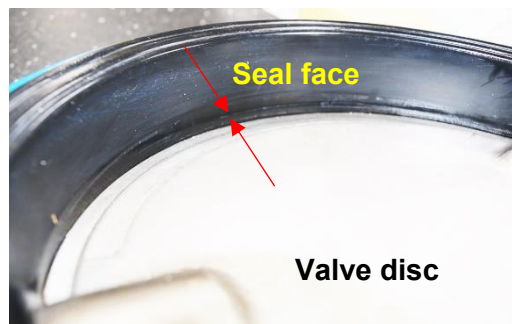

Figure 5



Gear Operator Installation Instruction

Lubrication:

These instructions are to be used when servicing the gear operator. Proper lubrication maintenance is necessary if unit is slow to operate or noisy, to ensure smooth operation and long service life of the unit. Failure to maintain the unit properly may lead to loss of performance or premature failure of the unit.

1. Lubricant:

Petroleum based lubricant/grease

2. Application:

- Remove 4 bolts and 2 screws to remove housing cover and indicator plate (**See Figure 6**)
- **Worm shaft**
Apply generous amount of grease to coat the entire worm shaft inside the housing. (**See Figure 7**)
- **Worm gear**
Apply grease into the worm gear teeth. After applying the grease, rotate the worm gear for at least 2 complete cycles, check even layer of grease and re-apply more grease if necessary. (**See Figure 7**)
- Replace 4 bolts and 2 screws to install housing cover and indicator plate.

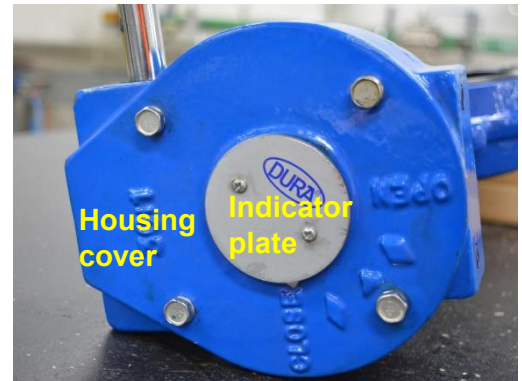

Figure 6



Figure 7