



## Shower Bath Mixer Installation Instructions

### GENERAL INFORMATION

- Pressure reducing valves should be installed, if either pressure exceeds maximum stated below.
- It is recommended that isolation stop taps are fitted to the inlet connections of the mixer.
- Brazed connections should NOT be made directly onto mixer, as excessive heat will cause permanent damage.
- All pipework must be thoroughly flushed prior to installation of the mixer.

#### Unequal Pressure Systems

- See specifications stated below.
- A 450mm length of straight pipe must run from the mixer outlet before any bend occurs.
- Line strainers should be installed in both the hot and cold water supply lines. (Foreign bodies could block the small hole in the cold water Venturi action nozzle)
- Install mixer as supplied.

#### Equal Pressure Systems

- See specifications stated below.

2. Fit cover plate (4) followed onto the mixer body (8), until cover plate abuts wall/tile face.
3. Fit handle (3) taking care that it is pushed fully down. Tighten grub screw (2) using the allen key (9) provided.
4. Turn on hot and cold water supply and check operation.

### REPLACING THE CARTRIDGE

1. Turn off hot and cold water supplies.
2. Using allen key (9) to loosen screw (2) and remove handle (3). Unscrew cap (5) taking care not to damage the decorative finish. Remove nut (6) then lift out cartridge (7).
3. Ensure inside of mixer body (8) is clean. Fit cartridge into mixer body, taking care that two lugs on base of cartridge fit into mating holes in mixer body.
4. Screw on nut (6). Important:- Nut (6) should be tightened to a torque of 11 Nm. Screw on cap (5).
5. Assembly of handle is a reversal of removal procedure.

### INSTALLATION

1. Mount the mixer body (8) to a suitable support timber in the wall and secure with screws.

When facing the mixer the connections should be:-

- Hot Water inlet connection 'H' to the left.
- Cold Water inlet connection 'C', to the right
- Mixed Water outlet connection, vertically upwards.
- Check all connections for leaks

Important:

- Mixer body (8) must be installed square to the wall/tile face to ensure cover plate (4) sits flush.

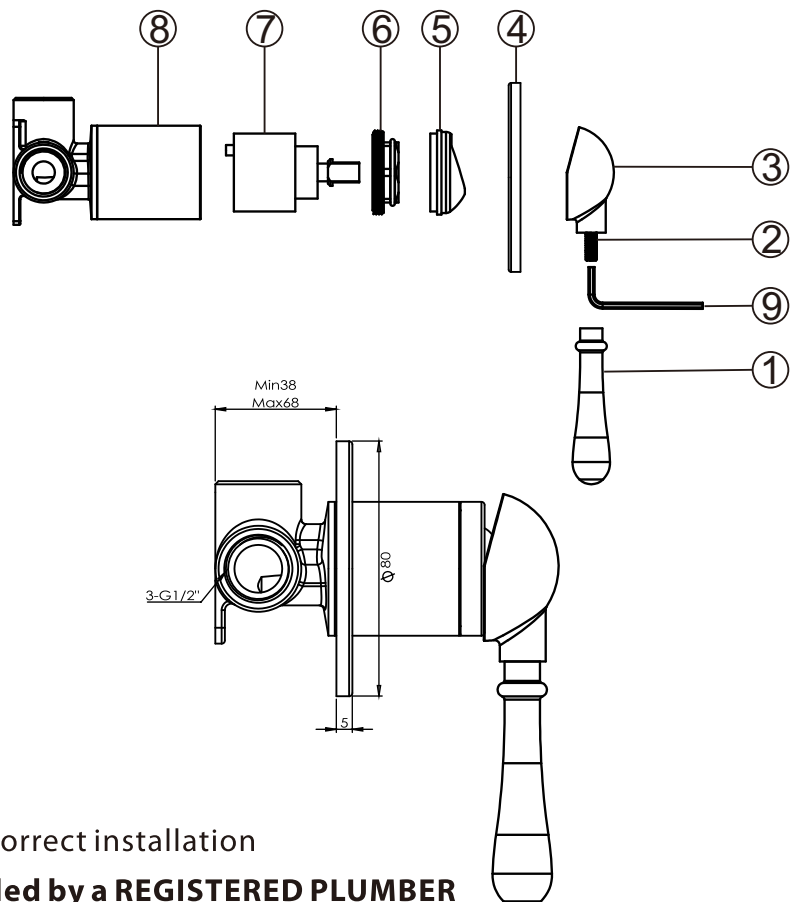

#### PRESSURE REQUIREMENTS

##### Unequal Pressure Systems

- Cold inlet pressure range 300 to 600 kPa
- Hot inlet pressure range 25 to 100 kPa
- Hot water temperature 55°C MIN / 80°C MAX

##### Equal Pressure Systems

- Cold inlet pressure range 300 to 600 kPa
- Hot inlet pressure range 300 to 600 kPa
- Hot water temperature 55°C MIN / 80°C MAX

Responsibility will not be accepted for incorrect installation of this Tapware, or any Tapware **not installed by a REGISTERED PLUMBER**

Plumbers, please ensure a copy of the installation instructions is left with the end user for future reference.