

HORIZONTAL MULTISTAGE PUMP INSTALLATION MANUAL



**A smooth day is a good day.
That's why Vada is dedicated
to creating pump solutions
that you can count on. With
a focus on easy selection, simple
installation and high quality, you
can hold your head high knowing
your reputation is protected.
It's Vada. Performance simplified.**

THANK YOU



Thank you for purchasing the Vada Flow Boss Horizontal Multistage Pump VFB-HM110! Record the product details here and leave with the owner.

Date purchased:

Purchased from:

Purchase invoice number:

Product serial number:

Product model number:



KNOW YOUR PRODUCT

VFB-HM110

The Vada Flow Boss VFB-HM110 is a self-priming Horizontal Multistage Pump that combines the functional benefits of a centrifugal pump and the practical benefits of a self-priming pump.

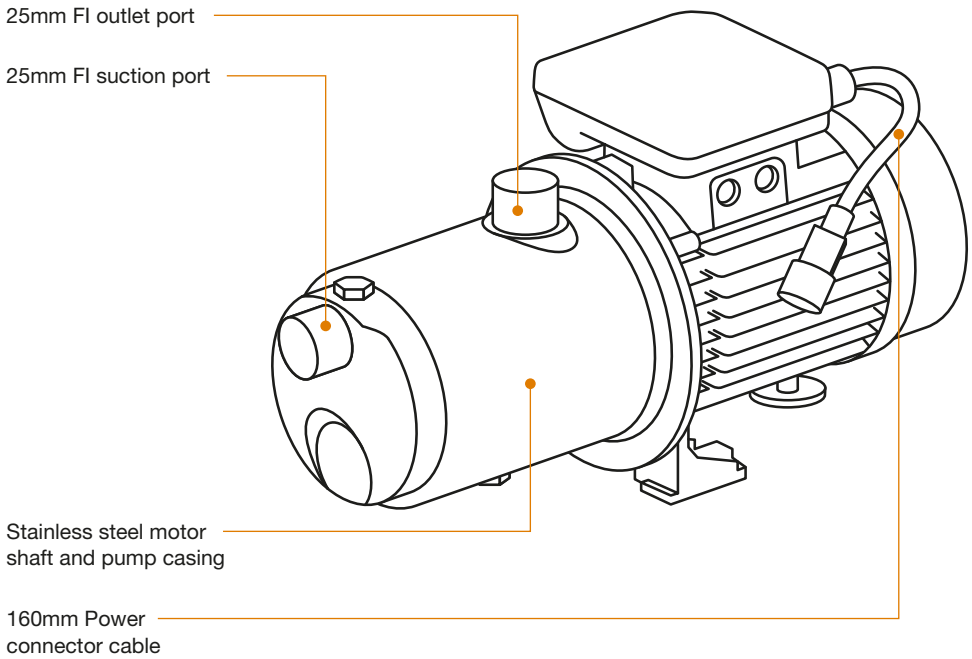

- Optimal operating range: 33–44 metres head, 40–60 litres per minute
- Max liquid temp: 50°C
- Max ambient temp: 40°C
- IP55 (Motor)

HELPFUL HINTS

- Use a pipe size with a minimum of 25mm internal diameter to reduce friction loss.
- Install a check valve or foot valve on the suction line for enhanced operation.

COMPATIBLE VADA PRODUCTS:

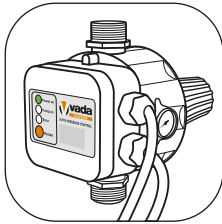

- Vada Flow Boss Automatic Pressure Control VFB-APC



- Vada Flow Boss Digital Water Switching Unit VFB-DSU



- Vada Flow Boss Mechanical Water Switching Unit 25mm VFB-MSU25

If your application is using tank water only, please install your Horizontal Multistage Pump with a Vada Flow Boss Automatic Pressure Control.

If you're using tank and mains water and require a switching unit, you can choose between the Auto Pressure Control and the Mechanical Switching Unit or the Digital Water Switching Unit.

KNOW YOUR PRODUCT

VFB-APC

The Vada Flow Boss Auto Pressure Control VFB-APC gives you perfect control of household pressure pumps, guaranteed. Designed with an LED light panel to signal the state of operation, a built in pressure gauge to allow for adjustable cut-in pressure and a 24 hour reset function for hassle free operation.

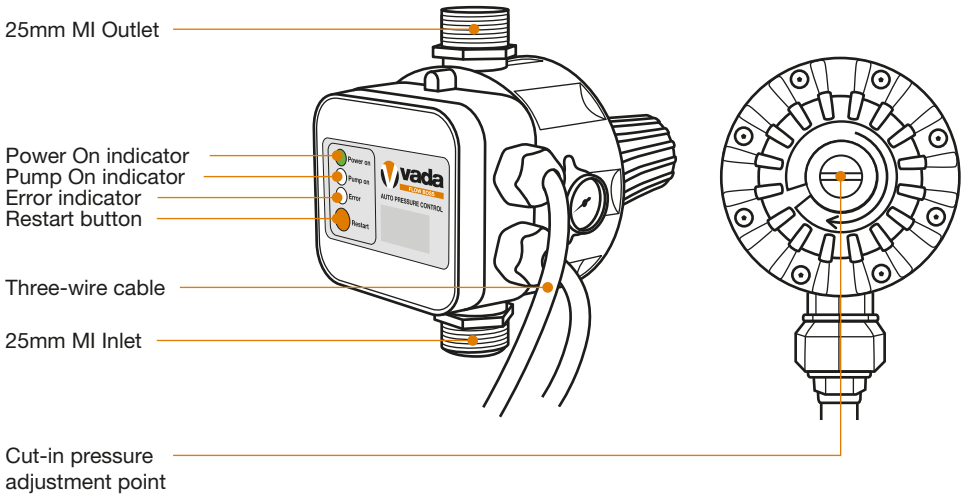

SPECIFICATIONS

VFB-APC

- Pump inlet: 25mm MI
- Pump outlet: 25mm MI
- Max water temp: 65°C
- Minimum pump pressure: 250kPa / 2.5 bar
- Maximum operating pressure: 1000kPa / 10 bar

HELPFUL HINTS

- You will need a flathead screwdriver if adjusting the cut-in pressure.
- Ensure your pump set up is equipped with two isolation valves. This allows for fuss free troubleshooting the suction and discharge lines, should you need it.

Green light

The VFB-APC is successfully connected to the power supply.

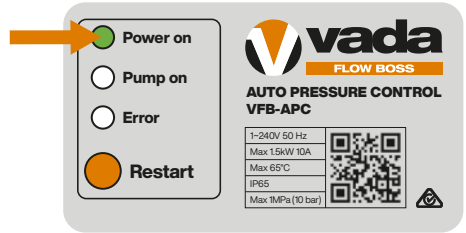

Yellow light

The pump is in operation.

Note: On initial start up the pump will run until the supply line is primed to remove all air.

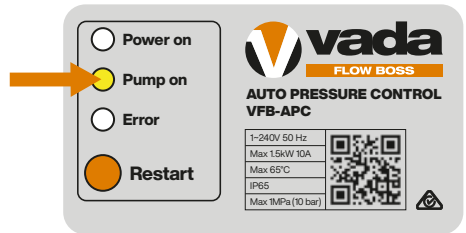

Red light

Flashing red: Loss of flow detected. While the red light is flashing, the pump will remain on for 20 seconds, then turn off as it tries to re-prime itself. It will attempt this several times.

Solid red: The pump has not been able to detect water and cannot re-prime itself. The pump will turn off for 24 hours, or until reset.

To reset, turn the power off, then on or press the restart button.

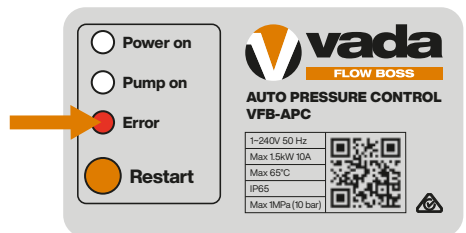

KNOW YOUR PRODUCT

VFB-MSU25

The Vada Flow Boss Mechanical Water Switching Unit VFB-MSU25 is a fully automatic mechanical unit that switches between tank and mains water. This device is designed for pressure pump supply systems, and allows you to harvest rainwater for the toilet, laundry, and other household applications with automatic mains backup.

The 25mm Switching Unit is suitable for up to 3 toilets, a washing machine, and an additional tap outlet including irrigation.

The Vada Flow Boss Mechanical Switch is suitable for clean water only.

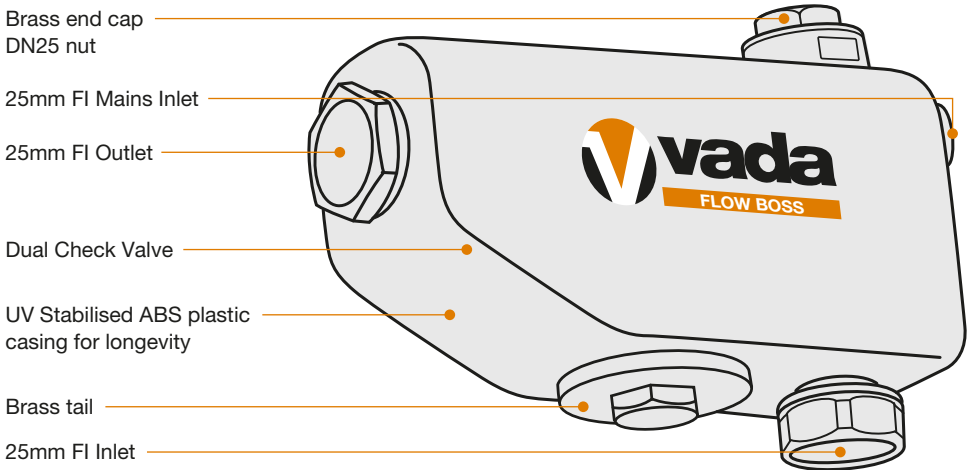

SPECIFICATIONS

VFB-MSU25

- Pump inlet: 25mm FI
- Mains water in: 25mm FI
- Outlet: 25mm FI
- Max mains pressure: 1000kPa / 10 bar
- Min pump pressure: 350kPa / 3.5 bar
- Max flow rate: 100 litres per minute
- Max water temp: 50°C

The Vada Flow Boss Digital Water Switching Unit VFB-DSU allows for water source switching between tank and mains water. With a large interactive panel, the VFB-DSU provides system information including a log of rain water used, real time flow rate, water pressure, current and error conditions.

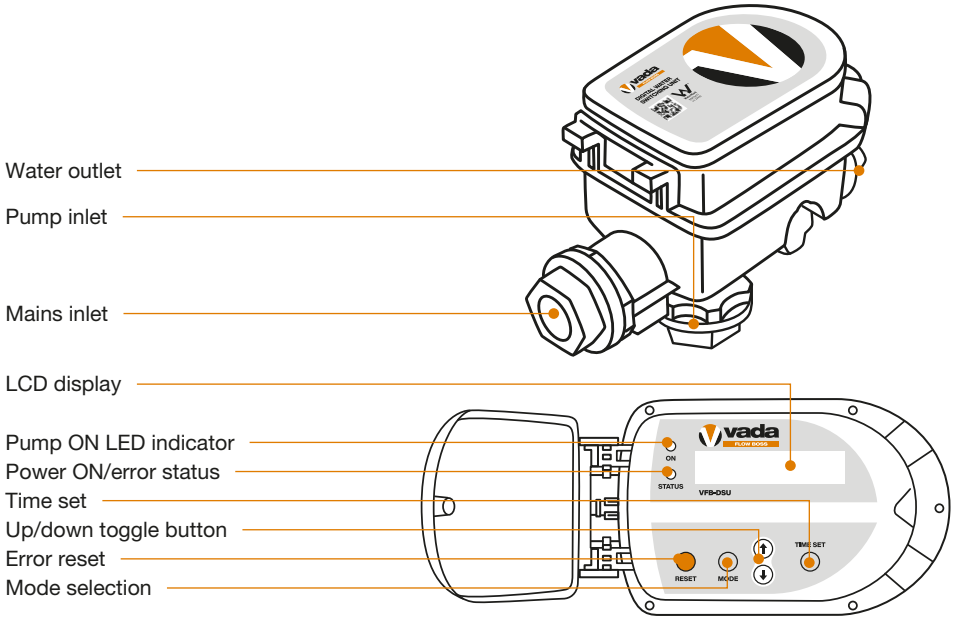

SPECIFICATIONS

VFB-DSU

- Mains water supply inlet: 25mm FI
- Pump connection: 25mm FI
- Water outlet connection: 25mm FI
- Minimum mains pressure: 100kPA / 1 bar
- Max operating pressure: 1000kPA / 10 bar
- Minimum flow rate: 1 lpm
- Voltage: 1~230–240V 50Hz
- Maximum electrical load: 10A / 2400W
- IP Rating: IP44

HELPFUL HINT

- View the complete Digital Water Switch Manual for further details on set up, operation and even troubleshooting.

APPLICATIONS

The Vada Flow Boss Horizontal Multistage Pump VFB-HM110 is suitable for the following applications:

Water source switching (tank/main)	Domestic pressure systems	Water transfer (clean water only)	Irrigation systems
✓	✓	✓	✓

The Vada Flow Boss Horizontal Multistage Pump VFB-HM110 is not suitable for the following applications:

Drainage of stormwater pits	Pumping of blackwater (wastewater with toilet discharge)	Pumping liquids containing long fibrous materials	Pumping aggressive or inflammable liquids	Pumping liquid containing abrasive solids (stones, ceramics etc.)
✗	✗	✗	✗	✗

INSTALLATION

PREPARING FOR INSTALLATION

For a successful installation, ensure you have all pieces listed below.

Vada Flow Boss Horizontal Multistage Pump VFB-HM110

What we've supplied:

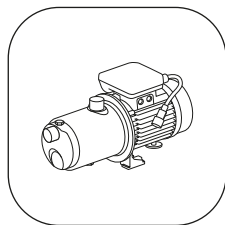

□ Vada Flow
Boss Horizontal
Multistage Pump
VFB-HM110

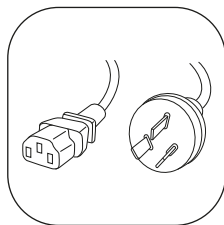

□ Power cable

INSTALLATION



What you'll need to supply:

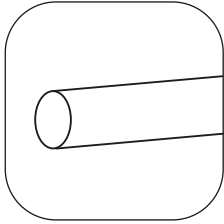

- Suction Pipe
(internal diameter
of 25mm or larger)

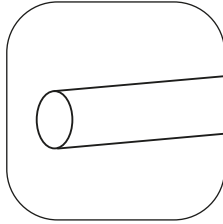

- Discharge pipe
(internal diameter
of 25mm or larger)

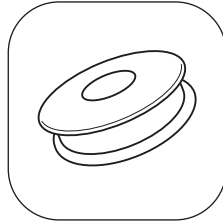

- Thread tape

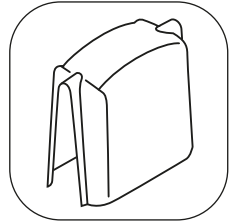

- Pump cover

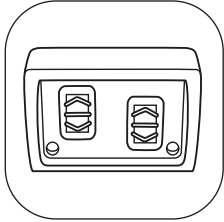

- Access to a 10A
outdoor power point

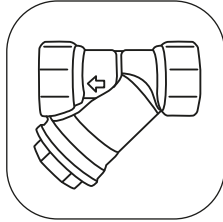

- Inline strainer aka
Y strainer

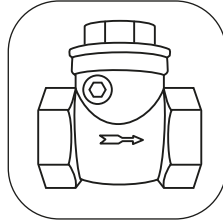

- Check valve

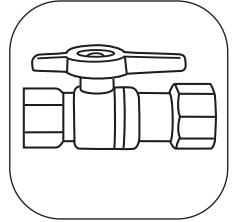

- x2 Isolation valves

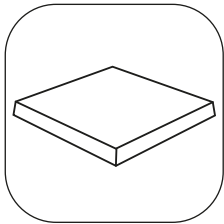

- Pump slab

- The residence must also have a Residual Current Device (RCD), also known as Electrical Leakage Circuit Breaker (ELCB). This is a safety switch located in the Fuse Box.

INSTALLATION

Vada Flow Boss Automatic Pressure Control VFB-APC

What we've supplied:



- Vada Flow Boss Automatic Pressure Control VFB-APC

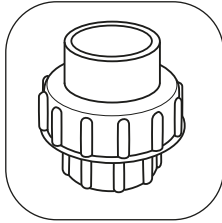

- 25mm barrel union

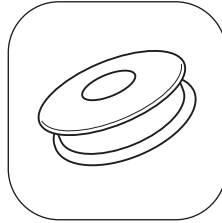

- Thread tape

Vada Flow Boss Mechanical Water Switching Unit VFB-MSU25

What we've supplied:



- Vada Flow Boss Mechanical Water Switching Unit 25mm VFB-MSU25

What you'll need to supply:



- Vada Flow Boss Automatic Pressure Control VFB-APC



Vada Flow Boss Digital Water Switching Unit VFB-DSU

What we've supplied:



- Vada Flow Boss Digital Water Switching Unit VFB-DSU

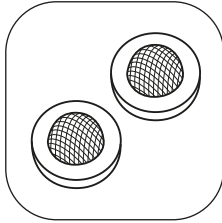

- x2 mesh washer inline filters

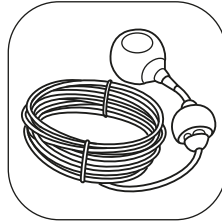

- Float switch kit

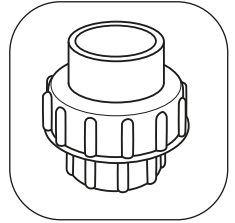

- Barrel union kit

What you'll need to supply:

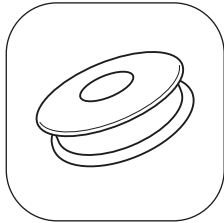

- Teflon tape

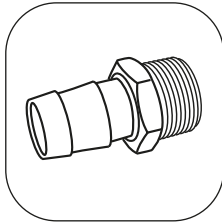

- 25mm or larger male hose barb

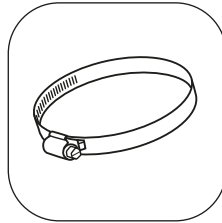

- Hose clamps

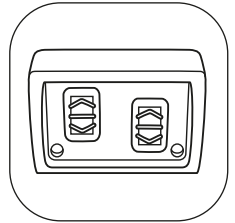

- Access to a 10A outdoor powerpoint

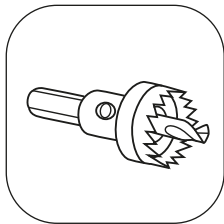

- 16mm hole saw (to drill hole in roof tank for float switch cable)

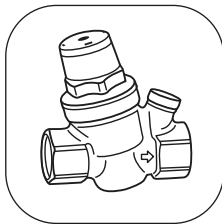

- Pressure reduction valve*

*If the incoming mains pressure to your property is greater than the specified 1000 kPa (10 bar), you MUST fit a pressure reduction valve of appropriate capacity upstream of the VFB-DSU. The recommended pressure is 500kPa as per AS/NZS 3500.

INSTALLATION

PART 1: PUMP LOCATION

Let's get down to business.

Note: Ensure the pump is being installed by a qualified, licensed personnel. The pump should be in good condition and should be used in a residential application.

Note: The length and the diameter of the discharge pipe impacts the pressure and flow rate the VFB-HM110 can deliver.

Note: all components used must have a pressure rating that exceeds the maximum pressure of the pump by an appropriate safety factor.



In accordance with AS 3350.2.41 we are obliged to inform you that this pump is not to be used by children or infirm persons and must not be used as a toy by children.



Ensure that the power lead remains disconnected until you have completed the installation process.



The Auto Pressure Control is pre-set by the manufacturer with a pump start pressure of 1.5 bar (this can be adjusted). The maximum pump pressure must be 0.8 bar above the start pressure for the pump to reach automatic shut-off.



The Pressure Control has a safety valve preventing water emission in case of diaphragm damage. DO NOT REMOVE.

1. Ensure you have access to a 10A weatherproof outdoor powerpoint in a dry and flood free location. Do not plug the power cable in.

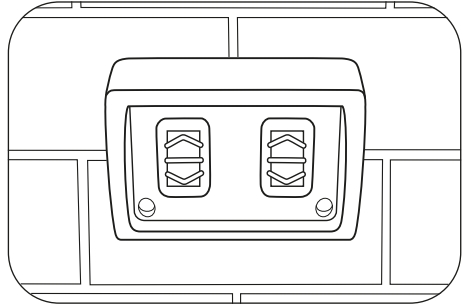

Note: If you do not have access, arrange an electrician to install one.

2. Find a location for your pump as close to your water source as possible. Use either a poly, or concrete base slab to mount the pump. This location should be stable, dry and on a separate footing from your home.

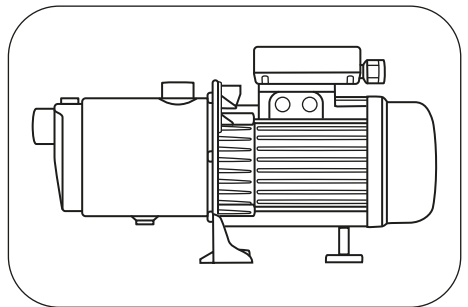

Note: It is recommended the pump should be no further than 3 metres from the tank.



PART 2: SUCTION SET UP

Now that your Horizontal Multistage Pump is positioned, it's time to set up the suction pipework. This will run from your tank/water source to your pump.

1. Select pipe that is re-enforced and crush resistant (non-collapsible), with an internal diameter of 25mm or larger.

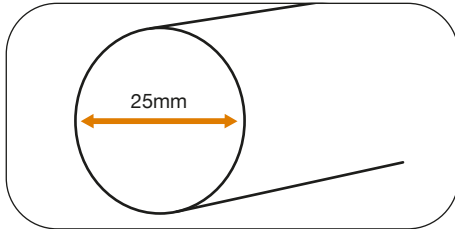

2. Install an isolation valve at the tank/water source outlet.

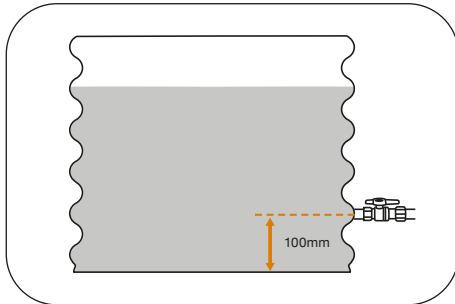

3. If the tank is below ground, install a foot valve at the point of entry on the suction line.

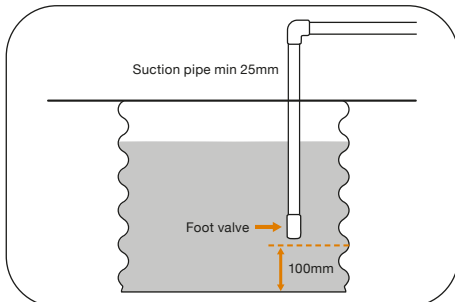

4. Connect the suction pipe to your Horizontal Multistage Pump. Ensuring both an inline filter and barrel union have been installed in the suction line. The inline filter prevents dirt and debris entering the pump and will prolong product lifespan.

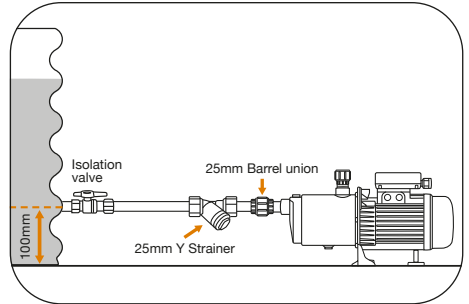

Note: The length of the suction pipe should only run between 1–2 metres.

Note: Install a check valve for optimal performance should the tank be above ground but lower in elevation than the suction inlet of the pump.

5. Check that all fittings connected to the suction pipe are airtight.



INSTALLATION

PART 3: DISCHARGE SET UP

Now that your suction pipework is installed, it's time to set up the discharge pipework.

1. Select a pipe with an internal diameter of 25mm or larger (this is the size of the discharge outlet port).

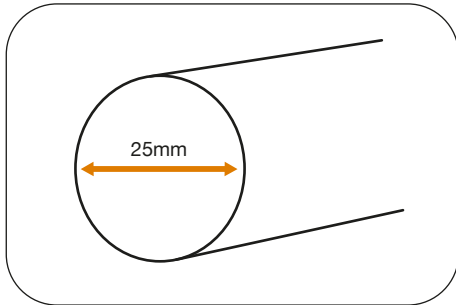

2. Connect the pipe to the Horizontal Multistage Pump using a 25mm barrel union.

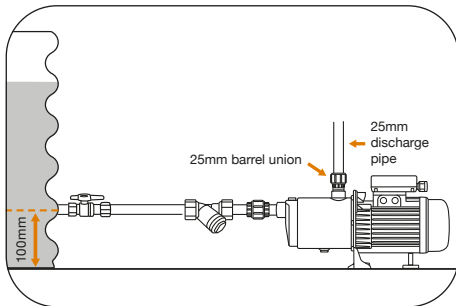

Note: It is crucial that you use the recommended pipe size until at least the first pipe branch (T piece) is reached.

PART 4: PUMP PRIMING

Before moving on, it's important to prime the pump. This means filling the pump with water and expelling all air from within the pump casing.

If you've set up a surface mount pump, follow steps outlined in Part 4A.

If you've set up a pump mounted above a tank, follow steps outlined in Part 4B.

PART 4A: PRIMING A SURFACE MOUNT PUMP AND TANK

1. Ensure the water level in your tank sits above the tank outlet. This will ensure the pump does not draw in any air during priming.

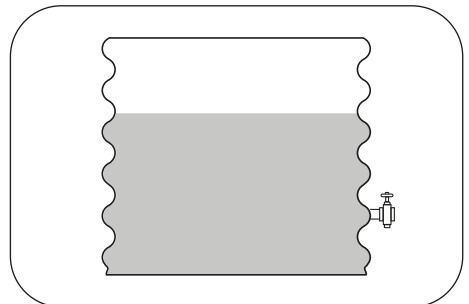

2. Open the isolation valve on the tank. If there are any leaks, repair these immediately. If no leaks are present, proceed.

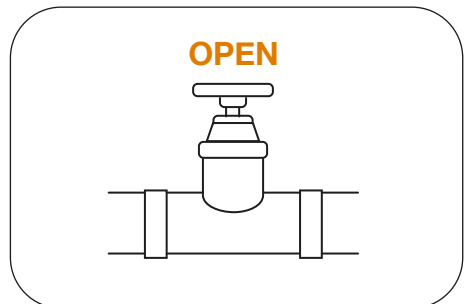



3. Close the tank isolation valve and then remove the priming port plug on the top of the pump casing.

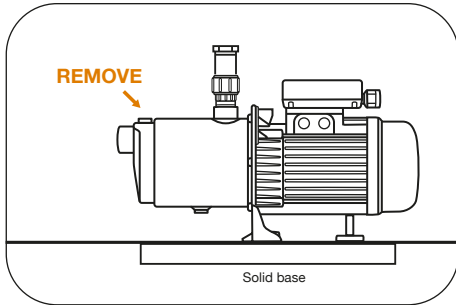

4. Slowly open the tank isolation valve allowing water to fill the suction line and pump casing. This will expel the air as the water fills the suction line and pump casing.

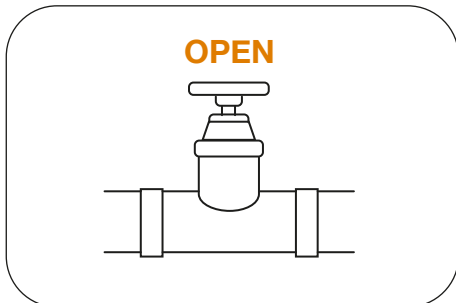

5. Once all air is expelled a steady stream of water will trickle out.

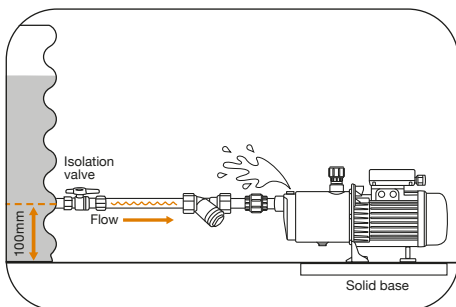

6. Close the isolation valve and replace the priming port plug. The isolation valve must be re-opened prior to operation. Your pump is now primed. Before pump operation ensure there is sufficient water inside the tank.

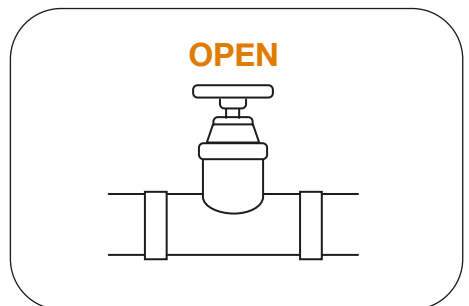
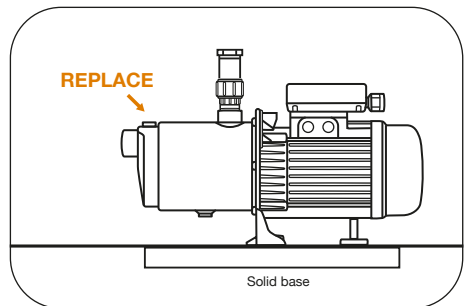
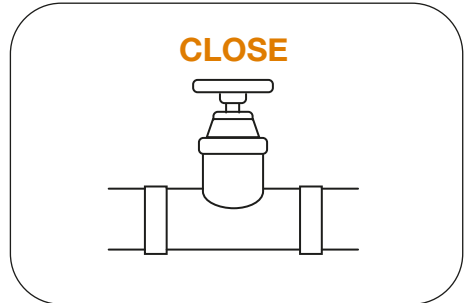

INSTALLATION

PART 4B: PRIMING A PUMP MOUNTED ABOVE A TANK

1. Ensure a foot valve or non-return valve is fitted to the end of the suction line.

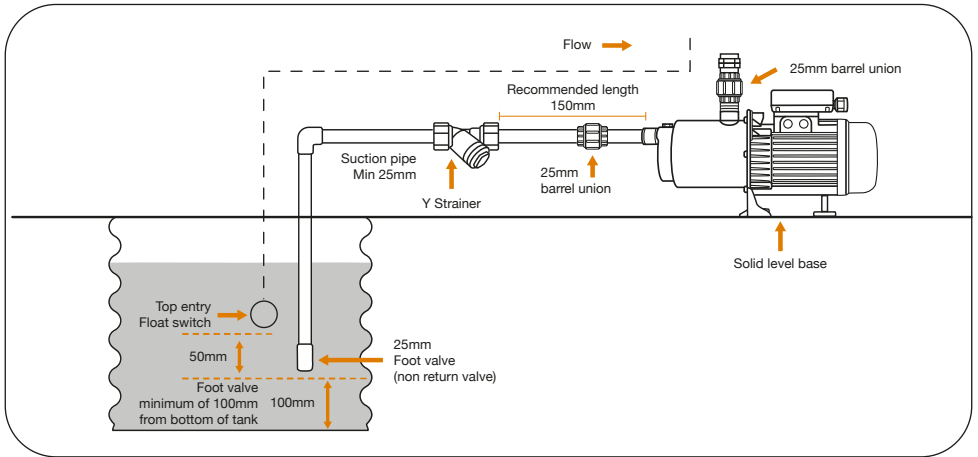

2. Remove the priming port plug on the top of the pump casing.

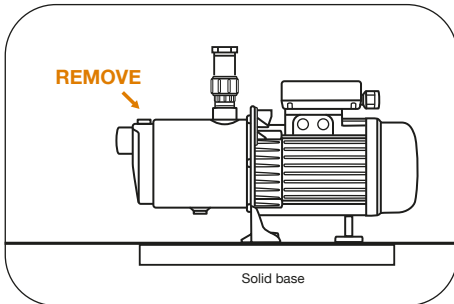

3. Slowly fill the pump casing and suction line with water through the priming port (best done with a funnel) allowing air to vent as the water fills the suction line and pump casing. If there are any leaks, repair these immediately. If no leaks are present, proceed.

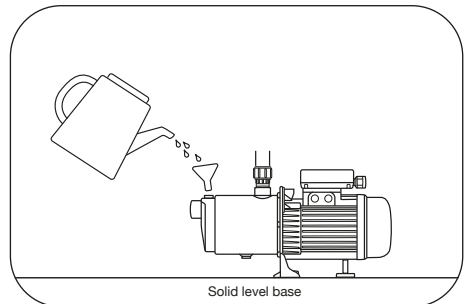



4. Once the suction line and pump casing are full of water and all air is expelled, replace the priming port plug. Your pump is now primed. Before pump operation ensure there is sufficient water inside the tank.

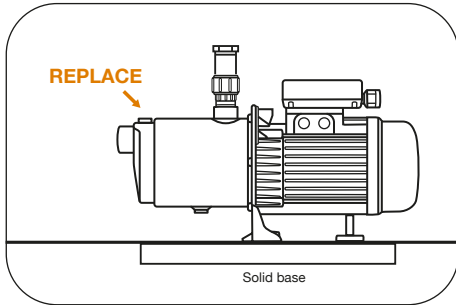

PART 5: FIT A VADA FLOW BOSS AUTO PRESSURE CONTROL.

If you are installing the Vada Flow Boss Digital Water Switch for a tank/mains application, skip to Installation Part 7 on page 23.



Never take the electronic board out of the control box. The wiring diagram inside the front panel will show you how to make correct connection. Wrong connection will destroy the whole electronic circuit.



If extending the cable used for connection, ensure the connection is being carried out by a qualified professional with an electrical license.

1. Keep the VFB-APC unplugged from the power source.

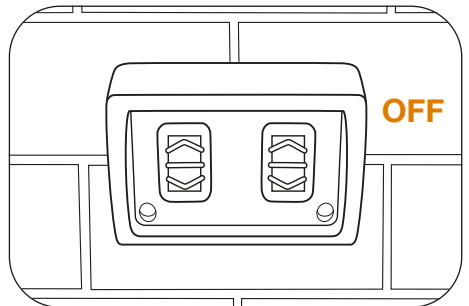

INSTALLATION

2. Position the Auto Pressure Control (VFB-APC) between the pump and the first outlet.

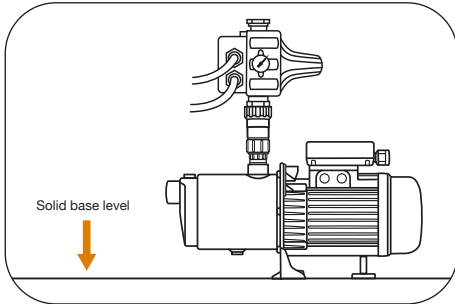

Note: If you are installing the VFB-APC directly onto the Horizontal Multistage Pump, use a 25mm barrel union. If you are installing the VFB-APC between the pump and first outlet, use pipework with a minimum internal diameter of 25mm.

Note: Do not install an outlet between the pump and VFB-APC.

Note: the pipe must have an internal diameter no smaller than 25mm until the first tee branch.

3. Ensure the VFB-APC is installed with the arrows pointing up.

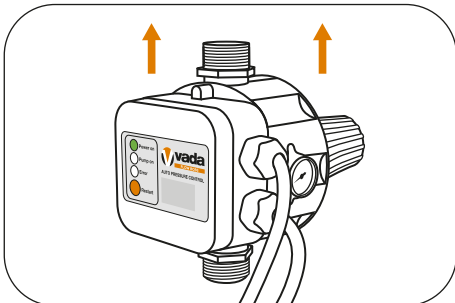

4. Check the set up so far. Ensure that the VFB-APC is braced or fixed so minimal movement occurs once in operation. If the distance between the pump and highest outlet exceeds 15m, adjust the cut-in pressure on the VFB-APC.

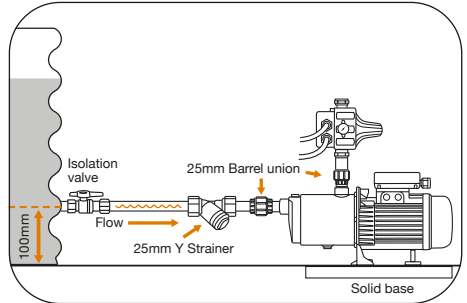

PART 6: FIT A VADA FLOW BOSS MECHANICAL WATER SWITCHING UNIT 25MM

Follow these steps if you are installing a Vada Flow Boss Mechanical Switch for a tank/ mains system.

1. Grab the rubber washer supplied and place it on top of the Auto Pressure Control (VFB-APC) outlet.

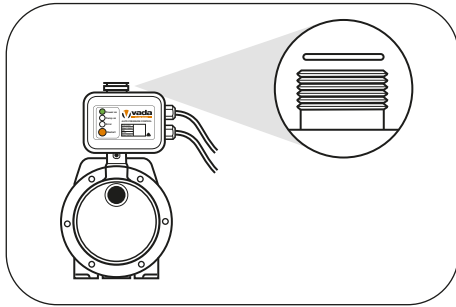

2. Hold the Mechanical Switching Unit (VFB-MSU25) over the outlet and connect the loose nut. Do not overtighten. The rubber washer will lock this in place.

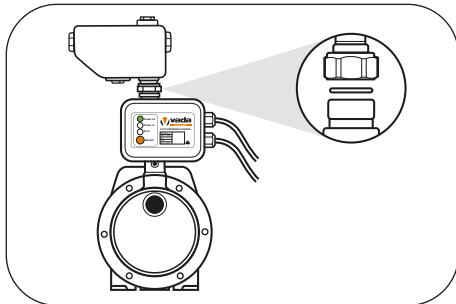

3. Connect the mains water pipe to the VFB-MSU25 outlet labelled "mains in".

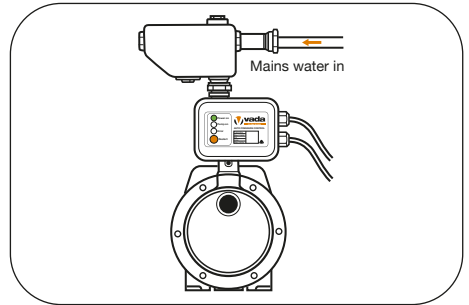

4. Connect the house water pipe to the VFB-MSU25 outlet labelled "to house".

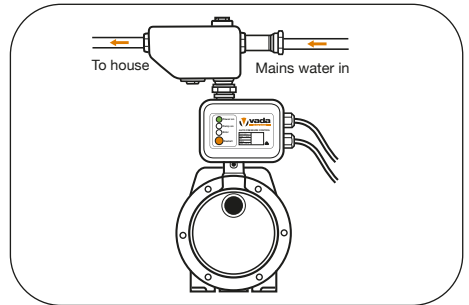

5. For easy maintenance down the track, install an isolation valve into both the mains and house water line.

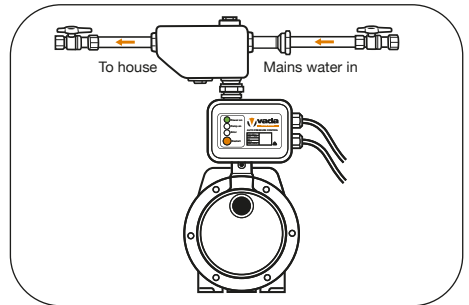

INSTALLATION

Adjust the Cut-In Pressure

After installing the VFB-APC and VFB-MSU25, the cut-in pressure must be adjusted to ensure a smooth and reliable changeover.

1. Turn on the Pump and VFB-APC.

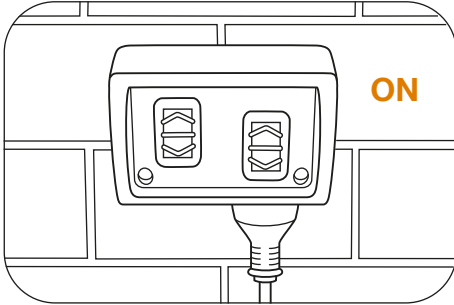

2. Locate the adjustment screw at the back of the VFB-APC.

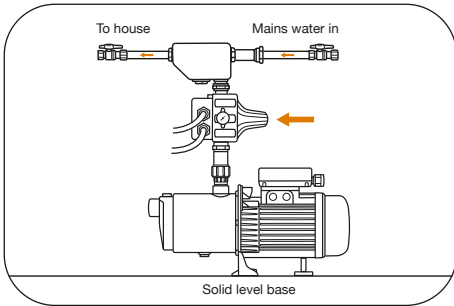

3. Using a flat head screwdriver, turn the adjustment screw clockwise until you reach the correct pressure (roughly, this will be 3.5 full 360° turns).

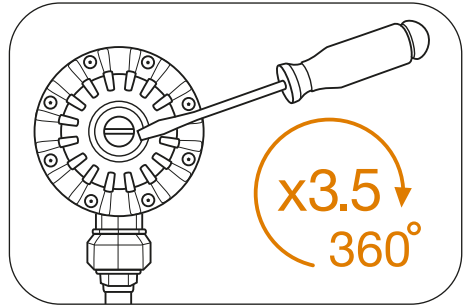

4. Confirm the pressure has been correctly adjusted by slowly opening an outlet and checking the gauge on the side of the VFB-APC. If the pump starts when the gauge drops to 2.2 bar the cut in pressure has been successfully adjusted.

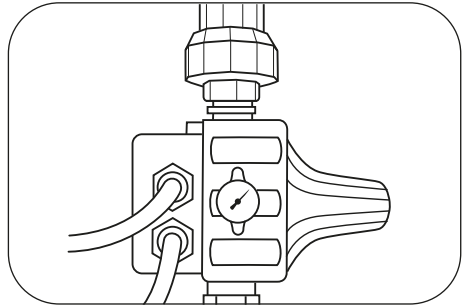

5. Your pump solution is now ready of operation!





PART 7: CONNECTING THE DIGITAL WATER SWITCHING UNIT TO THE PUMP

1. Wrap thread tape around both ends of a 25mm nipple.

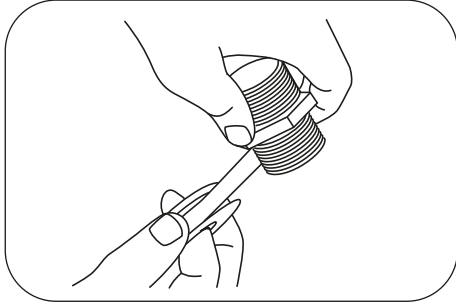

2. Thread the nipple into the female socket of the pump discharge until it is watertight. Do not overtighten.

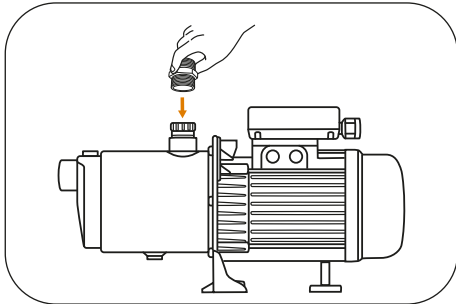

3. Connect the 25mm female end of the barrel union to the nipple until it is watertight. Do not overtighten.

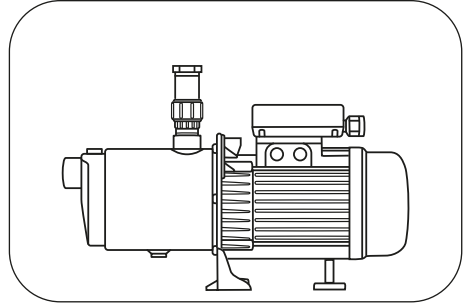

4. Wrap thread seal tape around another 25mm nipple.

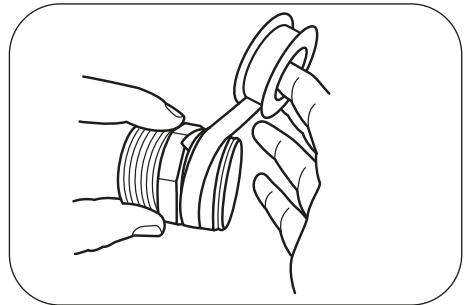

5. Thread the nipple into the base of the switching unit until it is watertight. Do not overtighten.

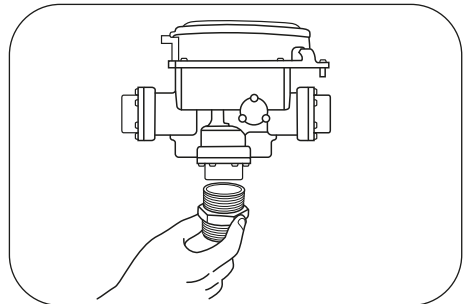

INSTALLATION

Note: If you cannot screw the switching unit on top of the barrel union due to space limitations, you can unscrew the barrel union nut and release the nipple from the union. Rethread the nipple into the switching unit making sure the union nut remains on the nipple. Re-join the union to complete connection.

6. Connect the VFB-DSU to the discharge port on the pump.

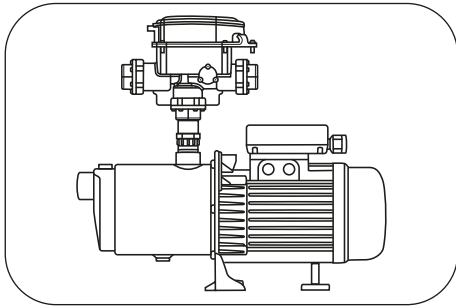

7. Connect the 25mm female end of the switching unit to the incoming mains water supply. This is marked 'MAINS' with an arrow pointing out of the VFB-DSU (indicating water flow direction).

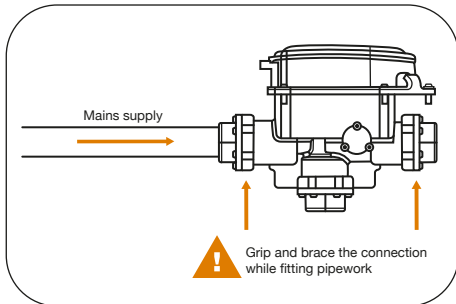

Note: Brace this fitting to prevent movement while connecting to the mains supply.

8. Connect the 25mm female end of the switching unit to the household plumbing supply. This is marked 'OUTLET' on the unit with an arrow pointing out of the unit (indicating water flow direction).

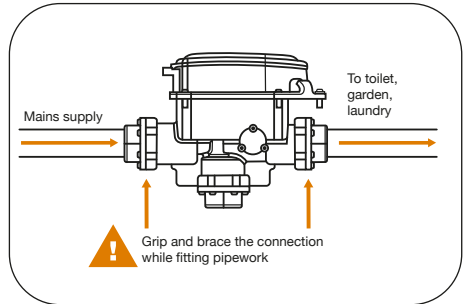

9. For easy maintenance install an isolation valve on either side of the VFB-DSU.

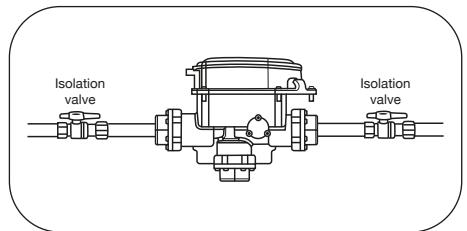

Note: Vada strongly recommends installing the float switch (supplied), in the tank on site. Installing a float switch prevents air from re-entering the suction line and damaging your Vada product. Installing a float switch also reduces build up from tank debris entering the pump.

For full installation instructions, refer to the Vada VFB-DSU manual.



Brace this fitting to prevent movement while connecting to the mains supply.



Movement of this fitting could disturb internal seals, causing leakage.



Pipe Marking

In accordance with AS/NZS 3500.1:2003, pipe and outlets connected to the Vada Digital Water Switching Unit must be marked as follows:

- Outlets connected to the unit must be marked with the wording "RAINWATER".
 - Piping systems connected the unit must be clearly marked at 1m spacings with the word "RAINWATER".
8. Install a pump cover to protect your set up from wind, rain, and sun.

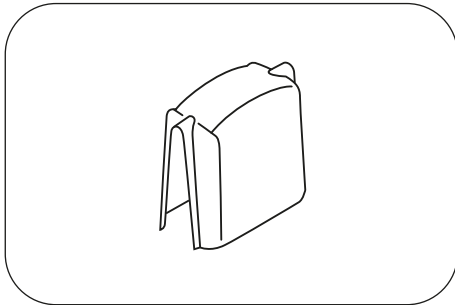

PART 8: CONNECT TO A POWER SUPPLY

1. Check that the powerpoint is located in a dry and flood free location.

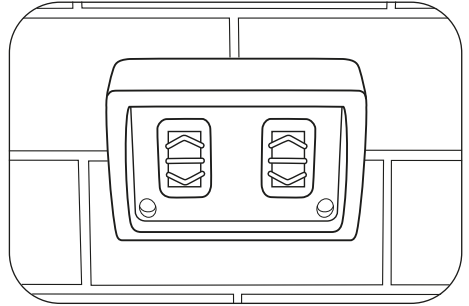

2. Ensure the power supply cord is supported by the delivery pipes at 3 metre intervals.

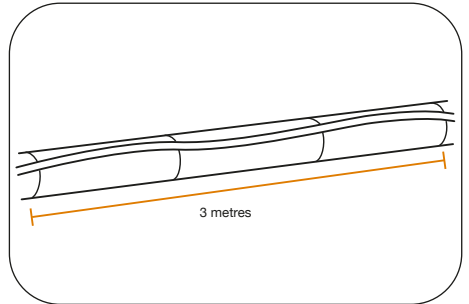

3. Ensure there are no water traces on the pump connectors. Push them firmly into each other to ensure intended splash (water) proof protection.

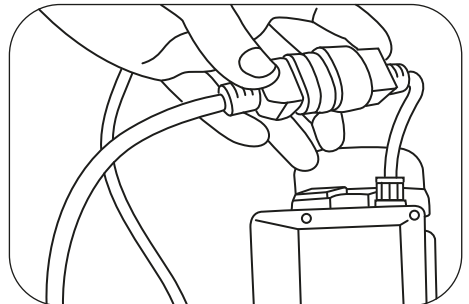

INSTALLATION

4. Connect the power lead to the power outlet. Do not turn on.

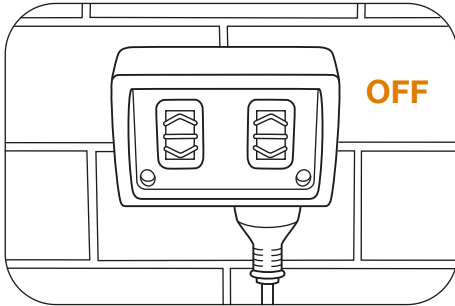

- a. If installing the Horizontal Multistage Pump by itself, simply connect the two supplied cords using the IEC socket and plug.
- b. If installing an VFB-APC or VFB-MSU25, connect the IEC socket from the pump to the IEC plug cord on the VFB-APC or VFB-DSU.

Note: Supply voltage that is outside the limits specified can cause the motor to overheat leading to overload tripping, reduced component life or seriously damage pump, voiding warranty.

Note: For additional protection, the pump must be supplied from an outlet protected by a residual current device – RCD (also known as an Electrical Leakage Circuit breaker – ELCB) with a maximum rated residual current of 30mA.

Note: Do not use extension cords. This can cause the voltage to drop.

FLOW BOSS SET UP OPTIONS



Set up 1: Above Ground Mechanical Water Source Switching

- Vada Flow Boss Horizontal Multistage Pump VFB-HM110
- Vada Flow Boss Auto Pressure Control VFB-APC
- Vada Flow Boss Mechanical Water Switching Unit 25mm VFB-MSU25

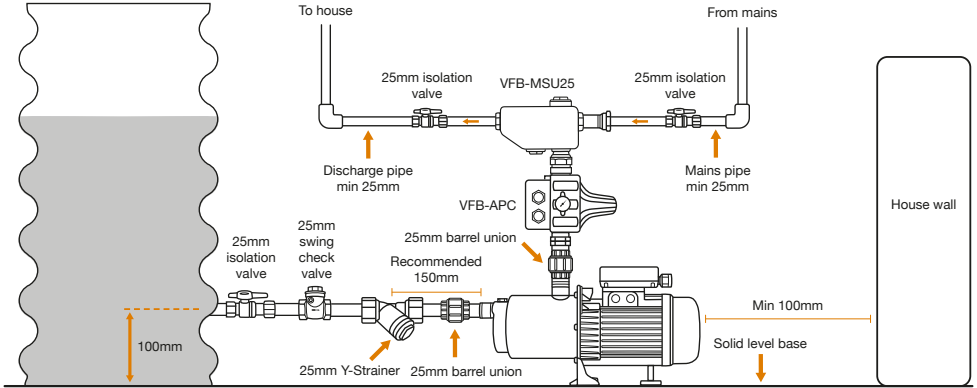

Set up 2: Below Ground Mechanical Water Source Switching

- Vada Flow Boss Horizontal Multistage Pump VFB-HM110
- Vada Flow Boss Auto Pressure Control VFB-APC
- Vada Flow Boss Mechanical Water Switching Unit 25mm VFB-MSU25

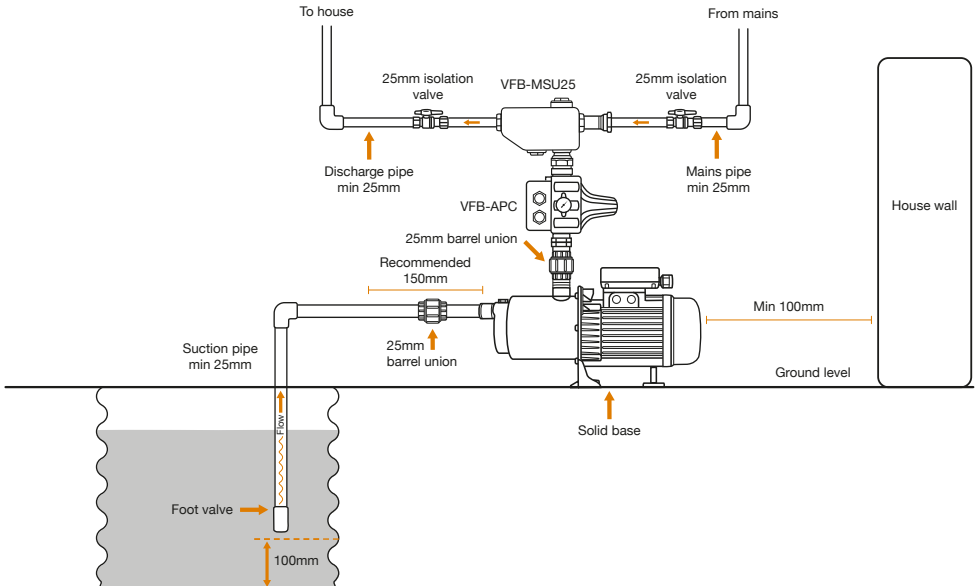

FLOW BOSS SET UP OPTIONS

Set up 3: Above Ground Digital Water Source Switching

- Vada Flow Boss Horizontal Multistage Pump VFB-HM110
- Vada Flow Boss Digital Water Switching Unit VFB-DSU

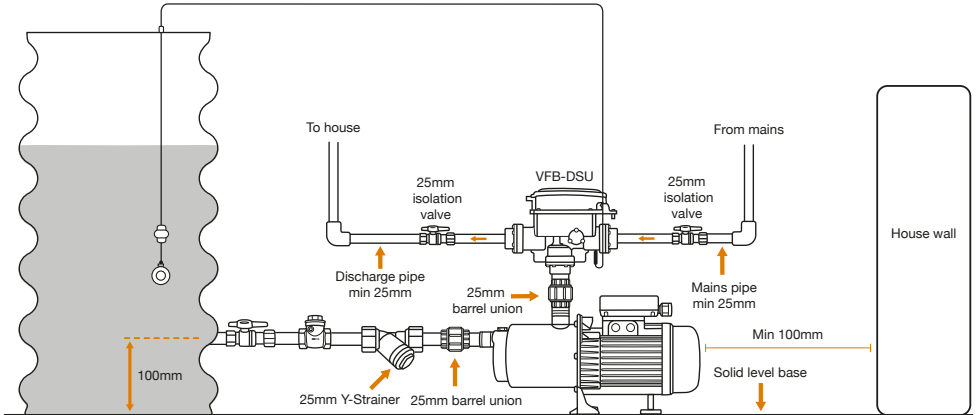

Set up 4: Above Ground Digital Water Source Switching

- Vada Flow Boss Horizontal Multistage Pump VFB-HM110
- Vada Flow Boss Digital Water Source Switching Unit VFB-DSU

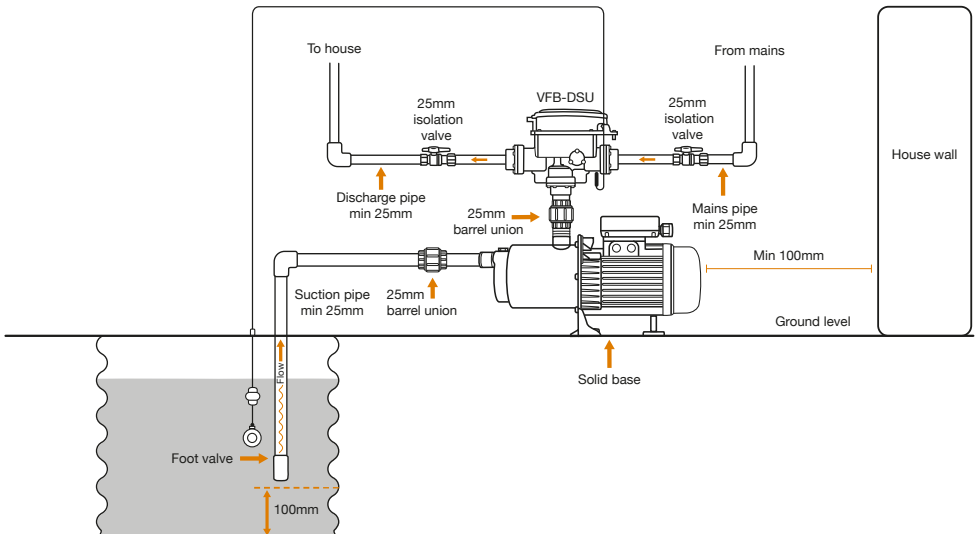

OPERATION



Horizontal Multistage Pump and Auto Pressure Control/Auto Pressure Control and Mechanical Water Switching Unit

Note: The following images show a set up with pump, VFB-APC and VFB-MSU, however these steps apply to all possible set ups.

Ensure that the pump has been successfully primed.

1. Open the gate valve on the suction line.

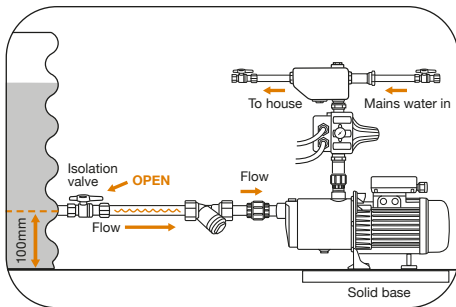

2. Slowly open the gate valve on the discharge line to 50%.

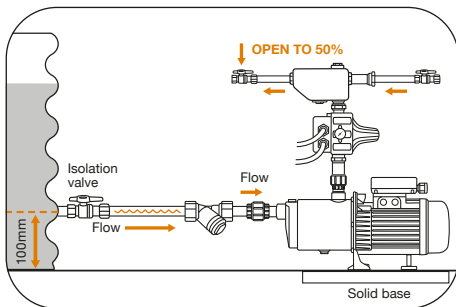

3. Turn the power on at the powerpoint.

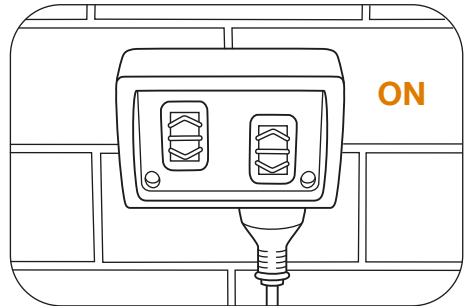

4. When the power is turned on the pump will start to pump water. If you're using an VFB-APC, the yellow "Pump On" LED on the Pressure Control will illuminate.

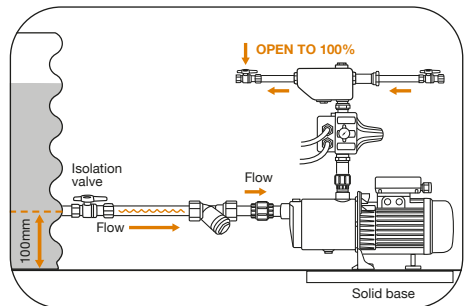

OPERATION

5. Open the outlet on discharge line and open isolation valve on the discharge line to 100%. This will assist with removal of unwanted air

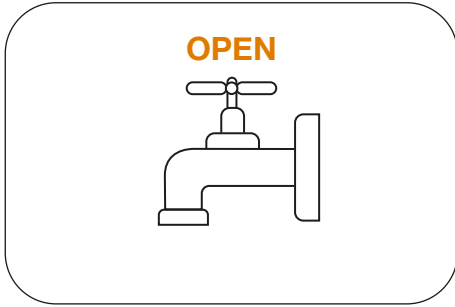

Note: without an VFB-APC or VFB-DSU the pump will continue to operate until the power is switched off.

Note: On initial start-up the pump will run until the discharge line is primed.

6. Once all pipework has been filled on the discharge side and tap/outlet side, turn off the tap.

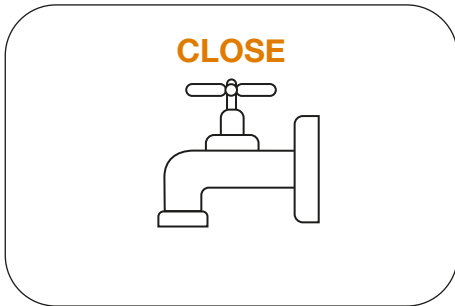

Note: The pump will run for a short period of time until the system is again pressurised and then stop.

7. The pump set up is now ready for use.



8. If no water is delivered, it may mean the pump has failed to prime. The pressure controller will indicate this by flashing red for 1 minute, as the pump continues to turn on, then off. After 1 minute, the VFB-APC will have detected the loss of prime and will go into a 24 hour lock out mode. To manually reset the VFB-APC, you can press the restart button.

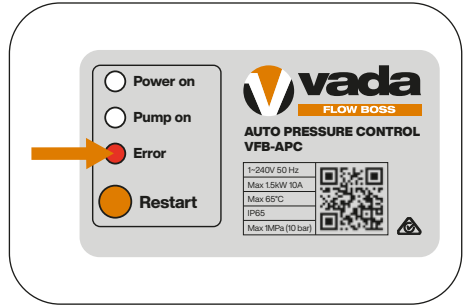

Horizontal Multistage Pump and Digital Water Switching Unit

For operating instructions, please refer to the complete Digital Water Switching Manual.





Turn off power to motor and remove plug from power outlet before working on pump or motor.



Liquid may be HOT, release pressure with care before servicing.



Pump should only be serviced by qualified personnel. For best results, use only genuine service parts. Be sure to prime pump before starting.

Under normal conditions, the Vada Flow Boss Horizontal Multistage Pump VFB-HM110 requires low maintenance and is simple to service.

To avoid possible failures, we recommend periodically checking the flow and pressure supplied and current absorption:

- A decrease in pressure is a symptom of wear.
- An increase in current absorption is a sign of abnormal mechanical friction in the pump and/or motor which may be caused by debris caught in the impeller.

Cleaning the in-line filter

To avoid a build-up of debris and dirt, Vada recommends cleaning out the in-line filter once every 6 months, or as required. To do so, follow the steps below.

1. Isolate all water supplies and remove the internal strainer.

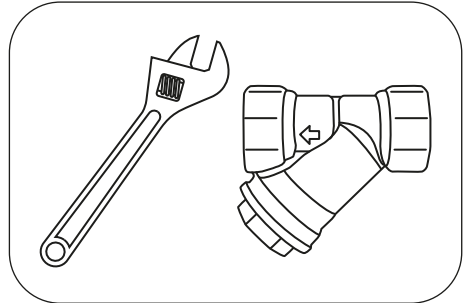

2. Use a steel brush to clean the dirt from the filter.

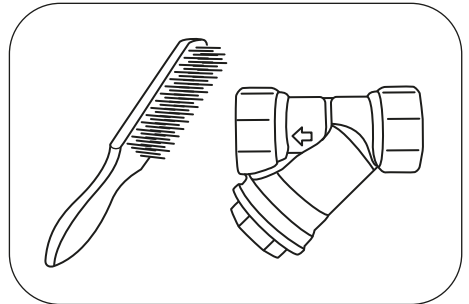

3. Rinse with clean water and reassemble.

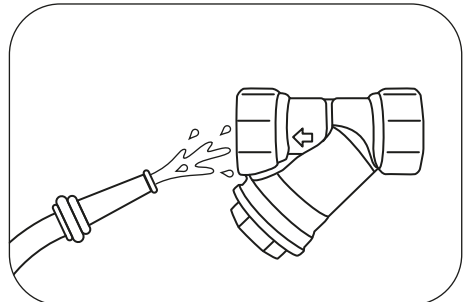

STORING THE PUMP

If the pump is not going to be used for long periods of time (e.g. 6 months), it should be emptied completely, rinsed with clean water and stored in a dry, shaded place.

PUMP PERFORMANCE CURVE

Pump curves are a great tool to understand your pumps performance capabilities. In relation to head (metres) and flow (litres per minute). Pump curves can be interpreted by tracing your finger along the head (metres) across to flow (litres per minute).

For example, in the pump performance curve below, you can see that if the Horizontal Multistage Pump VFB-HM110 has a discharge head between 33–44 metres, then the pump will produce 40–60 l/min.

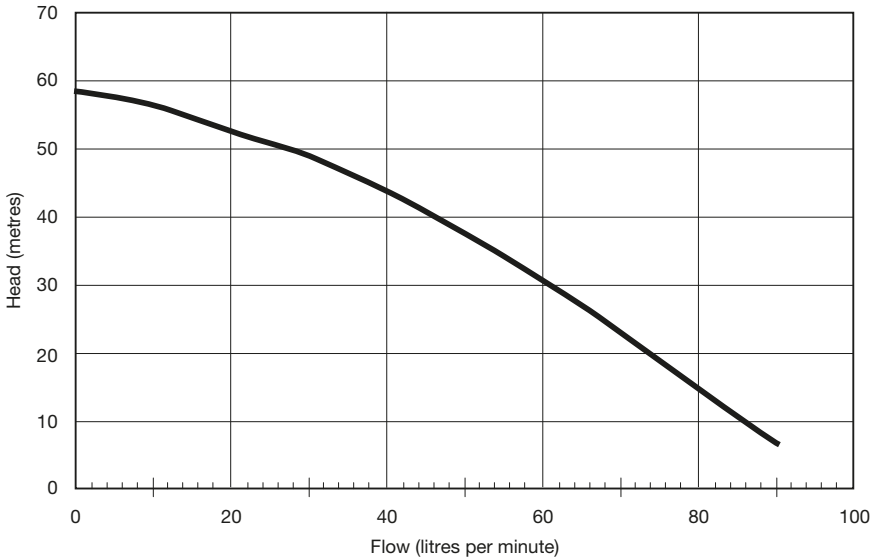

Note: The curve above represents the pump with the VFB-APC.

Note: Should you require more specific information on your application for working out the required discharge head or system duty, please contact a Reece specialty engineering or design business unit.

PRODUCT DIMENSIONS

- A. 422mm
- B. 162mm
- C. 129mm
- D. 180mm
- E. 177mm
- F. 207mm

Outlet port: 25mm FI
Suction port: 25mm FI
Weight: 9.7kg

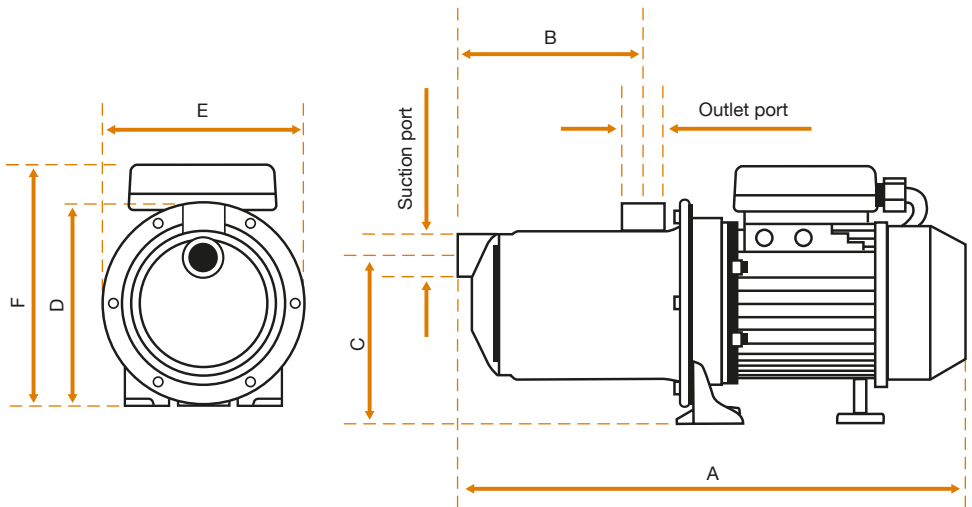

CONSTRUCTION	
Pump casing	X5 CrNi 1810 (AISI 304) stainless steel
Motor casing	Die-cast aluminium
Impeller	Fiberglass Reinforced PPO
Diffuser	Fiberglass Reinforced PPO
Shaft	X12 CrNiS 1809 (AISI 416) stainless steel
Mechanical seal	Carbon graphite/ NBR/AISI 304 SS
Counterface	Ceramic
Seal holder plate	Fiberglass Reinforced PPO
O-ring	Nitrile Butadiene Rubber 70

USAGE LIMITATIONS	
Liquid type	Clean water with no suspended solids or abrasive material
Max. liquid temp	50°C
Max. ambient temp	40°C
Min. ambient temp	0°C
Max. recommended suction height	8m
Max operating pressure	800kPa / 8 bar

MOTOR	
IP rating	IP55 (motor)
Speed of rotation	2850rpm (motor)
Insulation	Class F (motor)
Enclosed, externally ventilated	
Capacitor permanently activated	
Thermal protection built into the motor winding	
Suitable for continuous use	

POWER		
Nominal power	HP	0.94
	kW	0.70
Absorbed power	HP	1.27
	kW	0.95
Voltage	1~230–240V 50Hz	
Full load amps	4.3	
µF	16	

Q	L/1'	10	20	30	40	50
	m3/h	0.6	1.2	1.8	2.4	3
Discharge in meters		56.5	53	48.5	42	35.5

PRODUCT DIMENSIONS

- A. 174mm
- B. 188mm
- C. 147mm

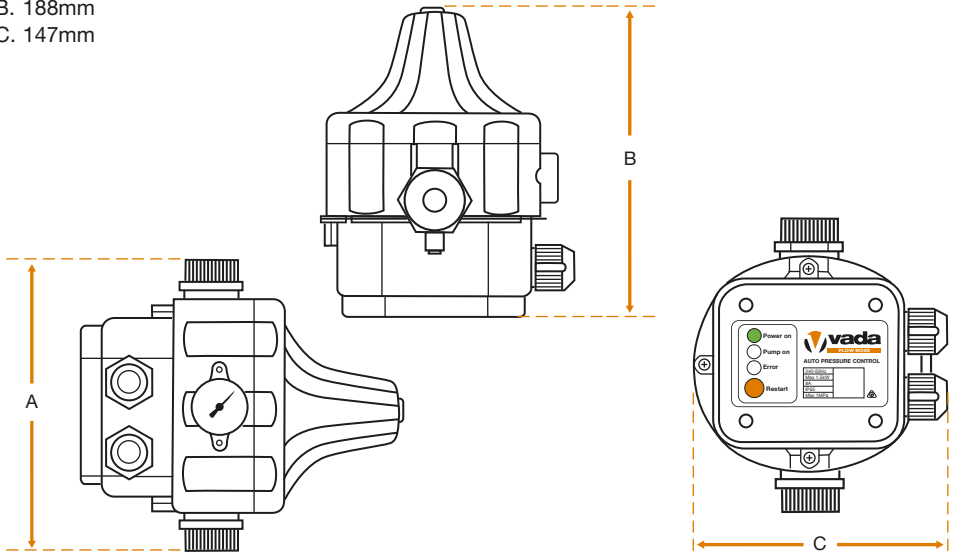

TECHNICAL INFORMATION

SPECIFICATIONS

Inlet	25mm MI
Outlet	25mm MI
Max operating pressure	1000kPa / 10 bar
Min pump pressure	250kPa / 2.5 bar
Min-max water temperature	1°C-65°C
Min-max ambient temperature	1°C-40°C
Supply voltage	1~240V 50Hz
Cut-in pressure	150-300kPa / 1.5-3 bar

Max power	1.5kW
Max current	10A
IP rating	IP65

PRODUCT DIMENSIONS

VFB-MSU25

- A. 210mm
- B. 148mm

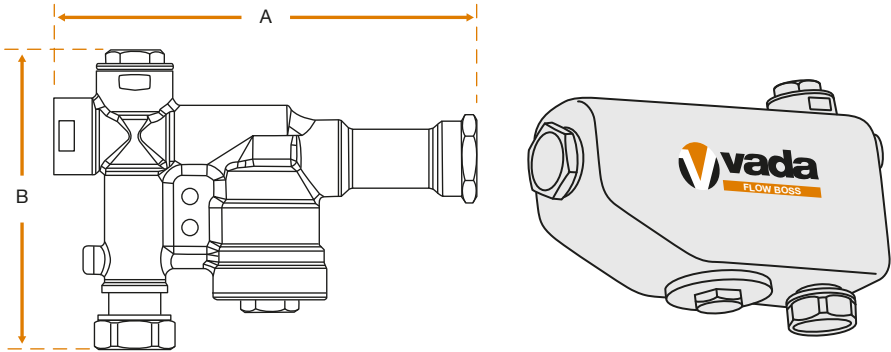

TECHNICAL INFORMATION

VFB-MSU25

SPECIFICATIONS

Pump inlet	25mm FI
Mains water in	25mm FI
Outlet	25mm FI
Max mains pressure	1000kPa / 10 bar
Min pump pressure	350kPa
Max flow rate	100lpm
Max water temp	50°C

*Ensure proper protection against freezing weather.

Certified to Watermark standard WMTS477.

Complies to AS/NZS 3500.1 when installed by a licensed plumber

Note: According to AS/NZS 3500.1 maximum allowable pressure in buildings is 500 KPa.

PRODUCT DIMENSIONS

- A. 52mm
- B. 181mm
- C. 80mm
- D. 106mm
- E. 75mm
- F. 235mm
- G. 119mm
- H. 120mm
- I. 115mm
- J. Ø48mm

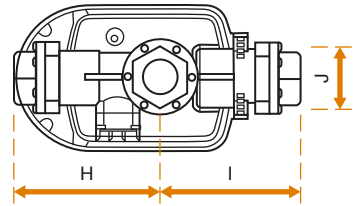
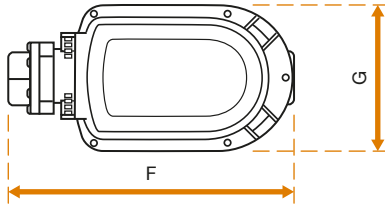
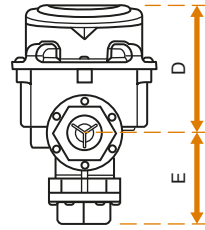
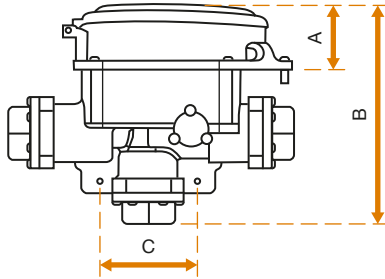

TECHNICAL INFORMATION



SPECIFICATIONS	
Supply voltage	1~230–240 50Hz
Max electrical load	10A / 2400W
Power standby	3.5W
Control power (on)	30W
IP rating	IP44
Min flow rate	1lpm
Min mains pressure	1 bar
Max operating pressure	10 bar
Min–max water temperature	1°C–40°C
Min–max ambient temperature	1°C–40°C

CONNECTION	
Mains water supply inlet	25mm FI BSP
Pump connection	25mm FI BSP
Water outlet connection	25mm FI BSP



TROUBLESHOOTING

Having trouble? Sort it out here, quick smart.



If these solutions do not solve the problem, please visit your local Reece Irrigation & Pools branch.

SYMPTOM	CAUSE	SOLUTION
The pump will not start (no water is being pumped and it is not making any noise).	There may be no power supply to the pump.	<ol style="list-style-type: none"> 1. Ensure that the power is turned on and check the connection to the power point. 2. Fuse may have blown. 3. Electrical power line may have been damaged.
	The pump motor protection may have tripped.	Ensure there is no mechanical resistance on the pump rotor: <ol style="list-style-type: none"> 1. Disconnect all electrical power. 2. Remove the fan cover. 3. Rotate the fan by hand and it should rotate freely.
		Check that the pump is not blocked by external objects that are causing the pump to seize. <ol style="list-style-type: none"> 1. Disassemble pipework and pump housing. 2. Clean impellers.
		 It is recommended to call a pump technician or licensed professional.
		Check that the power cables and relative connections are not damaged.
		Check if the pump winding is damaged and replace if necessary.  This should only be done by a qualified electrician.
	Check the VFB-APC for pump protection shutdowns.	
The static head on the discharge line is greater than the cut-in pressure.	Raise the cut-in pressure on the VFB-APC to suit the application.	



SYMPTOM	CAUSE	SOLUTION
	The pump capacitor may be damaged.	It is recommended to call a pump technician or licenced professional.
	The pump shaft may be locked or jammed.	Check for blockages that may be causing the pump to seize: 1. Turn the power off. 2. Rotate the fan and ensure it spins freely with no resistance. 3. Remove pump casing and check for objects jammed between moving components.  It is recommended to call a pump technician or licensed professional.
	The electronic card in the pressure controller may be broken. <i>*Only applicable if a pressure controller has been installed.</i>	If a pressure controller has been installed, the electronic card in the controller may need to be removed and replaced with a new card, or a new unit entirely.  This should only be done by a qualified electrician.
	Voltage failure.	 Check with a licensed electrical contractor to ensure voltage is correctly supplying the unit. Refer electrical data in manual.

TROUBLESHOOTING

SYMPTOM	CAUSE	SOLUTION
<p>The pump will not start, but is making noise.</p>	<p>The pump may be jammed.</p>	<p>If there is a humming sound coming from the pump motor, this may be due to debris or damage to the impellers being blocked and no longer turning or damage due to incorrect pump selection.</p> <ol style="list-style-type: none"> 1. Check pump internals for debris. 2. Check system pump requirement. <p> This should only be done by a qualified electrician.</p>
	<p>Failed capacitor.</p>	<p>Contact a licensed technician to replace the failed capacitor.</p>
	<p>The strainer is blocked.</p>	<p>Clean the filter by following the steps below:</p> <ol style="list-style-type: none"> 1. Close the isolating valve on the suction line. 2. Remove/clean in-line strainer or replace if necessary. 3. Once in-line strainer has been cleaned, open isolating valve on suction line and retry for pressure.
<p>The pump stops after running for a short period of time.</p>	<p>The motor thermal protection may have tripped.</p>	<p>This is reset automatically once the motor has cooled.</p>
	<p>The power supply does not conform with the data on the nameplate.</p>	<p>Check the voltage on the power supply cable leads. If it does not conform, contact your local Reece branch. A licensed electrician will need to establish the power supply and compare this to the pumps requirements.</p>
	<p>A solid object may be blocking the pump impellers.</p>	<p>Check for solid objects that may be blocking the impellers.</p> <ol style="list-style-type: none"> 1. Disassemble pipework and pump housing. 2. Clean impellers. <p> It is recommended to call a pump technician or licensed professional.</p>



SYMPTOM	CAUSE	SOLUTION
	There may be rotation resistance in the pump fan.	<ol style="list-style-type: none">1. Disconnect all electrical power.2. Remove the fan cover.3. Rotate the fan by hand and it should rotate freely.
	There may be cavitation in the pump (demand for water is higher than it can pump). <i>*Cavitation can be identified by the noise of the pump. You will hear a bubbling, crackling sounds like marbles rattling inside the pump casing.</i>	The length of the suction pipe may be too long, or the internal diameter may be too small: <ol style="list-style-type: none">1. Reduce either the suction height or distance.2. Increase the suction pipe internal diameter to same size as the pump inlet or larger.
	There may be excessive ambient temperature.	The ambient temperature should be below 40°C. Check ambient temperature next to the pump using a thermometer.
	The pump fan may be damaged, or there may be insufficient ventilation to provide cooling.	<ol style="list-style-type: none">1. Remove fan cover to check and ensure fan blades do not have cracks or damages.2. Check pump cover to make sure there is sufficient ventilation and the openings are not blocked.
	The pump motor thermal cut out protection setting, or fuses may not be suitable.	Check protection devices with respect to rated current of pump. The circuit breaker should be rated to 10A.
	The pump power cable may be damaged.	Replacement parts required. Contact a pump technician or call your local Reece branch.
	The pump motor may be damaged.	There may be resistance in the pump motor shaft <ol style="list-style-type: none">1. Disconnect all electrical power.2. Remove the fan cover.3. Rotate the fan by hand to see if it rotates freely.4. Ensure fan blades do not have cracks or damages.5. Remove pump casing and check for objects jammed between moving components.6. If still jammed, or damaged, replacement parts required. Contact a pump technician or call your local Reece branch.

TROUBLESHOOTING

SYMPTOM	CAUSE	SOLUTION
<p>The pump does not provide sufficient pressure.</p>	<p>Air may be trapped in the pipework.</p>	<p>The pump may have not been primed correctly and there is potential of air still in the suction pipeline.</p> <ol style="list-style-type: none"> 1. Check the pressure gauge on the side of the pressure control to determine if that model pump is operating correctly when referencing its pump curve. 2. Bleed air from system while the suction line is connected to the pump: <ol style="list-style-type: none"> a) Above ground tank: Remove priming plug on pump casing. Allow water to flow through via gravity until all air has been expelled. b) Below ground tank: Ensure foot valve is installed and not leaking through damage or debris. Fill up suction line and casing from priming point. 3. Activate all appliances/outlets sequentially from the nearest to the furthest outlet. Repeat if necessary. 4. If problem persists, please contact the Reece branch where the pump was purchased from. <p>Refer to page 16 for more information on priming the pump.</p>
	<p>The suction pipe internal diameter may be too small.</p>	<p>A suction pipe size that is too small will cause high pressure loss or cavitation. Increase the pipe size to an internal diameter that is the same size as the suction inlet, or larger.</p> <p>Note: This means for a 25mm inlet pump a 32mm PN12.5 Poly Pipe must be used.</p>
	<p>Debris may be caught in the pump impeller.</p>	<p>Check for solid objects that may be blocking the impellers.</p> <ol style="list-style-type: none"> 1. Disassemble pipework and pump housing. 2. Clean impellers. <p> It is recommended to call a pump technician or licensed professional.</p>



SYMPTOM	CAUSE	SOLUTION
	<p>The in-line strainer on the suction line may be blocked.</p>	<p>Check for blockages in the in-line strainer:</p> <ol style="list-style-type: none"> 1. Close the isolating valve on the suction line. 2. Remove/clean in-line strainer or replace if necessary. 3. Once in-line strainer has been cleaned, open isolating valve on suction line and retry for pressure.
	<p>There may be presence of leaks which are higher than the minimum flow of 0.6 l/min.</p>	<p>If the pump is turning on, then off in short durations there may be a leak in the pipework.</p> <ol style="list-style-type: none"> 1. Close the isolating valve on the discharge line of the pressure controller to see if the issue continues. 2. If it does not, check all taps, pipes, irrigation solenoid valves & toilet cisterns for leaks. 3. If it does continue, then check pressure control and suction pipe for debris. 4. If found, repair or replace pipework.
	<p>The pump may have been incorrectly sized for the application.</p>	<p>Contact the Reece store where the product was purchased from.</p>
	<p>The mesh filter in the digital water switching unit may be blocked. <i>*Only applicable if application is using a digital water switch.</i></p>	<p>If a digital water switching unit is installed:</p> <ol style="list-style-type: none"> 1. Switch off power to the unit. 2. Isolate the water lines and remove the pump barrel union. 3. Inspect/clean/replace the switching unit mesh filter.
<p>Pump performance is unstable (e.g. there is a change or reduction of pressure or flow output).</p>	<p>There may be cavitation in the pump (demand for water is higher than it can pump). <i>*Cavitation can be identified by the noise of the pump. You will hear a bubbling, crackling sounds like marbles rattling inside the pump casing.</i></p>	<p>The length of the suction pipe may be too long, or the internal diameter may be too small:</p> <ol style="list-style-type: none"> 1. Reduce either the suction height or distance. 2. Increase the suction pipe internal diameter to same size as the pump inlet or larger.



TROUBLESHOOTING

SYMPTOM	CAUSE	SOLUTION
Pump performance is unstable (e.g. there is a change or reduction of pressure or flow output) (continued).	Debris may be caught in the suction pipe.	Check for debris or blockages in the suction pipe: <ol style="list-style-type: none"> 1. Close the isolating valve on the suction line. 2. Check for debris. 3. If found, repair or replace pipework.
	There may be a leak in the suction pipe.	If the pump is turning on, then off in short durations there may be a leak in the suction pipe. <ol style="list-style-type: none"> 1. Close the isolating valve on the discharge line side of the pressure controller to see if the issue continues. 2. If it does, check the pressure control for debris or suction pipe for leaks. 3. If it does continue, then check pressure control and suction pipe for debris. 4. If found, repair or replace suction line.
Pump will not stop.	The electronic card in the pressure controller may be broken. <i>*Only applicable if application is using a pressure controller.</i>	If a pressure controller has been installed, the electronic card in the controller may need to be removed and replaced with a new card, or a new unit entirely.  This should only be done by a qualified electrician.
	The reset button on the pressure controller may be locked. <i>*Only applicable if application is using a pressure controller.</i>	If a pressure controller has been installed: <ol style="list-style-type: none"> 1. Press the reset button on the face of the unit several times. 2. Or, reset the power.
	The check valve on the suction line may be stuck in the open position.	The check valve may be blocked by debris. <ol style="list-style-type: none"> 1. Shut the relevant isolation valves. 2. Disconnect suction line. 3. Inspect check valve. 4. Clean or remove debris. 5. Ensure that an in-line strainer/filter is fitted in the suction line between the pump and the tank. <i>*Without an in-line strainer/filter the warranty may be void.</i>
	Flow detection valve on the Auto Press Control may be jammed in the open position.	<ol style="list-style-type: none"> 1. Remove the VFB-APC. 2. Inspect internals. 3. Clean or free debris. 4. Ensure that an in-line strainer/filter is fitted in the suction line between the pump and the tank.



SYMPTOM	CAUSE	SOLUTION
	<p>A pressure controller or mains switch over device has not been installed on the pump.</p>	<p>Without a pressure controller or mains water switch-over device, the pump will continue to operate until the power is switched off.</p>
	<p>The pump may not have been primed correctly and air may be trapped in the pipework.</p>	<p>The pump may have not been primed correctly and there is potential of air still in the suction pipeline.</p> <ol style="list-style-type: none"> 1. Check the pressure gauge on the side of the pressure control to determine if that model pump is operating correctly when referencing its pump curve. 2. Bleed air from system while the suction line is connected to the pump. <ol style="list-style-type: none"> a) Above ground tank: Remove priming plug on pump casing. Allow water to flow through via gravity until all air has been expelled. b) Below ground tank: Ensure foot valve is installed, fill up suction line and casing from discharge point. 3. Activate all appliances/outlets sequentially from the nearest to the furthest outlet. Repeat if necessary. 4. If problem persists, please contact the Reece branch where the pump was purchased from. <p>Refer to page 16 for more information on priming the pump.</p>
<p>Pump is turning on then off in short durations.</p>	<p>The pump may not be providing sufficient pressure.</p>	<p>The pump may not have been primed correctly and there could be potential of air still in the suction pipeline. Check the pressure gauge on the side of the pressure controller to determine if that model pump is operating correctly when referencing its pump curve.</p> <p>The suction pipe diameter may be too small and causing high pressure loss or cavitation. Increase the pipe size to an internal diameter that is the same size as the suction inlet, or larger.</p> <p>Note: This means for a 25mm inlet pump a 32mm PN12.5 Poly Pipe must be used.</p>

TROUBLESHOOTING

SYMPTOM	CAUSE	SOLUTION
Pump is turning on then off in short durations (continued).	The pump may not be providing sufficient pressure (continued).	There may be debris caught within the first impeller not allowing pressure to be created: <ol style="list-style-type: none"> 1. Disassemble pipework and pump housing. 2. Clean impellers.  It is recommended to call a pump technician or licensed professional.
		The pump may not be suitable for the water application. Check to confirm pump suitability on page 10.
	There may be presence of leaks which are higher than the minimum flow of 0.6 l/min.	If the pump is turning on, then off in short durations there may be a leak in the pipework. <ol style="list-style-type: none"> 1. Close the isolating valve on the discharge line of the pressure controller to see if the issue continues. 2. If it does not, check all taps, pipes, irrigation solenoid valves & toilet cisterns for leaks. 3. If it does continue, then check pressure control and suction pipe for debris. 4. If found, repair or replace pipework.
	The electronic card in the pressure controller may be broken. <i>*Only applicable if application is using a pressure controller.</i>	If a pressure controller has been installed, the electronic card in the controller may need to be removed and replaced with a new card, or a new unit entirely.  This should only be done by a qualified electrician.
The pump vibrates and operates noisily.	The pump and pipework may not be firmly anchored.	Fix the pump and pipes securely.
	There may be cavitation in the pump (demand for water is higher than it can pump). <i>*Cavitation can be identified by the noise of the pump. You will hear a bubbling, crackling sounds like marbles rattling inside the pump casing.</i>	The length of the suction pipe may be too long, or the internal diameter may be too small: <ol style="list-style-type: none"> 1. Reduce either the suction height or distance. 2. Increase the suction pipe internal diameter to same size as the pump inlet or larger.
	The pump may have been incorrectly sized for the application.	Contact the Reece store where the product was purchased from.



SYMPTOM	CAUSE	SOLUTION
No water is delivered from the pump, or the pump performance has decreased.	The rainwater tank may be empty.	<ol style="list-style-type: none">1. Check the tank level.2. If empty/low, wait for the tank to refill.
	There may be no power supply to the pump.	<ol style="list-style-type: none">1. Ensure that the power is turned on and check the connection to the power point.2. Fuse may have blown. Contact a pump technician or contact your local Reece branch to replace fuse.3. Electrical power line may have been damaged.
	The suction or discharge line may be closed.	Check the isolation valve and ensure that it is open at the water source (tank outlet).
	There may be bad signal from the float switch. <i>*Applicable to VFB-DSU only.</i>	Check the installation and operation of the float switch. Refer to the full Vada Flow Boss Digital Water Switching Unit manual for instructions on how to install the float switch.
	The pump may not have been primed correctly.	<p>There is potential of air still in the suction pipeline.</p> <ol style="list-style-type: none">1. Check the pressure gauge on the side of the pressure control to determine if that model pump is operating correctly when referencing its pump curve.2. Bleed air from system while the suction line is connected to the pump.<ol style="list-style-type: none">a) Above ground tank: Remove priming plug on pump casing. Allow water to flow through via gravity until all air has been expelled.b) Below ground tank: Ensure foot valve is installed, fill up suction line and casing from discharge point.3. Activate all appliances/outlets sequentially from the nearest to the furthest outlet. Repeat if necessary.4. If problem persists, please contact the Reece branch where the pump was purchased from. <p>Refer to page 16 for more information on priming the pump.</p>

TROUBLESHOOTING

SYMPTOM	CAUSE	SOLUTION
<p>No water is delivered from the pump, or the pump performance has decreased (continued).</p>	<p>The in-line strainer on the suction line may be blocked.</p>	<p>If you do not regularly clean the filter, it will clog up and cause the pump to fail.</p> <ol style="list-style-type: none"> 1. Close the isolating valve on the suction line. 2. Remove/clean in-line strainer or replace if necessary. 3. Once in-line strainer has been cleaned, open isolating valve on suction line and retry for pressure.
	<p>The mesh filter in the digital water switching unit may be blocked. <i>*Only applicable if application is using a digital water switch.</i></p>	<p>If a digital water switching unit is installed:</p> <ol style="list-style-type: none"> 1. Switch off power to the unit. 2. Isolate the water lines and remove the pump barrel union. 3. Inspect/clean/replace the switching unit mesh filter.
	<p>The pump may be sucking air.</p>	<p>There may be a leak in the suction line, or the pump was not primed correctly.</p> <ol style="list-style-type: none"> 1. Ensure that the joints on suction line are airtight. 2. If joints are airtight, reprime the pump by bleeding air from system while the suction line is connected to the pump. <ol style="list-style-type: none"> a) Above ground tank: Remove priming plug on pump casing. Allow water to flow through via gravity until all air has been expelled. b) Below ground tank: Ensure foot valve is installed, fill up suction line and casing from discharge point. 3. Activate all appliances/outlets sequentially from the nearest to the furthest outlet. Repeat if necessary. 4. If problem persists, please contact the Reece branch where the pump was purchased from. <p>Refer to page 16 for more information on priming the pump.</p>
<p>The liquid column may be above the check valve on the discharge line.</p>	<p>The weight of water can force the check valve on the discharge line to close. This prevents air being expelled from casing and suction line, affecting the pump's self-priming performance. Ensure water is completely drained above the level of the check valve.</p>	



SYMPTOM	CAUSE	SOLUTION
No water supply at all.	The rainwater tank may be empty.	<ol style="list-style-type: none"> 1. Check the tank level. 2. If empty/low, wait for the tank to refill.
	There may be blockage in the pipework.	<ol style="list-style-type: none"> 1. Close the isolating valves on the suction and discharge lines. 2. If switching from tank and mains water, close the isolating valve on the mains line also. 3. Check pipework and devices for debris 4. If found, clean or replace pipework. 5. Open isolating valves again to check and ensure flow rate is sufficient.
	The mains water valve may be closed. <i>*Only applicable if application is using a water switching unit.</i>	Check that the mains water isolation valve is open.
	Incoming mains water pressure may be greater than 1000kPa. <i>*Only applicable if application is using a digital water switch.</i>	Fit a pressure reduction valve to reduce incoming mains pressure.
The Green LED light on the pressure controller is not on. <i>*Only applicable if application is using a pressure controller.</i>	Power to the pressure controller may not have been turned on.	Check the power supply.
	The pressure controller may not have restarted.	The pressure controller is still in 'lock out' mode, meaning it has detected a loss of prime (tank empty). If the tank has been refilled with rainwater, the pressure control can be manually reset by pressing the "Restart" button on the device.

TROUBLESHOOTING

SYMPTOM	CAUSE	SOLUTION
<p>Pump “Error” or RED LED signal appears on the Pressure Controller. <i>*Only applicable if application is using a pressure controller.</i></p>	<p>The pump may have failed to prime.</p>	<p>Check there is water in the tank.</p> <p>The pressure controller is protecting the pump against loss of prime.</p> <ol style="list-style-type: none"> 1. Simply press the “Restart” button. 2. If the system fails again, the unit is detecting that there is air in the suction pipe and has shut down to protect the pump from long term damage. 3. Check the pressure gauge on the side of the pressure control to determine if that model pump is operating correctly when referencing its pump curve. 4. Bleed air from system while the suction line is connected to the pump. <ol style="list-style-type: none"> a) Above ground tank: Remove priming plug on pump casing. Allow water to flow through via gravity until all air has been expelled. b) Below ground tank: Ensure foot valve is installed, fill up suction line and casing from discharge point. 5. Activate all appliances/outlets sequentially from the nearest to the furthest outlet. Repeat if necessary. 6. If problem persists, please contact the Reece branch where the pump was purchased from. <p>Refer to page 16 for more information on priming the pump.</p>
		<p>The suction pipe diameter may be too small and causing high pressure loss or cavitation. Increase the pipe size to an internal diameter that is the same size as the suction inlet, or larger.</p> <p>Note: This means for a 25mm inlet pump a 32mm PN12.5 Poly Pipe must be used.</p>
		<p>There may be debris caught within the first impeller not allowing pressure to be created:</p> <ol style="list-style-type: none"> 1. Disassemble pipework and pump housing. 2. Clean impellers. <p> It is recommended to call a pump technician or licensed professional.</p>



SYMPTOM	CAUSE	SOLUTION
<p>The Digital Water Switching Unit has gone into “loss of prime” (no water is being delivered to pump).</p> <p><i>*Only applicable if application is using a digital water switch.</i></p>	<p>The pump has failed to prime, no water is being detected.</p>	<p>The system may have a large pipe network to charge and the pump is running high flow with no pressure.</p> <ol style="list-style-type: none">1. Close the isolating valve on the discharge line to almost 90% closed.2. Restart to ensure the pump has head pressure and fills the line slowly.
	<p>The valve on or between tank and switching unit inlet may be closed.</p>	<p>You will need to reprime the pump and reset the water switch.</p> <ol style="list-style-type: none">1. Open the isolation valve on the suction line.2. Bleed air from system while the suction line is connected to the pump.<ol style="list-style-type: none">a) Above ground tank: Remove priming plug on pump casing. Allow water to flow through via gravity until all air has been expelled.b) Below ground tank: Ensure foot valve is installed, fill up suction line and casing from discharge point.3. Activate all appliances/outlets sequentially from the nearest to the furthest outlet. Repeat if necessary.4. Reset the switching unit. <p>Refer to page 16 for more information on priming the pump.</p>
	<p>The mesh filter in the water switching unit is blocked.</p>	<ol style="list-style-type: none">1. Switch off power to the unit.2. Isolate the water lines and remove the pump barrel union.3. Inspect/clean/replace the switching unit mesh filter.

TROUBLESHOOTING

SYMPTOM	CAUSE	SOLUTION
<p>The Digital Water Switching Unit has gone into “loss of prime” (no water is being delivered to pump) (continued). <i>*Only applicable if application is using a digital water switch.</i></p>	<p>Pump may not have been primed (continued).</p>	<p>The pump may have not been primed and there is potential of air still in the suction pipeline.</p> <ol style="list-style-type: none"> 1. Check the pressure gauge on the side of the pressure control to determine if that model pump is operating correctly when referencing its pump curve. 2. Bleed air from system while the suction line is connected to the pump. <ol style="list-style-type: none"> a) Above ground tank: Remove priming plug on pump casing. Allow water to flow through via gravity until all air has been expelled. b) Below ground tank: Ensure foot valve is installed, fill up suction line and casing from discharge point. 3. Activate all appliances/outlets sequentially from the nearest to the furthest outlet. Repeat if necessary. 4. If problem persists, please contact the Reece branch where the pump was purchased from. <p>Refer to page 16 for more information on priming the pump.</p>
<p>No water is delivered from mains. <i>*Only applicable if application is using a water switch device.</i></p>	<p>There may be no mains water available.</p>	<p>Check the isolation valve on the water meter.</p>
	<p>There may be debris caught in the mechanical switching valve. <i>*Only applicable if application is using a mechanical water switch.</i></p>	<p>If a mechanical switching valve is installed, open the bleed plug. Refer to page 16 to identify bleed plug.</p>



WARRANTY

You have purchased a quality product from Reece Australia. This product is covered by a 2 year product warranty, 1 year parts and labour. This warranty covers faults in the product construction, material, and assembly.

The first 12 months are covered by an onsite visit from service agent after assessed by Reece After Sales and deemed a possible product fault. Infield service may also be conducted digitally in circumstances where an agent cannot physically attend the site. Warranty is subject to an evaluation by the agent based on installation instructions set out in the product manual.

A service fee may be charged to the customer if an aftersales service call is attended, and the fault is deemed to be a result of incorrect installation, or the points outlined below. Please note the site environment and associated product must be accessible and safe workplace for the service agent.

If a product is suspected of being faulty, please return to the Reece store it was purchased from and the product will be inspected by an authorised Reece representative. Products which are found upon inspection to be defective in construction, material, or assembly, will be repaired or exchanged with an equivalent product free of charge within the warranty period outlined above. Replaced items become Reece's property. Charges may apply if installation terms have not been met. All replacement products will be available for collection without charge to the customer at the nearest Reece branch to the customer's location, or elsewhere as agreed between the customer and Reece. Please note, warranty repairs may only be performed by our service representatives or an authorised customer service workshop, and any attempt to repair the device by the customer or unauthorised third parties shall terminate the warranty.

WARRANTY CONDITIONS

The warranty will apply only under all the following conditions:

- The pump has been installed by a qualified, licensed personnel.
- The pump is returned in good condition and has not arrived damaged.
- The pump is located so that it will NOT be prone to freezing.
- The pump is being used with clean water only and is NOT being used with alternative fluids specifically abrasive, corrosive, or explosive fluids.
- The pump is isolated from electrical supply during installation and any subsequent service work.
- The electrical installation is in accordance with the national wiring rules (AS/NZS 3000).
- The pump has NOT been lifted/moved/ carried by the electrical or float switch cables.
- The steps outlined in this manual and all accompanying quick start guides have been adhered to.
- The pump has been installed for and subjected to domestic residential use only subject to local building a municipality guideline.
- Failure is due to a fault in the manufacture of the project. In this case, proof of purchase, date of purchase and serial number is required.



This warranty does not include faults caused by:

- Failure to adhere to the conditions above.
- Normal wear and tear.
- Inadequate or complete lack of maintenance.
- Chemical, electrochemical, or electrical influences.
- Harsh detergents or abrasive cleaners used on product finishes.
- Unsuitable or improper use.
- Incorrect installation or installation not in accordance with the instructions provided.
- Inadequate protection of the pump.

EXCLUSIONS

To the fullest extent permitted by law, Reece excludes all liability for damage or injury to any person, damage to any property and any indirect consequential or other loss or damage. To the maximum extent permitted by law, Reece excludes all warranties other than those set out above.

