

# EVERHOT®

## HEAVY DUTY GAS



GAS

260L  
275L

CAPACITY

51 MJ/HR  
200 MJ/HR

INPUT

INDOOR  
OUTDOOR

INSTALLATION

5  
YEAR

CYLINDER  
WARRANTY<sup>20</sup>



Everhot Heavy Duty Gas is a robust commercial water heater range designed to provide between 380 and 970 litres of hot water in the first hour and 190 to 750L/hr recovery hour after hour at 50°C temperature rise.

## FEATURES

- Available in the most popular capacities of 260L / 51MJ/hr input and 275L / 200MJ/hr input
- Indoor and outdoor natural gas models available
- Direct replacement for the most popular heavy duty gas models
- Heavy duty enamel and multiple anodes<sup>21</sup> provide long service life
- Indoor 275 model has automatic flue damper reducing heat loss by up to 60% compared to AGA maximum allowance
- Hot surface ignition on 275L models
- 82°C capable for sanitising applications on 275L models
- Manifold multiple units together for greater capacity and output
- Mains pressure
- Made in Australia
- 5 year cylinder warranty<sup>20</sup>
- Full warranty support through a comprehensive national service network

Product data: page 15



Made by Rheem Manufacturing

# HEAVY DUTY GAS

SPECIFICATIONS		OUTDOOR MODELS		INDOOR MODELS		
Heavy Duty Gas		Everhot Model Number	632260	635275	622260	625275
		Reece Product Code	1306823	1306824	1306821	1306822
Storage Capacity	Litres	260	275	260	275	
Thermal Input (natural gas)	MJ/hr	51	200	51	200	
Recovery @ 50°C rise	L/hr	190	750	190	750	
First Hour Delivery	L	380	970	380	970	
Water Hot and Cold Connections	BSPF	Rp 1¼	Rp 1¼	Rp 1¼	Rp 1¼	
Gas Connection	BSPF	Rp ½	Rp ¾	Rp ½	Rp ¾	
T&PR Valve Connection	BSPF	Rp ¾	Rp ¾	Rp ¾	Rp ¾	
T&PR Valve Setting	kPa	1000	1000	1000	1000	
ECV	kPa	850	850	850	850	
<b>Max. Water Supply Pressure</b>						
without ECV fitted	kPa	800	800	800	800	
with ECV fitted	kPa	680	680	680	680	
Max. Thermostat Setting	°C	65	82	65	82	
Min. Thermostat Setting	°C	off	60	off	60	
Electrical Connection		-	2m 10A plug and lead	-	2m 10A plug and lead	
Electrical Rating 240V 50Hz		-	250 Watts / 1.1 Amps	-	150 Watts / 0.65 Amps	
Maintenance Rate	MJ/day	30.7	50.7	33.9	26.1	
<b>Dimensions</b>						
A	mm	1640	1885	1660	1910	
B	mm	590	645	590	645	
C	mm	680	780	670	780	
D	mm	1320	1454	1320	1454	
E	mm	330	704	330	704	
F	mm	295	341	297	341	
G	mm	1520	1706	1520	1706	
H	degrees	27	33	27	33	
K	mm	655	692	655	692	
M	mm	-	-	100	200	
P	mm	420	383	-	-	
Approx. Weight (inc. packaging)	kg	110	174	101	167	

Technical data is subject to change.

## Outdoor Models

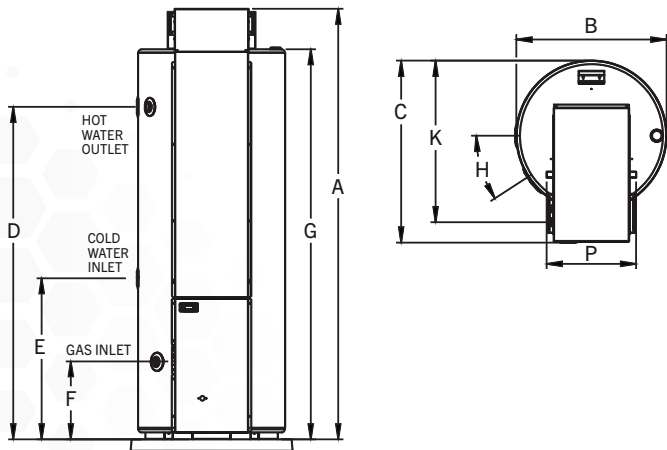

## Indoor Models

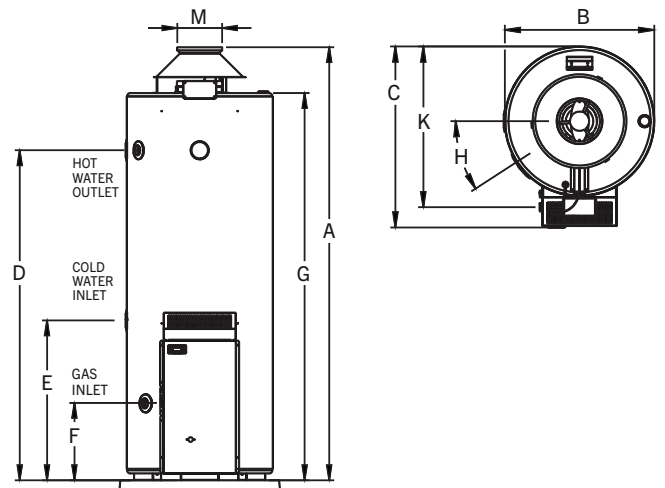

20. Warranty: 5 Year cylinder warranty, 1 Year parts and labour on all other components in commercial installations.

Conditions apply. See the Everhot warranty set out in the Owner's Guide and Installation Instructions or view online at [www.reece.com.au/Everhot](http://www.reece.com.au/Everhot).

21. Black anode suitable up to 600mg/L Total Dissolved Solids only available.

**EVERHOT**