



Memo Freya Double Bowl Sink No Taphole Granite Black

2411007

SPECIFICATIONS

Recommended Use	Domestic, Hotel & Commercial
Bowl Type	Double Bowl
Drainer Configuration	None
Mounting	Inset / Undermount
Overflow Configuration	No Overflow
Taphole Configuration	None
Sink Colour	Black
Finish	Stone
Material	Quartz Composite
Plug & Waste Size	90mm Basket Waste

WARRANTY

Warranty - Domestic Use	30 Years
Warranty - Commercial Use	12 Months
Spare Parts & Labour	12 Months

Please refer to Warranty Page for full Terms and Conditions



Sinks must be installed using a cutout template. No responsibility will be taken for damage that occurs where a template has not been used.

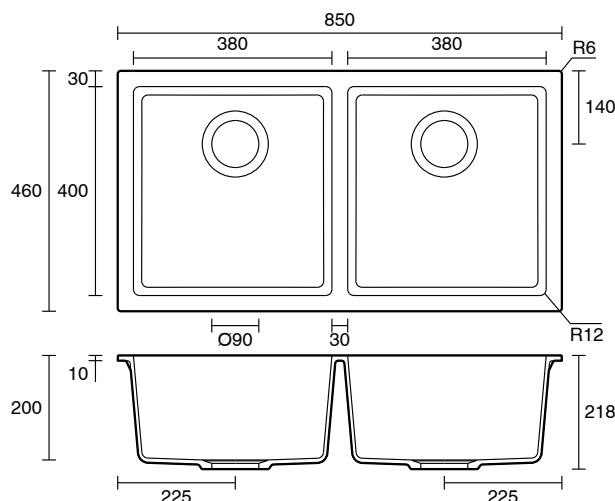

Dimensions are nominal measurements only.

CLEANING RECOMMENDATIONS:

We recommend the use of soapy water or approved cleaners. This product should not be cleaned with abrasive materials. Damage caused by any improper treatment is not covered by the product warranty. Refer to Warranty Conditions

Disclaimer: Products in this specification manual must by regulation be installed by licensed and registered trade people. The manufacturer/distributor reserves the right to vary specifications or delete models from their range without prior notification. Dimensions are nominal measurements only. Dimensions and set-outs listed are correct at time of publication however the manufacturer/distributor takes no responsibility for printing errors.

Published 30/08/2024

To see the complete Memo range go to www.reece.com.au

