

# BIS Strut Rail Beam Clamp

(H 36 05)

to make Strut rail fabrications

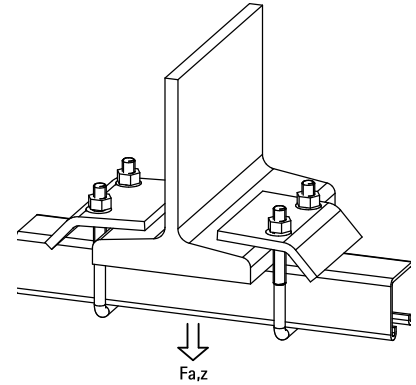

## Features and Benefits

- for a solid fixing to steel construction
- material: steel 1.0332
- without the need for welding or drilling
- hot dip galvanized
- always use 2 beam clamps per fixing

Part No.	A (mm)	G	L	B	H	b	s	Lm1	SW1	T <sub>inst</sub> (Nm)	For Rail	F <sub>a,z</sub> (N)	Pack 1
66581711	17.5	M10	69 mm	80	90		5.5	60	17	15	Strut 41x21 + 41x41 + 41x21D	5,700	25
66581721	20.0	M10	69 mm	80	130	44	6.0	75	17	15	Strut 41x62 + 41x82 + 41x41D + DS 5 (41 x 51)	5,700	25

*Also available in stainless steel 1.4401 (AISI 316).*

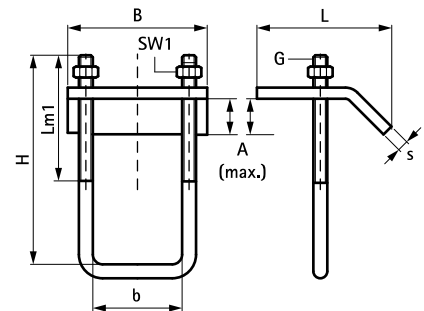

### Complementary

BIS RapidStrut® Fixing Rail (pg)  
 BIS RapidStrut® Fixing Rail (BUP1000)  
 BIS RapidStrut® Fixing Rail DS 5  
 (BUP1000)

### Complementary

BIS RapidStrut® Fixing Rail Double (pg)

### Alternative

BIS Strut 'Heavy Duty' Beam Clamp  
 BIS Strut 41x21D 'Heavy Duty' Set