



Modular 90° Wraparound Grab Rail | Left Hand

Model RBA4091-103



Materials & Features

Modular Stainless steel 90° wraparound WC grab rail meets the requirements of AS1428.1-2009 when installed correctly. The snap flange cover conceals the fixings.

Technical Detail

Rail 32mm [Dia], 304 Satin Stainless Steel
Fixings Included Screws and Plugs

Available Model

RBA4091-103 Modular 90° Wraparound Grab Rail, Left Hand

Related Products

RBA4091-113 Modular 90° Wraparound Grab Rail, Right Hand
RBA4090-300 90° LH + 300 Straight | Grab Rail Set
RBA4150-101 Accessible Compliant Backrest

Installation

Warning: Grab rails are no stronger than the anchors or walls to which they are attached and must be firmly secured in order to support the loads for which they are intended. Refer to local codes and Installation Instructions for location of fixing points, method of attachment, etc.

Important: Installation instructions and current rough-in details should be furnished with each fixture. Do not rough in without certified dimensions. Dimensions are subject to manufacturer's tolerance of +/-10mm.

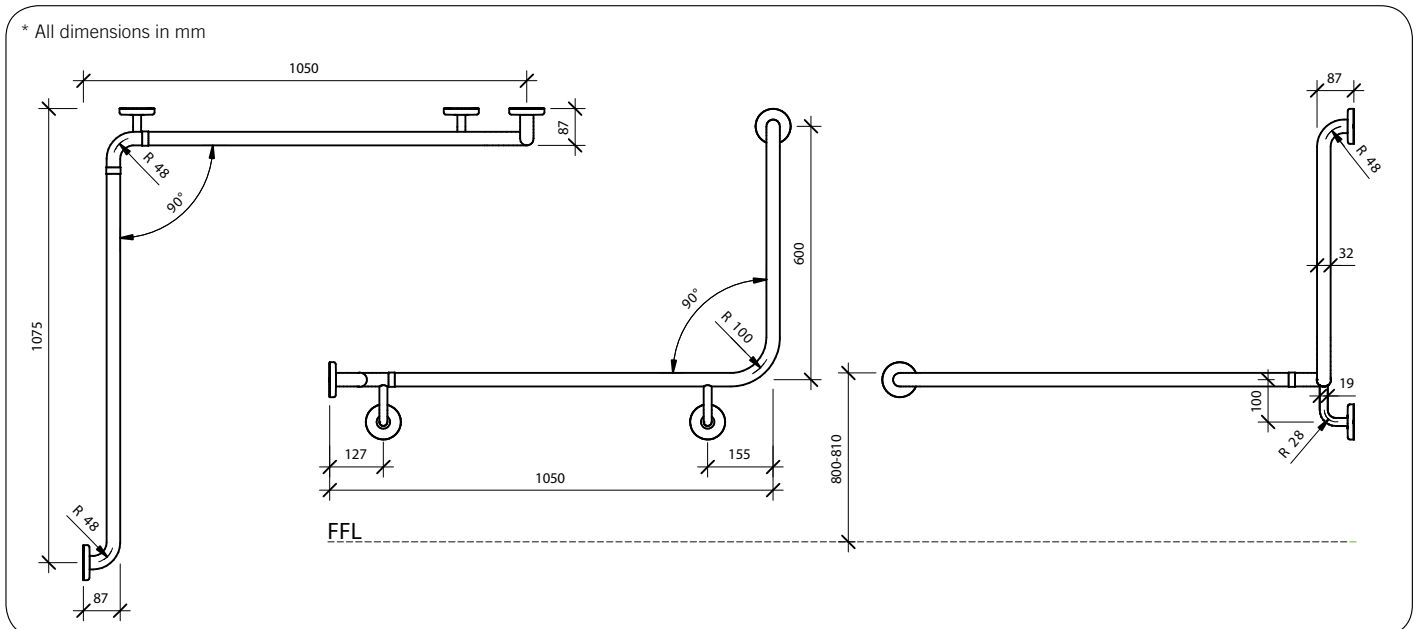

As improvements in the design and performance of RBA products are continuous, specifications may be subject to change without notice. The illustrations and descriptions herein are applicable to production as of the date of this Technical Data Sheet. Revised 08/19 © 2019 by RBA Group TD/Model RBA4091-103/1019