

Mizu Drift Dual Function Sensor Basin Mixer Chrome Battery Operated (6 Star)

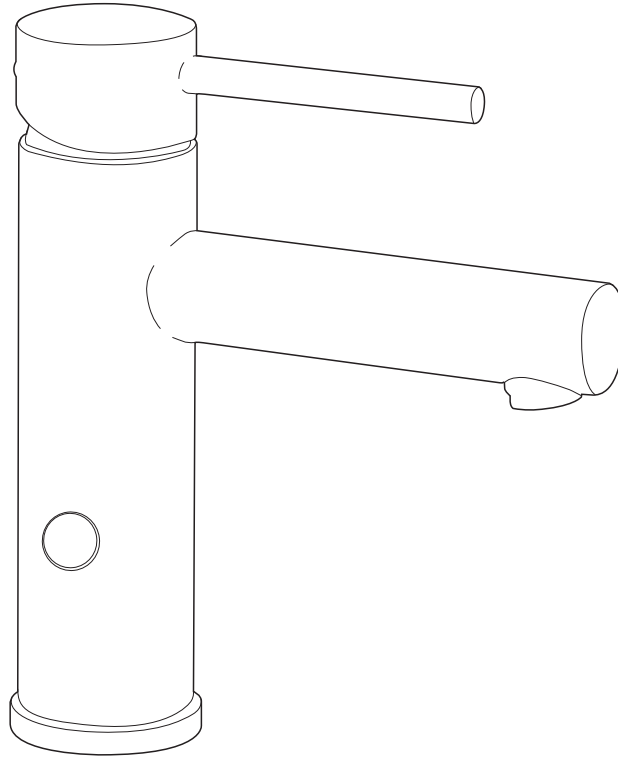

Components Supplied

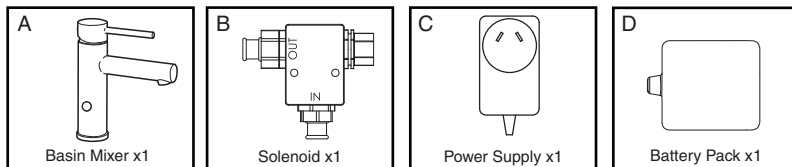

Tools Required

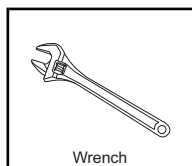

Installation Instructions



This product must be installed to the requirements of AS/NZS 3500 by a qualified plumber.

mizu

Installation

- Ensure installation area is free from dust and debris.
- Minimum hole size is 32mm diameter, with a maximum depth of 35mm.
- Make sure pipework is properly flushed and free of any obstructions which could affect operation.
- Direct hoses and cables through mounting hole.
- Securely mount tap to surface using rubber washer (ridges up), metal washer, and nut - tighten firmly using supplied fixing tool.
- With PTFE tape, connect solenoid to auto water line.
- Connect all incoming water lines to HOT and COLD stop taps, and to solenoid.

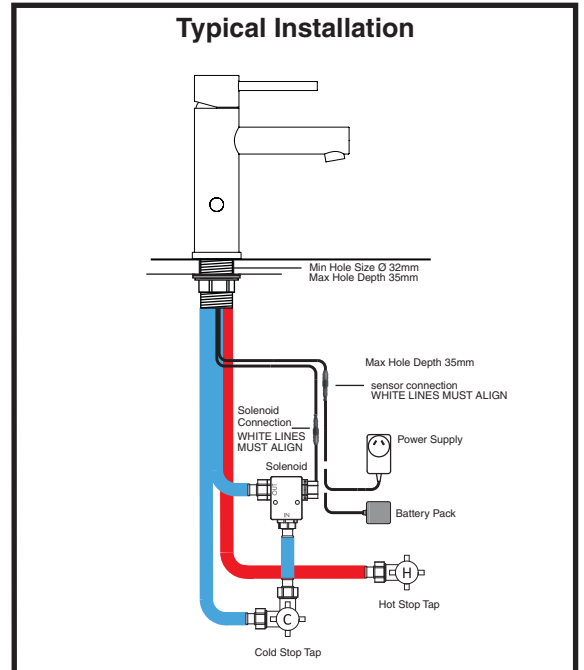

- Should warm water be required for auto water line, a tempering valve can be used to pre-mix hot and cold water prior to solenoid connection.
- Make electrical connections ensuring correct alignment of white lines - see image.
- Turn on HOT and COLD stop taps.
- Insert battery into holder or plug in power supply to standard power outlet, turn on.
- Open mixer handle and run some water through, close.
- Wave hand in front of sensor momentarily, water will run for 10 seconds and turn off. Again, wave hand in run for 10 seconds and turn off. Again, wave hand in turn off water. Tap is operational.

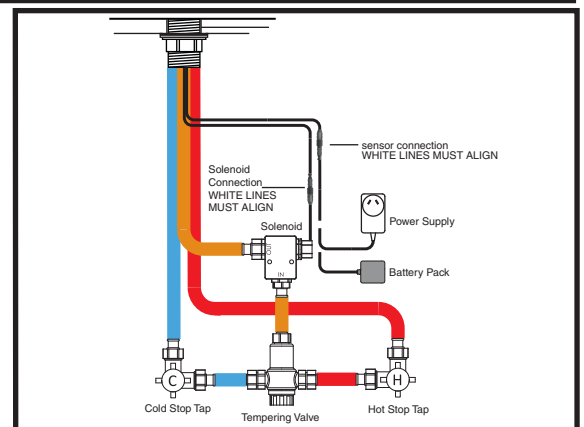

Technical Specifications

- TAP BODY - Solid brass - plated
- SENSOR OPERATION - wave on/wave off
- SENSOR RANGE - 60mm factory se
- OPERATING SUPPLY - 6v Lithium Battery
- 12v DC Power Supply
- OPERATING PRESSURE - 150 to 500kPa
- FLOW RATING - 4.0 liters per minute
- SOLENOID - Latching/soft closing
- MAX TEMPERATURE - 60°C

mizu

- The HOT/COLD mixer handle operates as normal. It does not control the temperature of the auto water line.
- The auto water line temperature is controlled through the installation. Either cold or warm water can be provided. Refer to Installation Instructions.
- To activate auto water line, place hand in front of sensor momentarily (within 60mm) - water will flow from outlet.

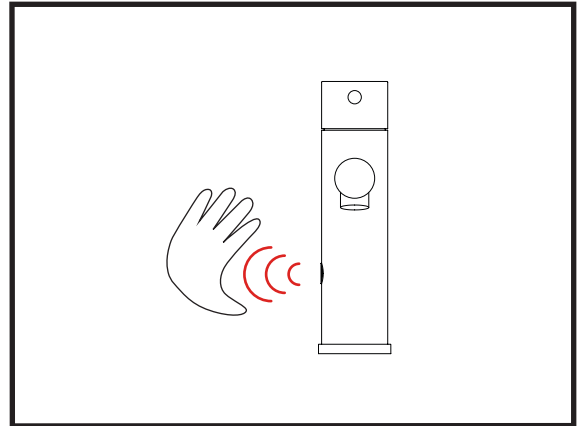

- Water flow can be stopped, within a 10 second period, by waving hand in front of sensor momentarily.
- If left for 10 seconds, water will cease automatically.

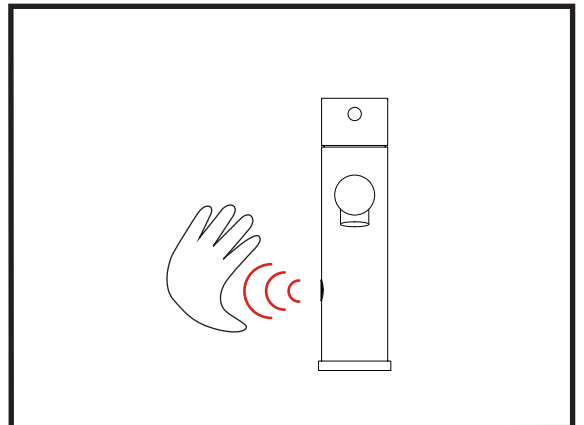

Care Details

We recommend the use of soapy water or approved cleaners. This product should not be cleaned with abrasive materials or solvents. Damage caused by any improper treatment is not covered by the product warranty. Refer to Warranty Conditions

Plumbers, please ensure a copy of the installation instruction is left with the end user for future reference.

