

PRODUCT CATALOGUE

COMMERCIAL ACCESSORIES

Available at Reece







Since its foundation in 1911, Franke's success has been based on innovative engineering, unique design, and outstanding Swiss quality. Franke Water Systems is the world's leading sanitary specialist offering a full solution for your public, semi-public and commercial washroom.

Innovative system solutions are the hallmark of Franke Water Systems. Future-oriented fittings and furnishing elements for washrooms and bathrooms are impressive in their quality, longevity, functionality and not least in their design.

SIMPLICITY

To keep the natural flow, we offer easy-care functionalities.



FUTURE THINKING

Our planet is important to us. That's why we develop sustainable ideas.



INVENTIVENESS

We are always looking for new and unusual solutions.



DESIGN

We place the highest demands on the design language of our products.



Our Franke commercial accessory range is designed to suit any public, semi-public and commercial washroom with a range of different options. Our products are made from the best 304 stainless steel with a consistent brushed satin finish. The products are anti-vandal with a standard Franke lock and key and offer a 5 year warranty.

COMMERCIAL OFFICE



EDUCATION



STADIUM & SPORT FACILITIES



HOTEL/RESTAURANTS



AGED CARE



CHILD CARE



HOSPITALS



CORRECTIONAL



INDUSTRY FACILITIES



MENTAL HEALTH



COUNCIL AMENITIES



TRANSPORT



COMMERCIAL DOUBLE TOILET ROLL HOLDER - FRK203057

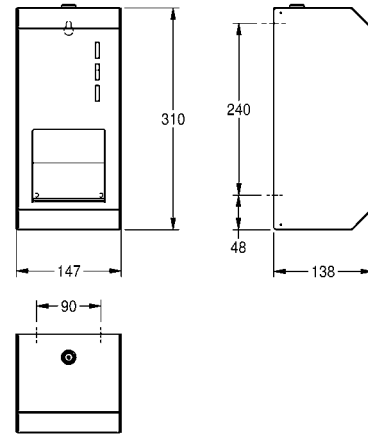

PRODUCT FEATURES - 2009321

- Both Rolls Enclosed To Prevent Water Splashing
- Roll Automatically Released After First Roll Finished
- Cylinder Lock With Franke Standard Key
- All Fixings Supplied
- 5 Year Warranty

PRODUCT INFORMATION

Overall Dimensions (mm)	147 (W) x 310 (H) x 138 (D)
Capacity	2 x 120mm Toilet Rolls
Material	304 Stainless Steel
Material Thickness	0.8mm
Surface Finish	Satin

COMMERCIAL JUMBO TOILET ROLL HOLDER - CHR669

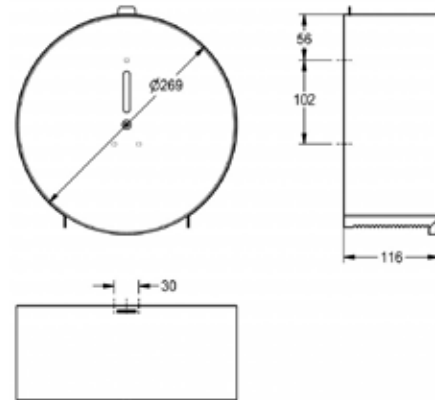

PRODUCT FEATURES - 2009322

- Left & Right Hand Tear-off Edges
- Closed Round Casting With Inspection Window
- Cylinder Lock With Franke Standard Key
- All Fixings Supplied
- 5 Year Warranty

PRODUCT INFORMATION

Overall Dimensions (mm)	269 (W) x 269 (H) x 118 (D)
Capacity	1 x 260mm Roll
Material	304 Stainless Steel
Material Thickness	0.8mm
Surface Finish	Satin

COMMERCIAL SOAP DISPENSER - FRK20205 1

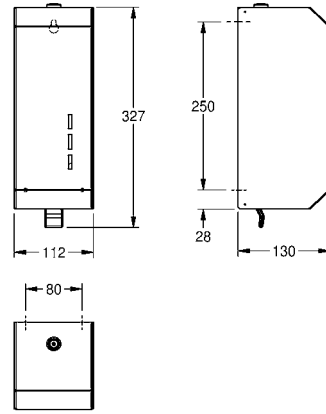

PRODUCT FEATURES - 2009323

- Removeable Soap Container
- Suitable For Liquids & Lotions
- Cylinder Lock With Franke Standard Key
- All Fixings Supplied
- 5 Year Warranty

PRODUCT INFORMATION

Overall Dimensions (mm)	112 (W) x 327 (H) x 130 (D)
Capacity	800mm
Material	304 Stainless Steel
Material Thickness	0.8mm
Surface Finish	Satin

COMMERCIAL PAPER TOWEL DISPENSER - FRK201069

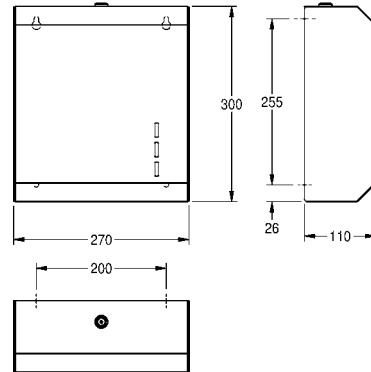

PRODUCT FEATURES - 2009320

- Multiple Fixing Points For Replacement Installation
- Folded Cover With No Exposed Hinges
- Cylinder Lock With Franke Standard Key
- All Fixings Supplied
- 5 Year Warranty

PRODUCT INFORMATION

Overall Dimensions (mm)	270 (W) x 300 (H) x 110 (D)
Capacity	400pc Folded Paper
Material	304 Stainless Steel
Material Thickness	0.8mm
Surface Finish	Satin

COMMERCIAL HIGH SPEED HAND DRYER - FRK2090 12

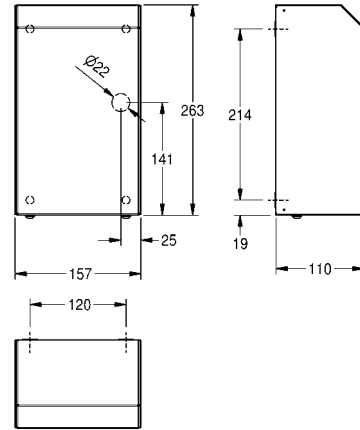

PRODUCT FEATURES - 2009324

- Fast 7 - 10 Second Drying Time
- Blue Infrared Light To Eliminate Bacteria
- Opto-Electronic Sensor for Touch-Free Operation
- All Fixings Supplied
- 5 Year Warranty

PRODUCT INFORMATION

Overall Dimensions (mm)	157 (W) x 263 (H) x 110 (D)
Air Volume	80m ³ / H
Material	304 Stainless Steel
Material Thickness	0.8mm
Surface Finish	Satin

COMMERCIAL COMFORT HAND DRYER - FRK2090 13

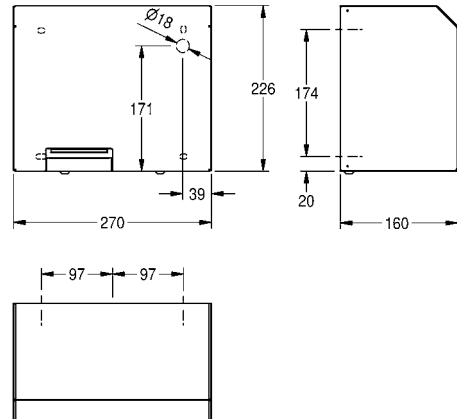

PRODUCT FEATURES - 2009331

- Fast 12 - 14 Second Drying Time
- Blue Infrared Light To Eliminate Bacteria
- Opto-Electronic Sensor for Touch-Free Operation
- All Fixings Supplied
- 5 Year Warranty

PRODUCT INFORMATION

Overall Dimensions (mm)	270 (W) x 226 (H) x 160 (D)
Air Volume	255m ³ / H
Material	304 Stainless Steel
Material Thickness	0.8mm
Surface Finish	Satin

COMMERCIAL SURFACE COMBINATION UNIT 19ltr - FRK601072

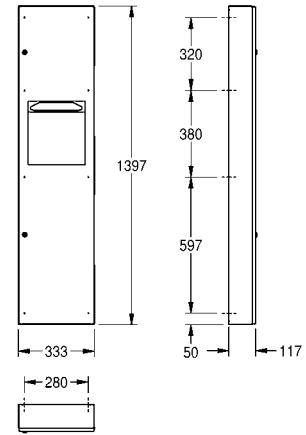

PRODUCT FEATURES - 2009326

- Sleek Design With No Exposed Bin
- Removable Stainless Steel Waste Bin
- Double Cylinder Lock With Franke Standard Key
- All Fixings Supplied
- 5 Year Warranty

PRODUCT INFORMATION

Overall Dimensions (mm)	333 (W) x 1397 (H) x 117 (D)
Capacity	1000pc Paper
Material	304 Stainless Steel
Material Thickness	1.2mm
Surface Finish	Satin

COMMERCIAL RECESSED COMBINATION UNIT 19ltr - FRK601072E

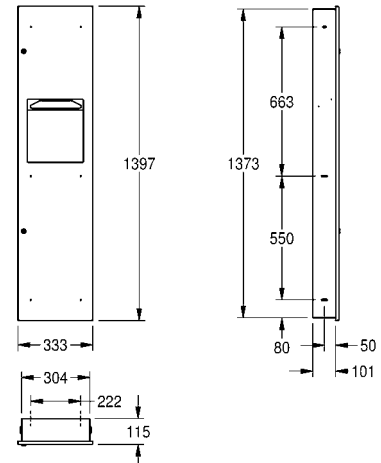

PRODUCT FEATURES - 2009325

- Sleek Design With No Exposed Bin
- Removable Stainless Steel Waste Bin
- Double Cylinder Lock With Franke Standard Key
- All Fixings Supplied
- 5 Year Warranty

PRODUCT INFORMATION

Overall Dimensions (mm)	333 (W) x 1397 (H) x 101 (D)
Capacity	1000pc Paper
Material	304 Stainless Steel
Material Thickness	1.2mm
Surface Finish	Satin

COMMERCIAL SURFACE COMBINATION UNIT 6.5ltr - FRK601071

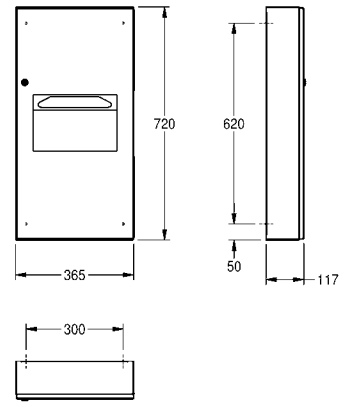

PRODUCT FEATURES - 2009328

- Sleek Design With No Exposed Bin
- Removable Stainless Steel Waste Bin
- Cylinder Lock With Franke Standard Key
- All Fixings Supplied
- 5 Year Warranty

PRODUCT INFORMATION

Overall Dimensions (mm)	365 (W) x 720 (H) x 117 (D)
Capacity	500pc Paper
Material	304 Stainless Steel
Material Thickness	1.2mm
Surface Finish	Satin

COMMERCIAL RECESSED COMBINATION UNIT 6.5ltr - FRK601071E

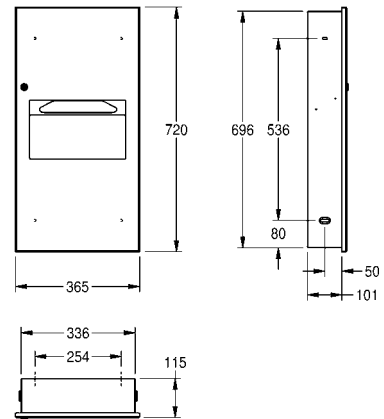

PRODUCT FEATURES - 2009327

- Sleek Design With No Exposed Bin
- Removable Stainless Steel Waste Bin
- Cylinder Lock With Franke Standard Key
- All Fixings Supplied
- 5 Year Warranty

PRODUCT INFORMATION

Overall Dimensions (mm)	365 (W) x 720 (H) x 101 (D)
Capacity	500pc Paper
Material	304 Stainless Steel
Material Thickness	1.2mm
Surface Finish	Satin

COMMERCIAL SURFACE WASTE BIN - FRK204 104

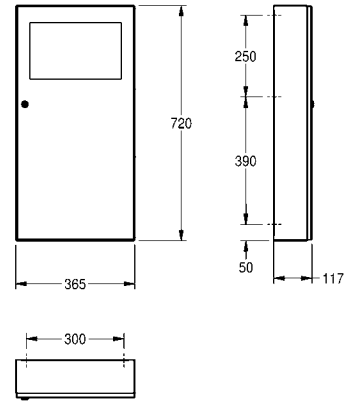

PRODUCT FEATURES - 2009330

- Sleek Design With No Exposed Bin
- Removable Stainless Steel Waste Bin
- Cylinder Lock With Franke Standard Key
- All Fixings Supplied
- 5 Year Warranty

PRODUCT INFORMATION

Overall Dimensions (mm)	365 (W) x 720 (H) x 117 (D)
Capacity	13.5ltr
Material	304 Stainless Steel
Material Thickness	1.2mm
Surface Finish	Satin

COMMERCIAL RECESSED WASTE BIN - FRK204 104E

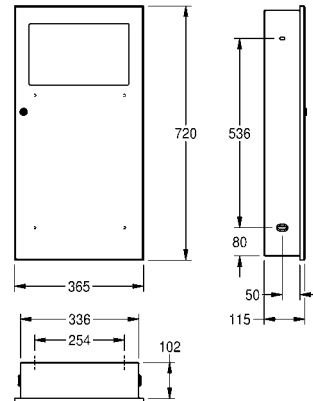

PRODUCT FEATURES - 2009329

- Sleek Design With No Exposed Bin
- Removable Stainless Steel Waste Bin
- Cylinder Lock With Franke Standard Key
- All Fixings Supplied
- 5 Year Warranty

PRODUCT INFORMATION

Overall Dimensions (mm)	365 (W) x 720 (H) x 115 (D)
Capacity	13.5ltr
Material	304 Stainless Steel
Material Thickness	1.2mm
Surface Finish	Satin

COMMERICAL SENSOR SOAP DISPENSER - FRK202067N

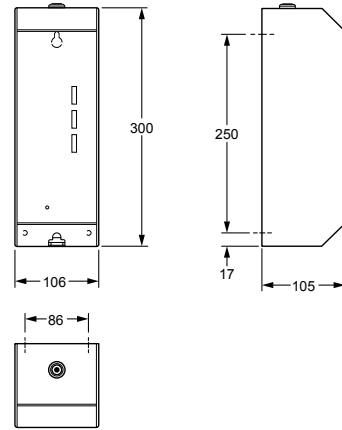

PRODUCT FEATURES - 226 1049

- Infrared Sensor Activity For Non-touch Operation
- Removable Soap Container
- LED-Display Shows Battery Status
- Cylinder Lock With Franke Standard Key
- Suitable For Liquids & Lotions

PRODUCT INFORMATION

Overall Dimensions (mm)	300 (W) x 106 (H) x 105 (D)
Capacity	800ml
Material	304 Stainless Steel
Material Thickness	0.8mm
Surface Finish	Satin

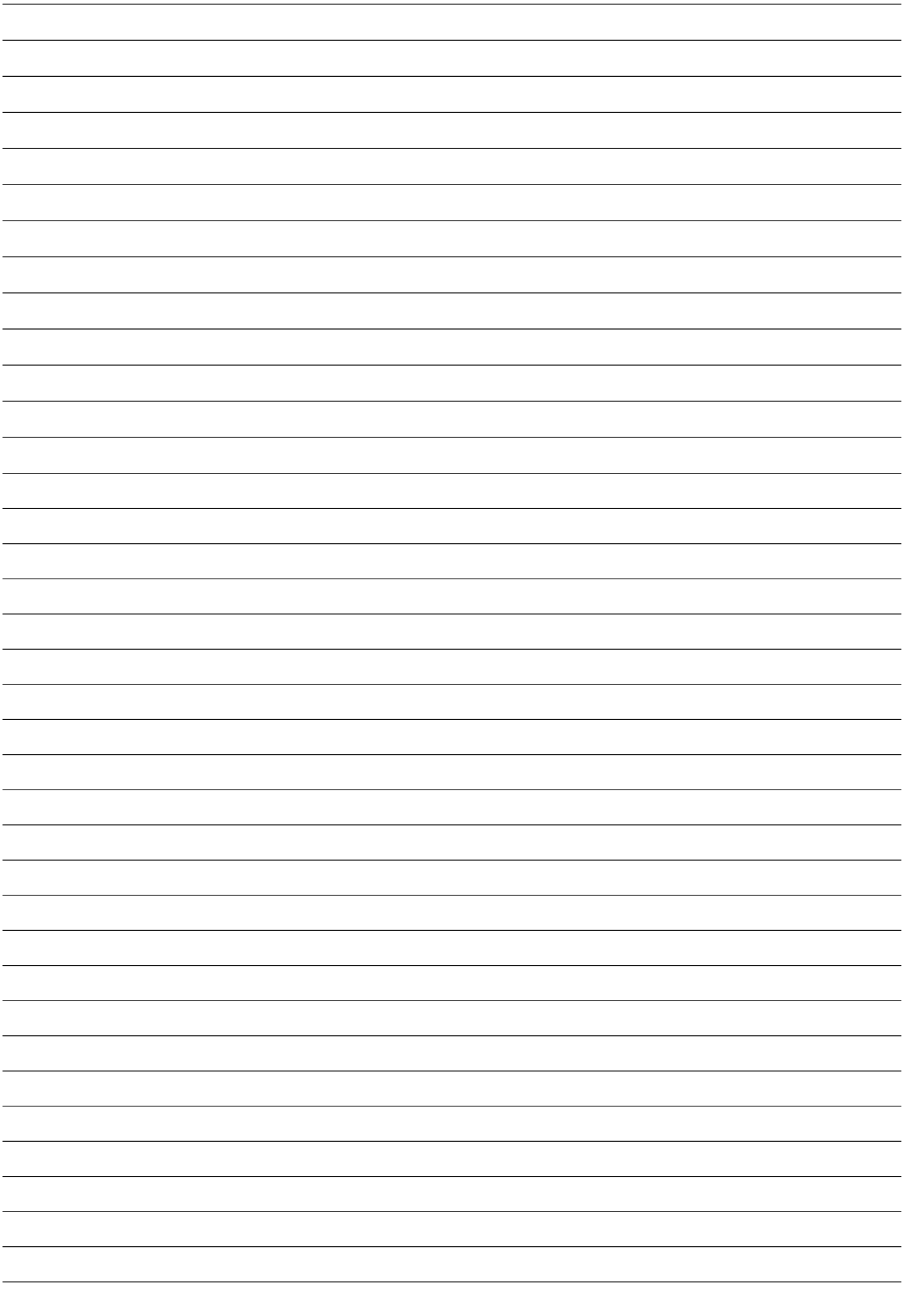





 www.franke.com

 @FrankeAUS

 @frankeaus

As our policy is one of continual improvement, the manufacturer's reserve the right to alter specifications without notice.

For our nearest bathroom showroom.
AUS : Call 1800 032 566 or visit reece.com.au
NZ: Visit www.reece.co.nz

Due to limitations in the printing process the colours in this brochure are a guide only.
The manufacturer/distributor reserves the right to vary specifications or delete models from their range without prior notification. The manufacturer / distributor takes no responsibility for printing errors.

Franke washroom products enjoy an extensive product warranty. Check product for details, terms and conditions apply. See www.reece.com.au/warranties for more information.

(BROCHURE CODE 2104905 V1)

PR Kitchen & Washroom Systems
83 Bangholme Road Dandenong
South
VIC 3175
Australia

Phone +61 3 9700 9100
Fax +61 3 9700 9191
info@prks.com.au
www.franke.com.au



MAKE IT WONDERFUL

