

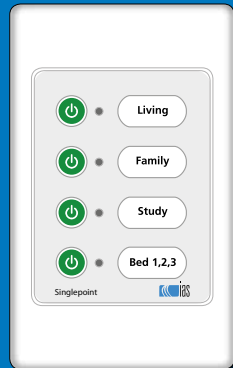

# Singlepoint 234 Wall Switch Kit



MYzone

Installation Manual

## **System Overview**

The Singlepoint 234 Wall Switch operates independently of the air conditioning plant to provide On/Off zoning control for two to four zones per wall switch module.

The kit is comprised of the following items:

- Singlepoint 234 zone wall switch (SNP234)  
- includes zone labels and one each of the 2, 3, and 4 button overlays
- 24 VAC Transformer

Motorised dampers are not included as part of this kit.

## **Electrical Requirements**

Power input to Controller .....24 volt AC  $\pm$  10%  
Line frequency .....50 Hz

## **Environmental Requirements**

Operating temperature .....0°C to 50°C  
Altitude.....0 to 2000 meters  
Operating Relative Humidity..... 10% to 80%  
Avoid static electricity hazards  
Avoid electromagnetic radiation sources  
Avoid dust contamination  
Avoid highly corrosive environments

## **Cabling Requirements**

Motor cables can be 6 core flat cable with 6p6c plugs, or 4 core flat cable with 6p4c plugs.

## **Technical Notes**

In the event of power loss and restore to the controller (i.e. blackout), all zones resume operation in the same state.

## **Singlepoint 234 Wall Switch**

All zone motors connect to and receive power from the wall panel. All motor connections are made using the plug in cable system for easy installation, terminal connections are provided for the 24V power supply.

## **Motorised Dampers**

Motorised dampers connect to the wall panel via the zone output sockets on the back.

## Component Positioning

The wall switch should be mounted in a central location within the air conditioned space. They are designed to be flush mounted to a cavity wall, but may be surface mounted through the use of a mounting block not less than 15mm deep.

The motorised dampers can be mounted at the takeoff point of the rigid duct or mounted in-line in the flexible duct.

## Commissioning

Set the number of zones required by positioning the jumper on the rear of the wall switch across the appropriate pins.

For 4 zone systems with no spill required discard the jumper.

For 4 zone systems with spill position the jumper across the “Zone4” pins. Zone 1 becomes the spill zone.

For 3 zone systems, position the jumper across the “Zone3” pins. Zone 1 becomes the spill zone.

For 2 zone systems, position the jumper across the “Zone2” pins. Zone 1 becomes the spill zone.

Zone 1 is always the output matching the top most button on the overlay corresponding to the number of zones selected.

Apply power to the system and switch each zone on and off to ensure each damper is functioning correctly.

## Wall Switch Operating Instructions:

To operate a zone, simply press the  button to turn the respective zone on or off.

The green LED beside the  button is illuminated to indicate the zone is on.

Full airflow should be available from ten seconds to two minutes after switching the zone on, depending on the stroke time of damper motor being used.

In the event of a power loss and restore to the controller (ie. blackout), the controller will return all zones to the position last set by the user.

### 4 Zone Connection Diagram

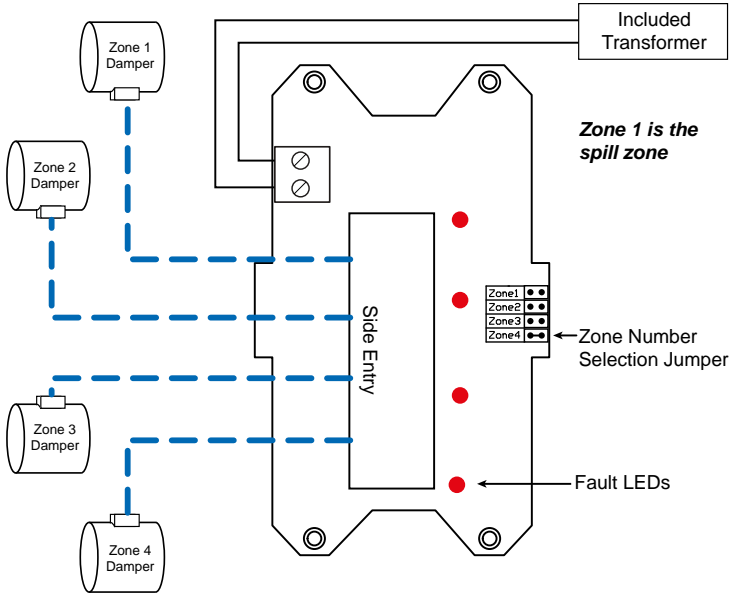

### 3 Zone Connection Diagram

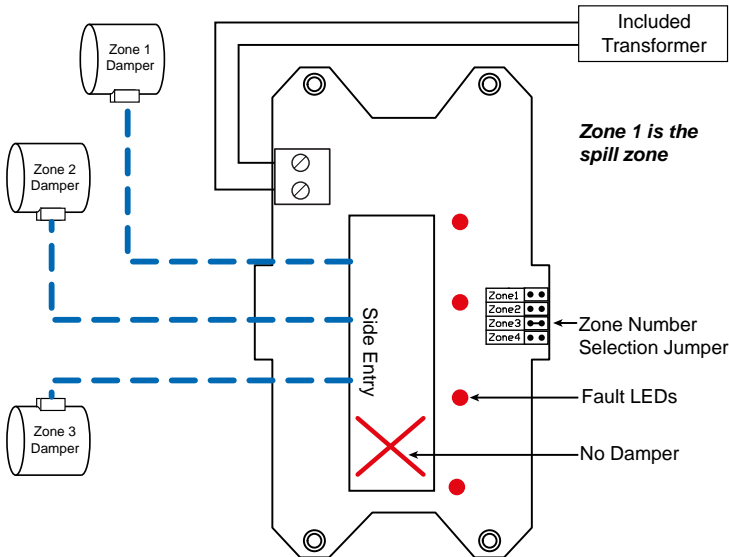

## 2 Zone Connection Diagram

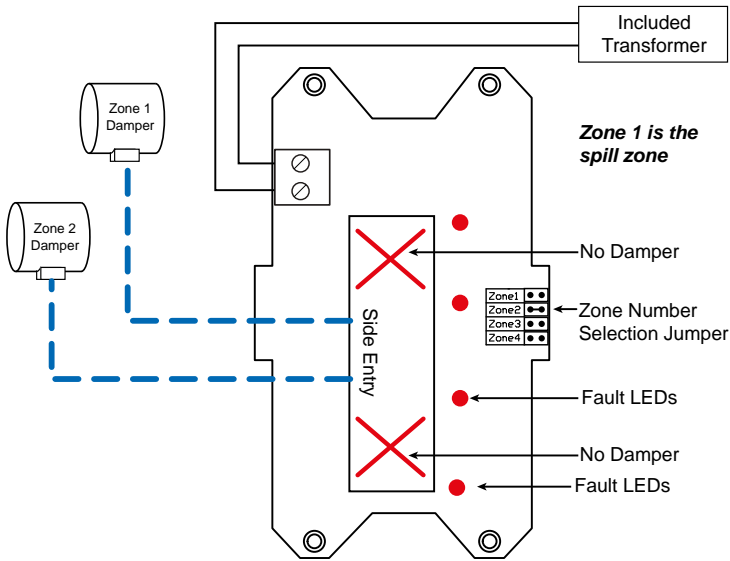

## Crimping Instructions



### **Never insert uncrimped plugs into the sockets.**

This may cause damage to the socket contacts. Crimped plugs should insert easily into sockets until the locking tab clicks into place. Plugs that have been incorrectly crimped may be difficult to insert, and may cause damage to the socket contacts if forced into place.



### **Cable connections are polarity conscious.**

It is essential that every cable termination for each installation is performed with the coloured inner conductors in the same order and position in the plug. Any two cable ends should appear identical if held side by side (provided they are of the same cable type - i.e. shielded or unshielded).

### Step 1

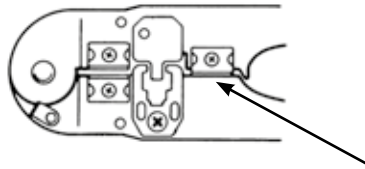

- Cut the cable to the desired length. Take care to ensure the ends are cut square.

### Step 2

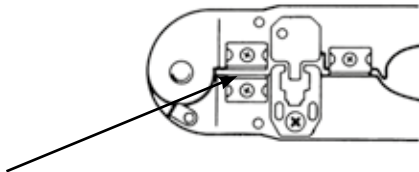

- Insert the cable between the stripper blades of the crimping tool so that it touches the metal stop.
- Squeeze the handles and pull the tool to remove the cables outer sheath and expose the insulated inner conductors.
- Ensure the insulation on the inner conductors is not damaged.

### Step 3

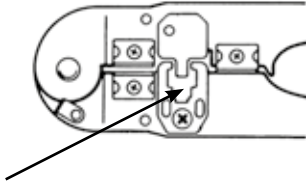

- Insert a plug into the plug holder of the crimping tool. It will click into place.
- Insert the prepared cable end into the plug, taking care to ensure the coloured inner conductors are in the same order and position each time.
- Squeeze the handles firmly to set the contacts and secure the cable.



CONTACT US...

Reece Group Pty Ltd  
118 Burwood Highway  
Burwood, Victoria 3125,  
Australia  
Tel: 1800 032 566  
Made in PRC