



# WATER CONTROL SYSTEMS

## 600HLR Series PRV

## 15-50mm

### Installation, Maintenance & Troubleshooting Instructions

#### Installation Instructions

1. This valve should be installed by a qualified licensed plumber.
2. Install valve in line with arrow on valve body pointing in direction of flow.
3. Before installing reducing valve, flush out line to remove loose dirt and scale which might damage seal ring and seat.
4. All valves will be furnished with stock settings to reduce to 350kPa.
5. To re-adjust reduced pressure, loosen outer locknut and turn adjustment bolt clockwise (into bell housing) to raise reduced pressure, or counterclockwise (out of bell housing) to lower reduced pressure.

**NOTICE:** Annual inspection and maintenance is required of all plumbing system components. To ensure proper performance and maximum life, this product must be subject to regular inspection, testing and cleaning.

**REGULATORS IN SERIES:** Where the desired pressure reduction is more than a 3 to 1 ratio (i.e. 1200kPa to 400kPa), or where inlet pressure exceeds 1000kPa multiple regulators in series should be installed to prolong valve life. In these instances, you may require 2 x 600HLR valves in a series, with the first set at 875kPa, and the second set at 500kPa or 530kPa.

**CAUTION:** Any time a reducing valve is adjusted, a pressure gauge must be used downstream to verify correct pressure setting. Do not bottom out adjustment bolt on bell housing. Valve may be installed in any position.

It is recommended regulators are protected from water hammer as this can cause premature wear on the valves and is not covered by warranty.

**NOTE:** Failure to adhere to installation instructions will void warranty

#### Typical Installations

- Unless otherwise specified, the assembly should be mounted at a minimum of 305mm and maximum of 762mm above adequate drains with sufficient side clearance for testing and maintenance

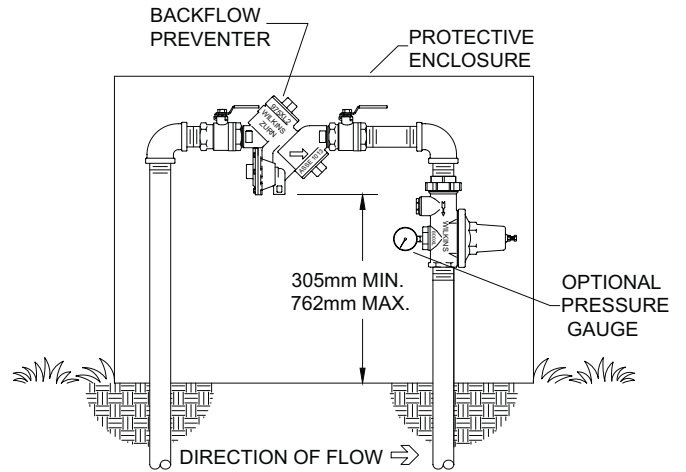

OUTDOOR INSTALLATION

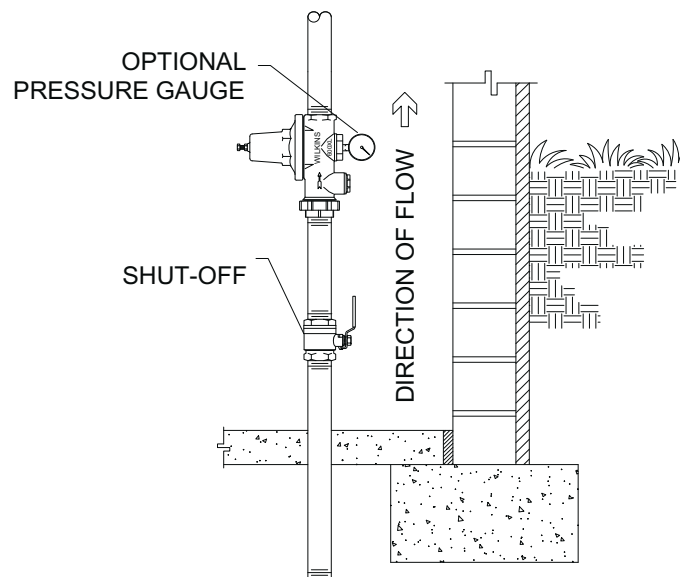

VERTICAL INSTALLATION

# Maintenance Instructions

## HOW TO MAKE REPAIRS:

(Shut off service before starting disassembly)

1. Open faucet on dwelling to remove line pressure.
2. Note distance that adjustment bolt protrudes from bell housing. Loosen locknut on adjustment bolt, then turn adjustment bolt out of bell housing until free of spring tension.
3. Loosen main cap and remove counterclockwise.
4. Loosen plunger and remove counterclockwise. Remove old seal ring then insert new seal ring.
5. Loosen strainer cap counterclockwise and remove screen.
6. Unscrew bell housing counterclockwise and remove spring, spring disc and friction ring.
7. Remove stem assembly from regulator. Inspect area in body where stem o-ring guides for pitting or scratches. Smooth bore with emery cloth if needed. This area must be smooth for the valve to function correctly.

## TO REASSEMBLE:

1. Open shut-off valve slowly and flush body and line of any debris.
2. Assemble new stem unit using new stem, o-ring, diaphragm, diaphragm disc and diaphragm bolt/nut. Tighten bolt/nut securely (**CAUTION:** Be sure the rounded edge of the diaphragm disc is next to the diaphragm).
3. Lubricate o-ring with grease supplied in repair kit and install stem unit in body.
4. Centre washer on stem. Screw plunger into stem unit.
5. **CAUTION:** Do not over tighten plunger; it is possible to break the threaded end of the plunger.
6. Install new screen, cap gaskets and replace caps by tightening clockwise.
7. Turn adjustment bolt into bell housing to old setting then enter dwelling and turn on several faucets.
8. Turn on water service. Let water run for several seconds then turn off faucets in dwelling.
9. Adjust the regulator to desired pressure by turning adjustment bolt clockwise (into bell housing) to raise pressure or counterclockwise (out of bell housing) to lower pressure. **It is recommended a pressure gauge be installed downstream of the regulator to ensure pressure is reduced below 500kPa.** **NOTE:** When reducing pressure, open a downstream faucet to relieve pressure.
10. Tighten locknut when desired pressure is achieved.

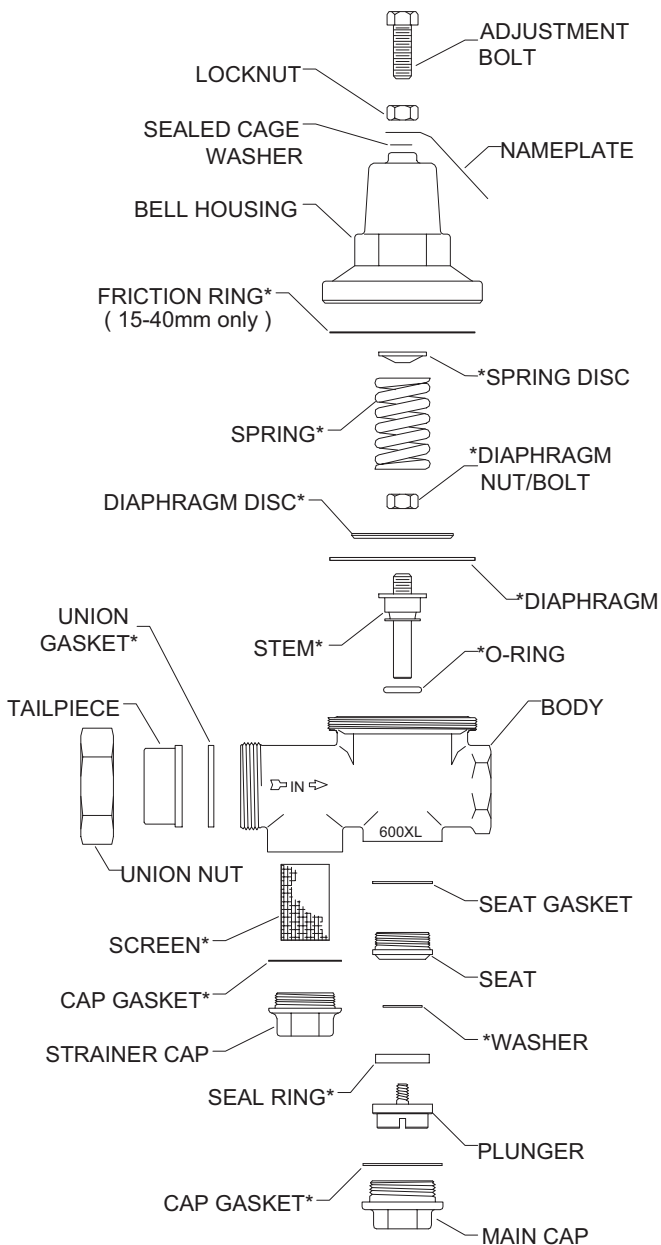

\* INDICATES PARTS SUPPLIED IN REPAIR KITS  
(spring disc not included in sizes 40 & 50mm)

# Troubleshooting

Pipelines in a water supply system must be of sufficient carrying capacity to maintain adequate pressure at the most remote or highest fixture. Relatively high service pressures which can create high water velocities in pipe lines would allow use of smaller pipes to satisfy fixture use. However, high velocity tends to cause whistling and humming. Reduction of pressure by the use of a pressure reducing valve, in an attempt to eliminate such a condition, may reduce pipe line capacities below that which is adequate for maximum probable use. When high service pressures are in effect, either continuously or periodically, the application of a pressure reducing valve will be successful only when the installed pipe line is of adequate size to satisfy the system demand at the lower pressure. When actual water demands are unknown, the valve size should be no less than the existing pipe size.

## PROBLEM

1. Pressure creeps or builds up in system above the setting of pressure reducing valve.

## POSSIBLE CAUSE OR CAUSES

- A. Thermal expansion of water as it is being heated.
- B. Foreign matter on seating face of seal ring.
- C. Cut, worn or chipped seal ring.
- D. Cut or worn stem o-ring or worn o-ring groove.

## SOLUTION

- A. This is a natural consequence. It may happen each time that the heater runs. A pressure relief valve or expansion tank must be installed. This will not prevent pressure rise but should limit it to a safe level.
- B. Flush the reducing valve by opening one or two fixture outlets wide. If this does not correct the problem, remove seal ring for cleaning.
- C. Replace with new seal ring. Temporary repairs may be made by turning the seal ring over.
- D. Replace with new stem o-ring and/or cartridge.

## PROBLEM

2. Pressure and fixture flow is unsteady.

## POSSIBLE CAUSE OR CAUSES

- A. Low water supply pressure in mains caused possibly by high area demand during certain periods of the day.
- B. Heavy periodic demands by appliances in the house.

## SOLUTION

- A. This is a water department problem. It is due to the mains being inadequate for the demands made on them.
- B. House service lines may at times be inadequate for the load. Size of some pipelines may need to be increased. Pressure setting of reducing valve may be too low.
- C. Try increasing pressure before changing pipelines

## PROBLEM

3. Small, inadequate flow from fixtures

## POSSIBLE CAUSE OR CAUSES

- A. Pipelines to fixtures may be too small or house main supply may be inadequate for normal fixture demand.
- B. Heavy periodic demands by appliances in the house.
- C. Screen clogged with debris.

## SOLUTION

- A. It may be necessary to increase pipe sizes only in some sections of the system leading to the offending appliances or fixtures. Increasing the house service mains might be necessary if small supply is general at all fixtures.
- B. Raise pressure gradually by readjusting valve until this point is determined.
- C. Clean screen.

## PROBLEM

4. Valve appears to be noisy; hums, whistles or chatters.

## POSSIBLE CAUSE OR CAUSES

- A. Hum or whistle is usually caused by a high velocity of flow in pipelines causing vibration.
- B. Chatter usually originates with worn seat washer or loosely installed seal ring.

## SOLUTION

- A. Pipelines could be small or too light. Reducing valves could be too small. Pipes and valves being small would accentuate this condition.
- B. Inspect seal ring. If a deep channel appears on seal ring face, replace or use the opposite side.
- C. Frequently noise appears in a faucet or appliance and seems to originate from the reducing valve. There is a general tendency to use streamline piping of a relatively small size. Velocity is naturally high and noise of fast moving water is not unusual.

# Specification

## MODEL 600 FEATURES

Max. Working Water Pressure	2100kPa
Max. Working Water Temp	60°C
Max. Working Water Temp - High Temp	82°C
Reduced Pressure Range	70-860kPa
Maximum Reduction	3 to 1

**CAUTION:** The maximum reduction a pressure reducing valve can deliver is 3 to 1 (i.e. 1200kPa to 400kPa). Additional reduction will require the use of another valve to step the pressure down.

**Eg. 2 x 600HLR valves in a series, with the first set at 875kPa, and the second set at 500kPa or 530kPa.**

**NOTE:** In most installations, 1 x 20mm valve will accommodate the low flow rates of a 32mm to 50mm valve. If in doubt please discuss your installation with your local Reece branch to investigate with Zurn.

# Performance Characteristics

SIZE	MIN.FLOW RATE
32mm	13.8 LPM (Litres per minute)
40mm	22.8 LPM
50mm	31.8 LPM
65mm	45.6 LPM
80mm	58.8 LPM

# Flow Characteristics

## MODEL 600HLR (STANDARD & METRIC)

