

NOTE: REGAL AUSTRALIA IS HAPPY TO PROVIDE TECHNICAL ASSISTANCE TO OUR CUSTOMERS IN MANY AREAS. HOWEVER, SINCE REGAL AUSTRALIA IS NOT AWARE OF ALL DATA CONCERNING THE USE AND APPLICATION OF THIS MOTOR, THE SUITABILITY OF THE MOTOR FOR THE APPLICATION MUST BE DETERMINED BY AND IS THE RESPONSIBILITY OF THE CUSTOMER.



MOTOR SPECIFICATION

CUSTOMER					
CUSTOMER P/N					
QR No.		CAPACITOR	uf / V		
POWER OUTPUT	60W	START	NIL		
MOTOR TYPE	SH/POLE	RUN	NIL		
SUPPLY	VOLTS	HERTZ	PHASE	POLES	
	240	50	SINGLE	4	
ENCLOSURE	TOTALLY ENCLOSED				
SPEED (RPM) AT RATED OUTPUT	1300	WINDING TYPE			
ROTATION	CLOCKWISE (DRIVE END)				
INSULATION CLASS	F 155	DUTY	AOM		
THERMAL PROTECTION	AUTO RESET				
RATED CURRENT	1.15	AMPS AT RATED OUTPUT			
APPLICATION	FAN DRIVE				
MOUNTING	STUDS IN ENDSHIELD				
BEARING & LUBRICATION	608ZZ WIDE RANGE, LONG LIFE		ROTOR END RINGS		
SUPPLY LEAD	COLOUR	PVC GREY		ALUMINIM GRADE	BP170
	LENGTH	150	+50 -0 (45±5 STRIPPED)	RADIAL SKEW ANGLE	25° ±1.0°
	TERMINALS	BOOTLACES		END RING No.1 DRAWING	306-073-31
	Q.C. HOUSING	NIL		END RING No.2 DRAWING	306-073-30
✓ MULTI STRAND					
□ SINGLE CORE					
EARTH PROVISION	VIA SUPPLY LEAD				
BASIC BUILD SPECIFICATION			WINDING		
PERFORMANCE SPECIFICATION			WIRE	0.4PEI-2	
SHAFT MATERIAL	303SS		TURNS	350	
CONNECTION DIAGRAM	NIL	PAINT SPEC	NIL	OHMS	31

SURFACES MUST BE THOROUGHLY CLEANED PRIOR TO AFFIXING LABELS AT BOTH ENDS

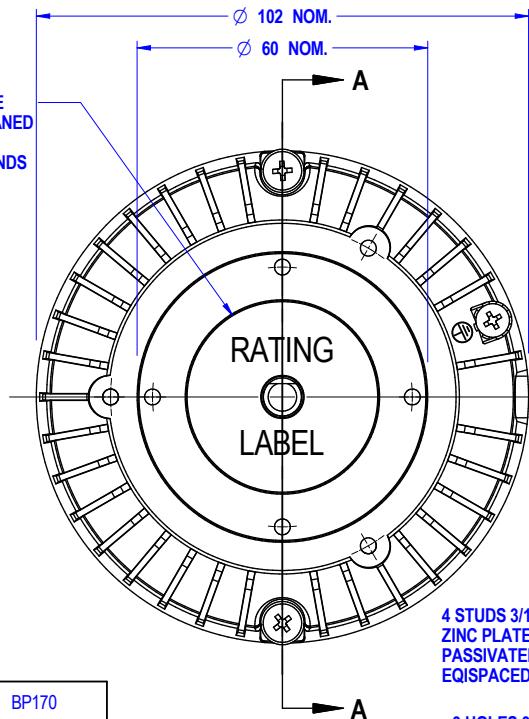

DO NOT SCALE PRINT

NOTE: REFER TO DE0034 FOR ENDSHIELD MACHINING.

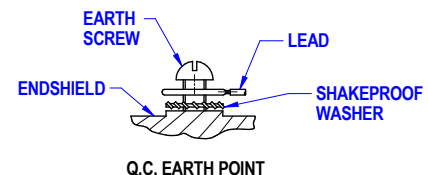
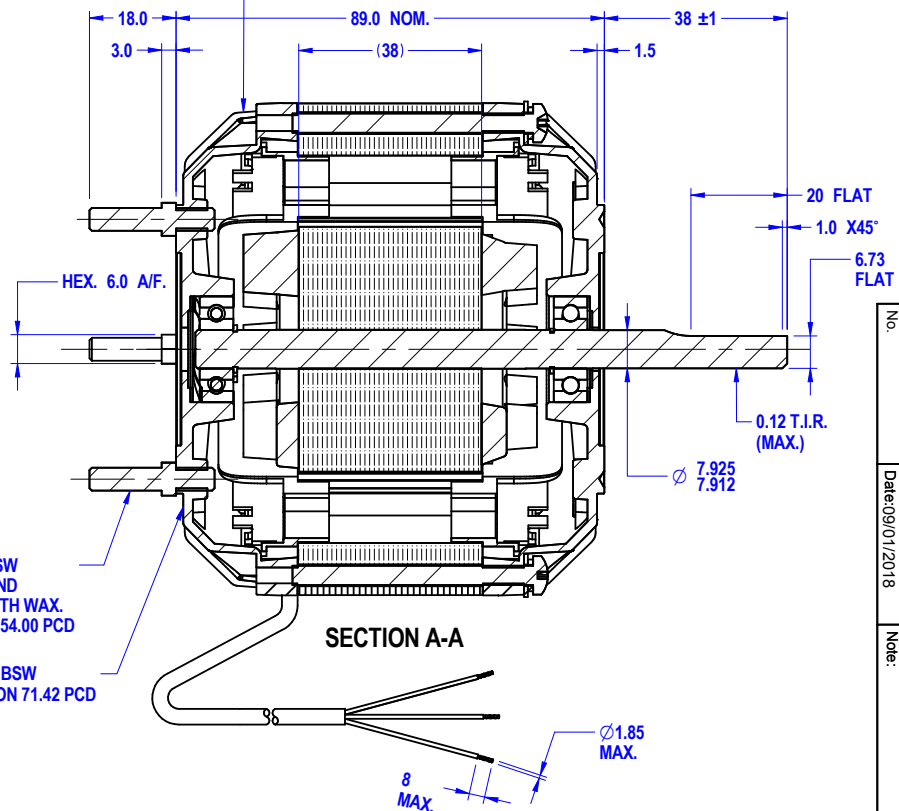

- SPECIAL REQUIREMENTS**
- 1) PLACE IN PLASTIC BAG AND ATTACH TO LEAD
4 - NUTS 3/16" BSW
4 - SHAKEPROOF EXTERNAL WASHER 5mm I.D.
 - 2) SHAFT MATERIAL 45 STEEL.
 - 3) SINGLE CARTON, 6-MOTORS IN PLAIN BOX.

DIMENSIONS IN mm UNLESS OTHERWISE SPECIFIED	
GENERAL TOLERANCES	
LINEAR:	X = ±1.0
	XX = ±0.25
	XXX = ±0.1
ANGULAR:	X = 2°
	XX = ±0.5°
SURFACE FINISHES IN MICRO METRES. MAX 3.0	
SYMBOLS - A.S. 1100	
This drawing remains the property of Regal Australia Pty. Ltd. No part or parts of this drawing may be reproduced without written permission.	

MAT'L		
FINISH		
DRAWN	MURFETTR	07/05/07
CHECKED		
RELEASED		
SCALE		

REGAL

19 Corporate Avenue
Rowville, Melbourne
Victoria 3178, Australia

FRAME	MOTOR		REVISION
STATUS	4P 40W		
SHEET	DWG. NO.		
A3	50D505-71CT		C

MIC No. _____
By: Sritchal Date: 09/01/2018
MIC No. _____
C: SHOWN SECTION A-A