

# RAMTAPS - YEVA WALL MIXER WITH RECTANGULAR WALL PLATE

## SPECIFICATIONS

Recommended use	Domestic and Hotel
Colour availability	Chrome
Pressure rating	Maximum Hydrostatic Pressure 1000kpa Minimum Hydrostatic Pressure: 150kpa Note: As per AS3500 pressure must be limited to 500 kpa on any new home, extension or renovation, and any tapware fitted with flow restrictors must be limited to 500 kpa. Note: For best performance and longer life we recommend max 500 kpa
Temperature rating	Maximum water temperature 80° Minimum water temperature 1°
Suitable Hot Water Unit	Storage tank: Yes Continuous Flow: Yes Gravity Feed: Not recommended
Standards	AS/NZS 3718

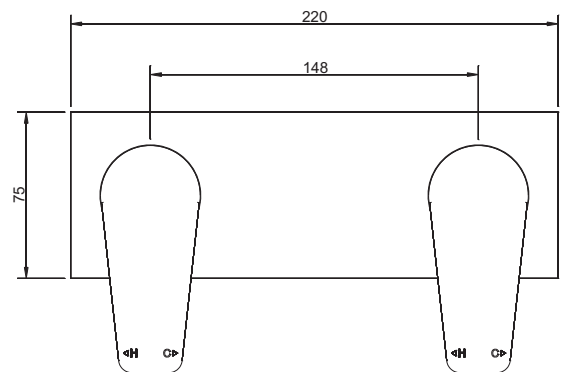

## CARE DETAILS

### Cleaning Recommendations

Any bathroom product should not be cleaned with abrasive materials eg. steel wool/scourers. Do not use any corrosive or abrasive cleaning agents containing acids or scouring agents. Bleaches can also discolour products and therefore should not be used. Damage caused by any improper treatment is not covered by the product warranty - refer to Warranty Conditions on the last page.

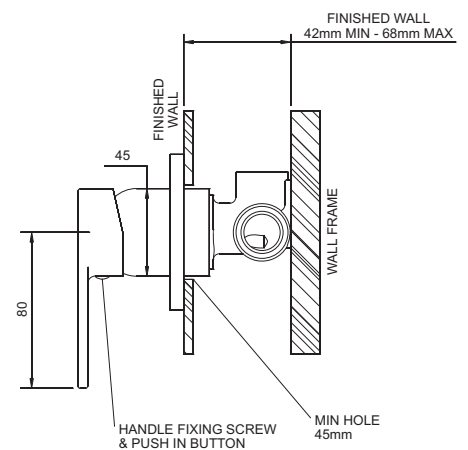

**Disclaimer:**  
Products in this specification manual must by regulation be installed by licensed and registered trade people. The manufacturer/distributor reserves the right to vary specifications or delete models from their range without prior notification. Dimensions and set-outs listed are correct at time of publication however the manufacturer/distributor takes no responsibility for printing errors.  
Tech Page Version 2



# RAMTAPS - YEVA WALL MIXER WITH RECTANGULAR WALL PLATE

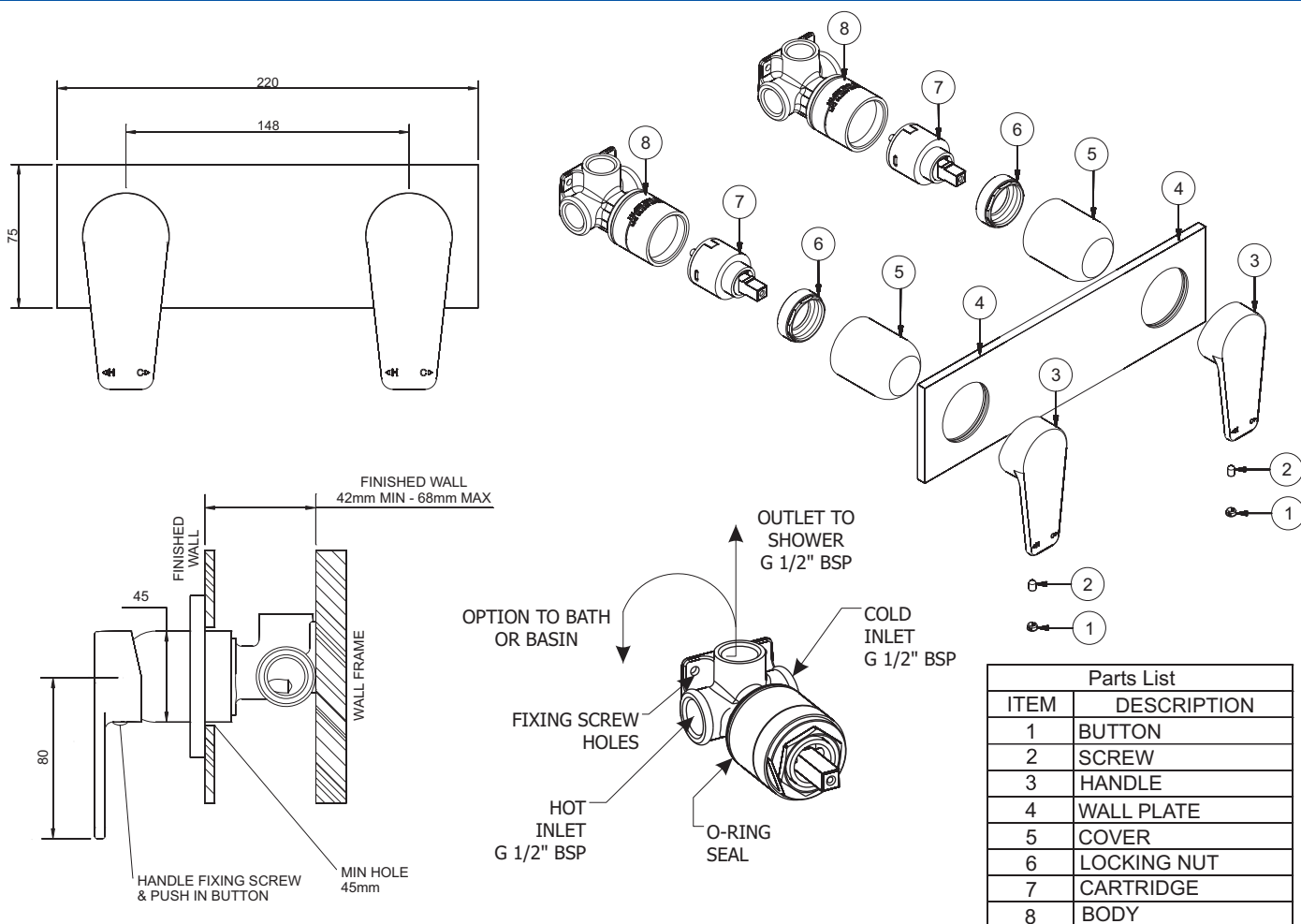

Parts List	
ITEM	DESCRIPTION
1	BUTTON
2	SCREW
3	HANDLE
4	WALL PLATE
5	COVER
6	LOCKING NUT
7	CARTRIDGE
8	BODY

## INSTALLATION INSTRUCTIONS

**Note:** It is a requirement of State Plumbing Codes that licensed plumbers carry out all tapware installations. All installations should comply with the relevant requirements of AS/NZS 3500 and local plumbing codes. Prior to installations of the mixer please flush all pipe work.

Ceramic Cartridges - Warranty claims will not be honoured where the ceramic cartridge has malfunctioned due to the presence in the water supply of;

- Copper tube pieces
- sand, dirt or stones
- thread tape
- other objects not normally present in potable water supplies.

**Important:** Your mixers comes to you already assembled and tested. We do not recommend the dismantling of any internal parts of the mixer due to the fact that it has been pressure tested and sealed to give you the best performance.

## Installation Procedure

1. During installation and testing make sure the mixer is in the closed position and the brass cover is removed to prevent damage.
2. When mounting the mixer on the wall frame, take note of the dimension shown so that the finished wall is correctly positioned as well as the centre distance between the bodies.
3. Connect water supply to the inlets as shown in the above diagram. When connecting, USE UNION CONNECTORS OR BRAZED JOINTS CONSTRUCTED AWAY FROM THE TAP. Brazed joints ie. Heat, made at the inlets and outlets will result in damage to the ceramic cartridge and void the warranty.
4. Must be installed with outlet **vertical** to ensure correct handle orientation.
5. Do not high pressure test the supply system with the outlet blocked and the tap open, as this may damage the ceramic cartridge.
6. To complete the installation check that the o-ring seal is in place and is not damaged. Then screw on the brass cover and press the wall plate over the cover firmly against the wall.
7. Fit the handle to the cartridge, securing it with the screw, and push in the button.
8. Open the handle when introducing the water supply.

# RAMTAPS - YEVA WALL MIXER WITH RECTANGULAR WALL PLATE

## REECE PRODUCT QUALITY GUARANTEE

### REECE PRODUCT QUALITY GUARANTEE

You have purchased a quality product from Reece Pty Ltd ABN 84 004 097 090 ("Reece"). This product is covered by a 15 year replacement product warranty and a 5 year warranty over spare parts and labour.

### 15 YEAR WARRANTY – DOMESTIC USE

This warranty covers faults in the product construction, material and assembly. Products which are within 15 years from the date of purchase, found upon inspection by an authorised Reece representative, to be defective in construction, material or assembly, will be repaired or exchanged with an equivalent product free of charge. Replaced items become Reece's property. This warranty also covers any spare parts included under "Manufacturer's Provisions" below.

All replacement products will be available for collection without charge to the customer at the nearest Reece branch to the customer's location, or elsewhere as agreed between the customer and Reece.

### Manufacturer's Provisions

The following spare parts are covered by a 15 year warranty:

- Mixer Cartridge
- Flexible Tails

### Labour and Spare Parts

The labour for the replacement of products and spare parts to which this warranty applies will be supplied by Reece or relevant supplier using licensed plumbers engaged by Reece or relevant supplier within 5 years from the date of purchase.

Spare parts other than those listed in the Manufacturer's Provisions above, which are within 5 years from the date of purchase found upon inspection by an authorised Reece representative to be defective in construction, material or assembly, will be replaced free of charge.

### Warranty Conditions

This warranty will apply only under all of the following conditions:

- The item has been installed by a licensed plumber
- The item has been installed for and subjected to domestic residential use only
- Failure is due to a fault in the manufacture of the product
- Proof of purchase (including the date of purchase) is provided
- The installation of the product is in accordance with the instructions provided

This warranty does not cover products purchased as an ex-display without being fully checked and tested for sale by the manufacturer.

This warranty does not include faults caused by:

- Unsuitable or improper use
- Incorrect installation or installation not in accordance with the instructions provided
- Installation or part installation by the purchaser or any person other than a LICENSED PLUMBER
- Normal wear and tear
- Inadequate or complete lack of maintenance
- Chemical, electrochemical or electrical influences
- Harsh detergents or abrasive cleaners used on product finishes

### 1 YEAR WARRANTY – COMMERCIAL USE

'Commercial' use is all use other than for normal domestic residential purposes, including use in non-business places as in public buildings, schools, sports centres and in establishments that contain private bathrooms with high frequency of use by many individuals, such as hotels, motels, retirement villages and hospitals.

The Commercial warranty covers this product against manufacturing faults in the construction, material and assembly of both the finished products and any spare parts for a period of 1 year from the date of purchase. Products and spare parts which are found upon inspection by an authorised Reece representative to be defective in construction, material or assembly will be repaired or exchanged free of charge. Replaced items become Reece's property. The labour for the replacement of products and spare parts to which this warranty applies will be supplied by Reece or relevant supplier using licensed plumbers engaged by Reece or relevant supplier. The Warranty Conditions and exclusions which apply to the non-commercial warranty also apply to this commercial warranty.

### EXCLUSIONS

To the fullest extent permitted by law, Reece excludes all liability for damage or injury to any person, damage to any property, and any indirect consequential or other loss or damage.

### CLAIM PROCEDURE

For all warranty queries customers are to contact the branch where the product was purchased. These details can be found on your purchase invoice.

Our goods come with guarantees that cannot be excluded under the Australian Consumer Law. You are entitled to a replacement or refund for a major failure and for compensation for any other reasonably foreseeable loss or damage. You are also entitled to have the goods repaired or replaced if the goods fail to be of acceptable quality and the failure does not amount to a major failure.



**Don't risk it, use a licensed plumber.™**

