

Roca

IN-WASH® ONA IN TANK BTW

A80313500R

INSTALLATION MANUAL

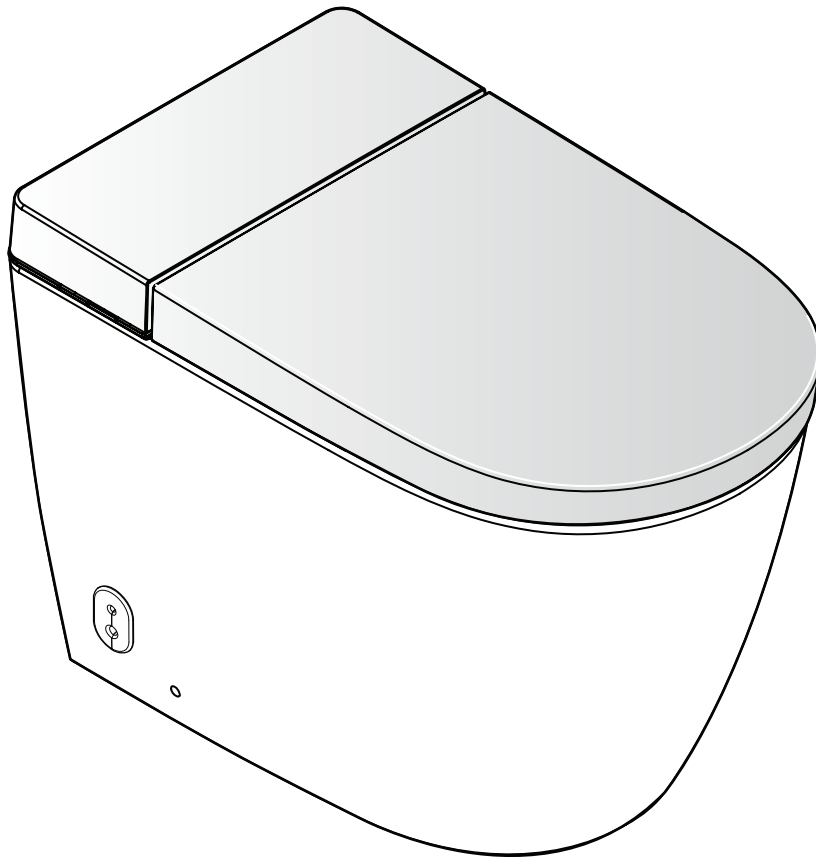

- This inwash bidet toilet is to be connected directly to mains supply. Does not require separate cistern or flush valve. The product must be installed by a licensed electrician according to AS/NZS 3000 - Australian wiring Rules.
- Water supply connection must be done by a licenced plumber in accordance to AS3500 and National Construction code Vol 3
- Before installation, read thoroughly this installation manual and the included safety precautions. Parts must be installed according to the instructions.
- Rain water, demineralized water, sea water or grey water are not suitable to operate this equipment. This product can only be connected to normal potable drinking water.
- Do not damage electrical connection components.
- The recommended water supply pressure is 150 KPa to 500 KPa. Operate equipment within the recommended water pressure.
- Water supply temperature must be between 4 - 40°C. Ensure the correct water temperature is maintained.
- Do not use a water hose other than the one provided with this product.
- Make sure that this product is correctly earthed to ground. (If the product is not earth-connected, there is a risk of electric shock).
- Prior to the installation, have an adequate electrical outlet available, according to the current local legislation.
- Dual check valve must be fitted before cistern stop.
- Please note this Bidet Douche Seat is approved under WMKA02321 and incorporates an integral airgap as high hazard protection in compliance to AS1172.1-2014, AS1172.2-2014. and WMTS 051. It meets the requirements of AS/NZS3500.1 and National Construction Code and no additional backflow device is required to be fitted (Apart from dual check valve supplied with unit).

Technical information	
Power Supply	220-240 ~ 50/60Hz
Power Wattage	1650W
IP Rating	IPX4
Note: Any electrical work connected on this project must be installed by qualified personnel, in accordance with AS/NZS 3000 Wiring Rules.	
Certification	
Watermark	AS 1172.1-2014(Amdt 1 2018) & AS 1172.2-2014(Amdt 1 2018) Certificate No. WMKA02321
RCM	



A According to current legislation

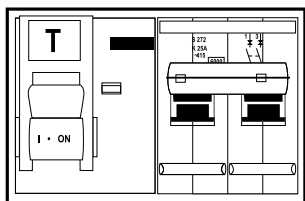

25A, IDn 0.03A

10A or 15A

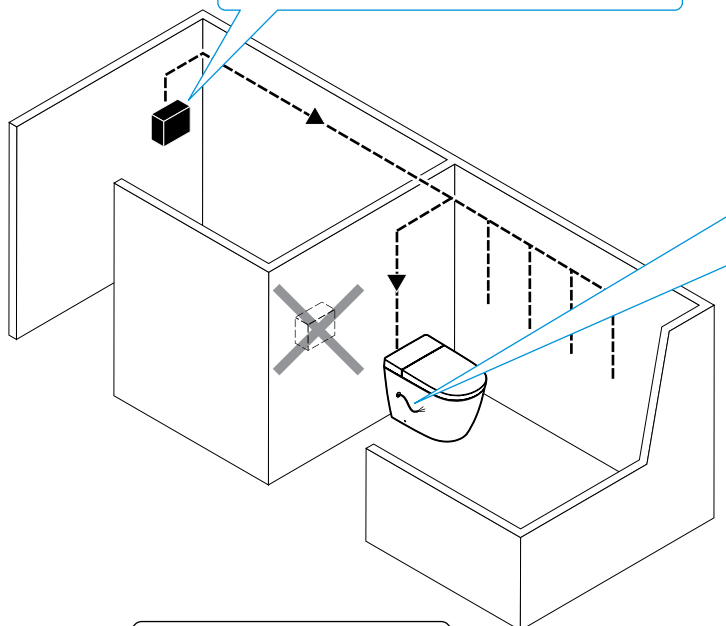
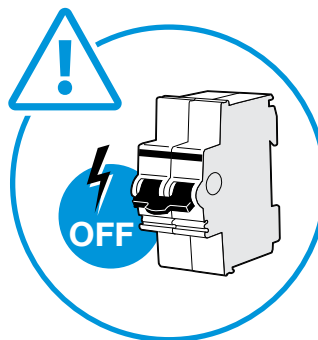
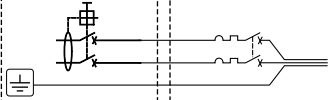

B Mandatory

3 x 1mm²

L Min. = 650 mm

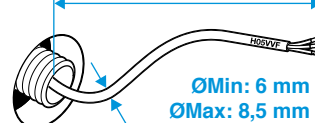

ØMin: 6 mm
ØMax: 8,5 mm

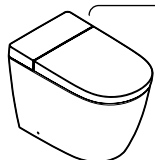
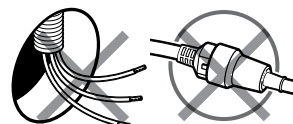

220-240~
50/60 Hz.
1650 W Max.

C



V = Volume

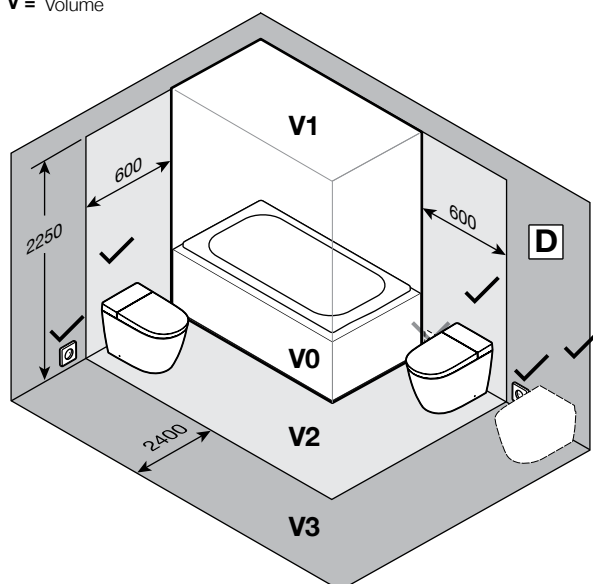

This electric toilet may be installed in volume 2, although if connected to a wall-socket, it shall always be installed in volume 3.
These recommendations are valid as long as the installation is compatible with the country and local regulations.
This product (IPX4) shall not be exposed to water jets for cleaning purposes.

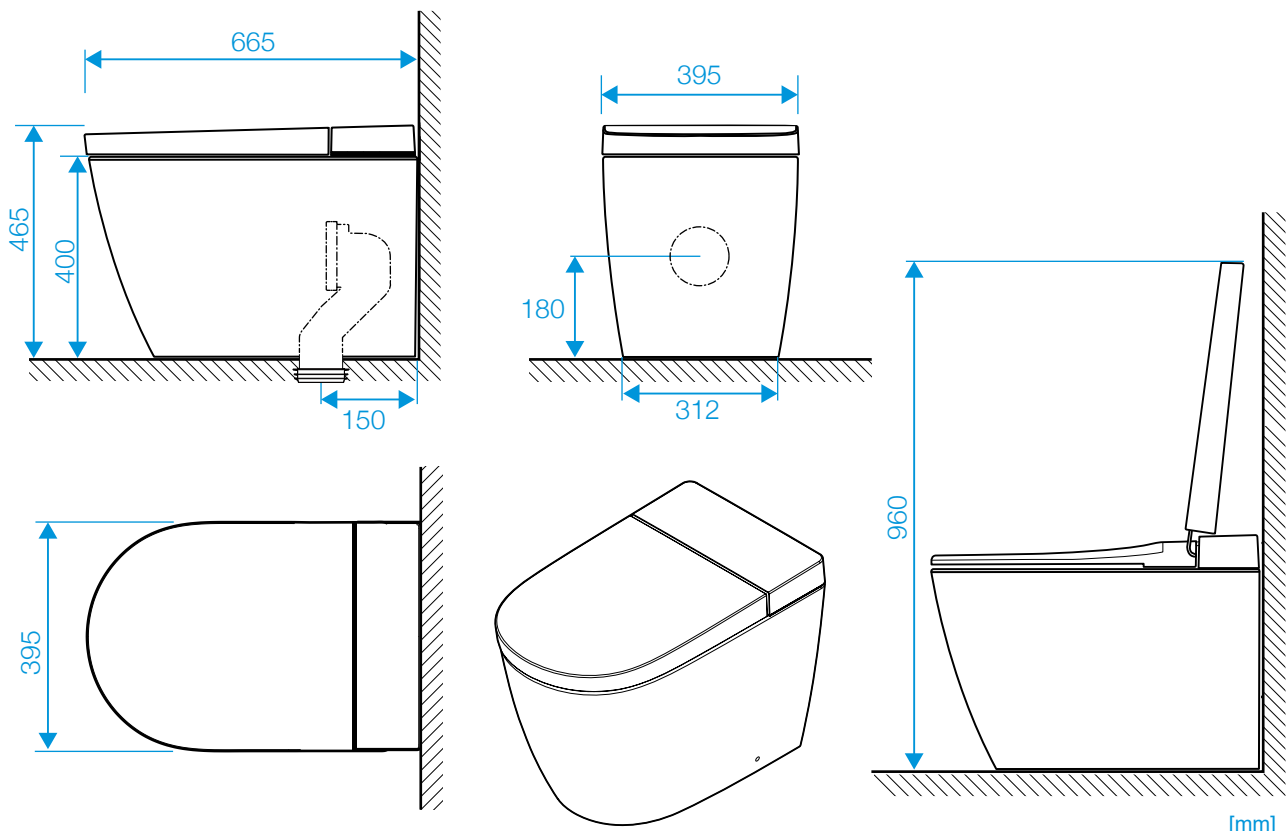

[mm]

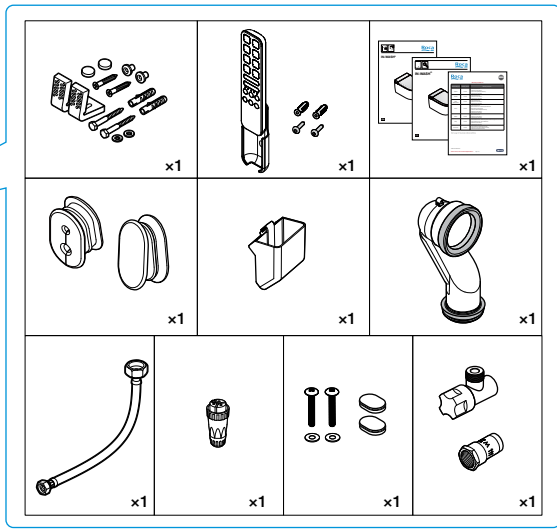
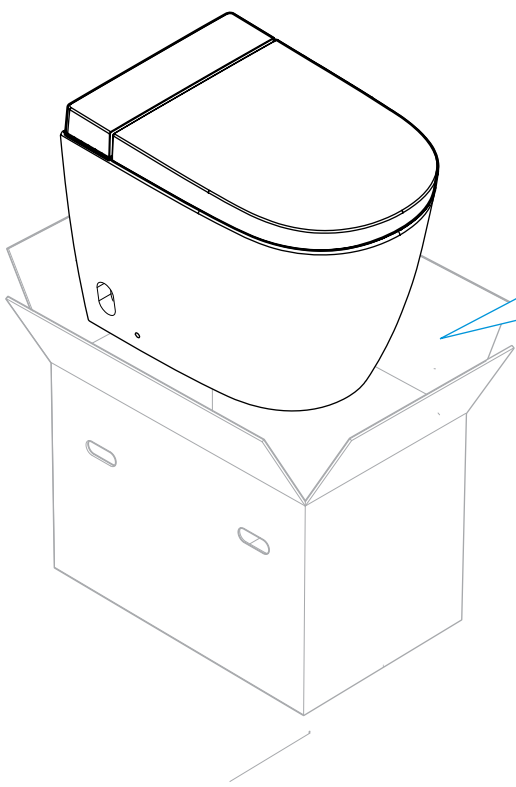

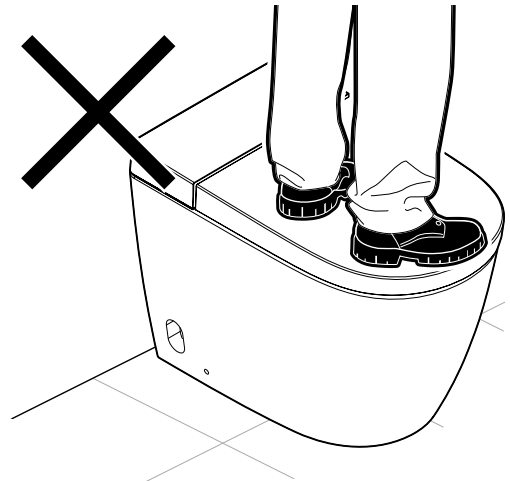
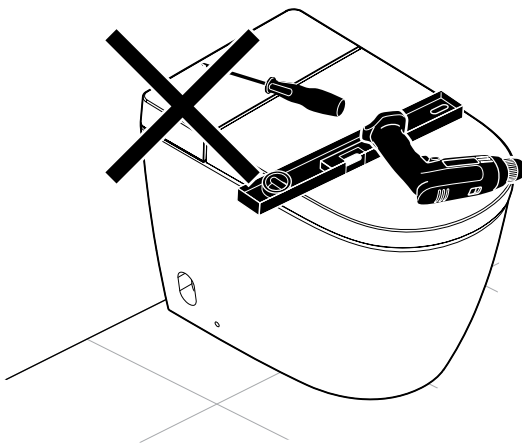
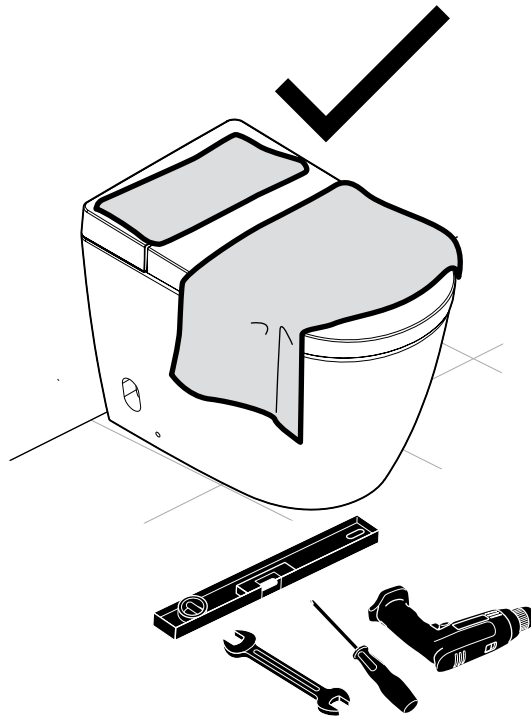
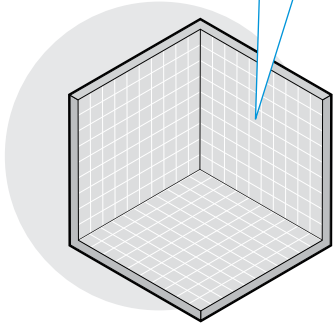
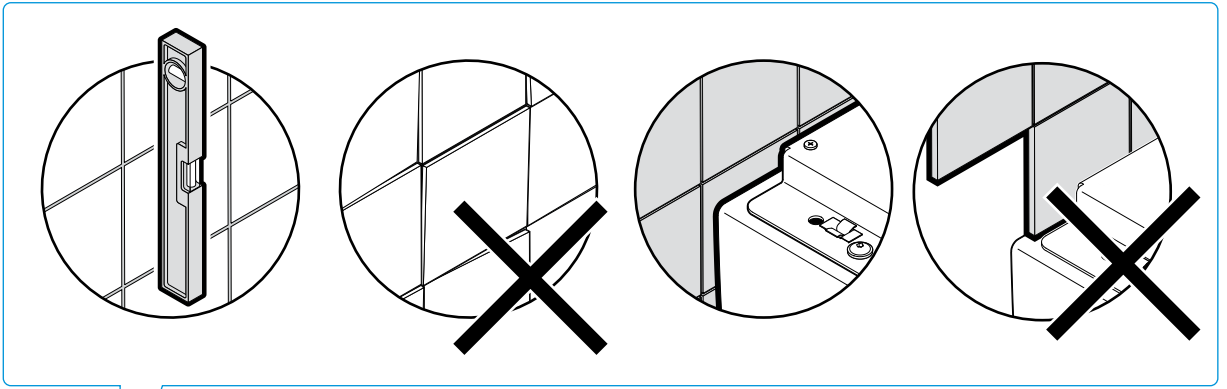

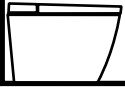

1 Water Supply Connection

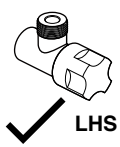
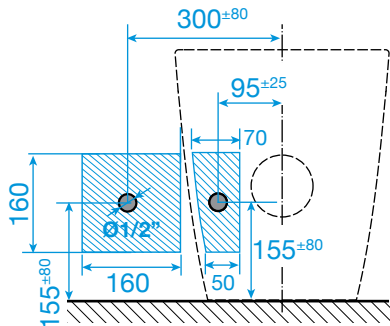
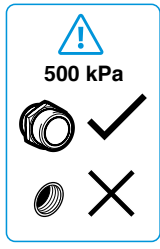

LHS Only

Can be Concealed or exposed

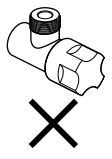
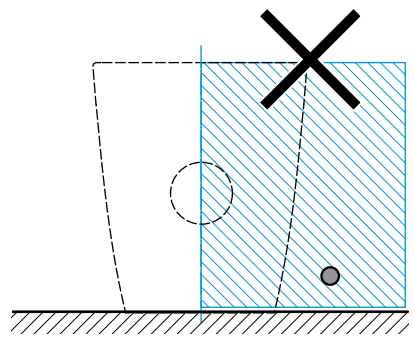

2 Electrical

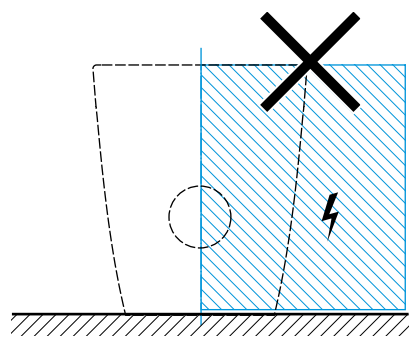
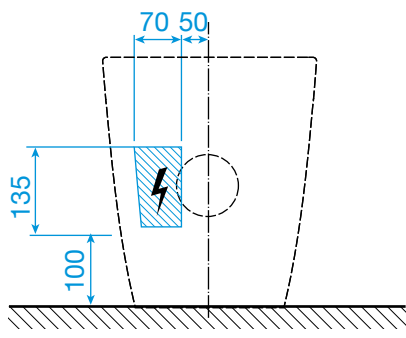

 Installation area



Not included with the product

1

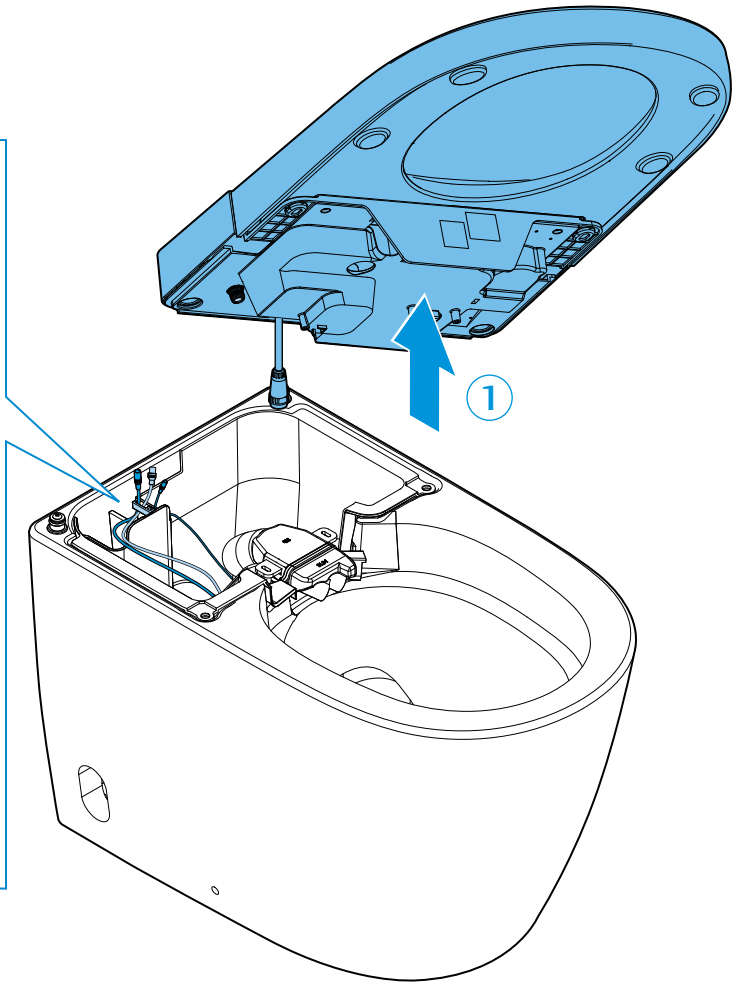
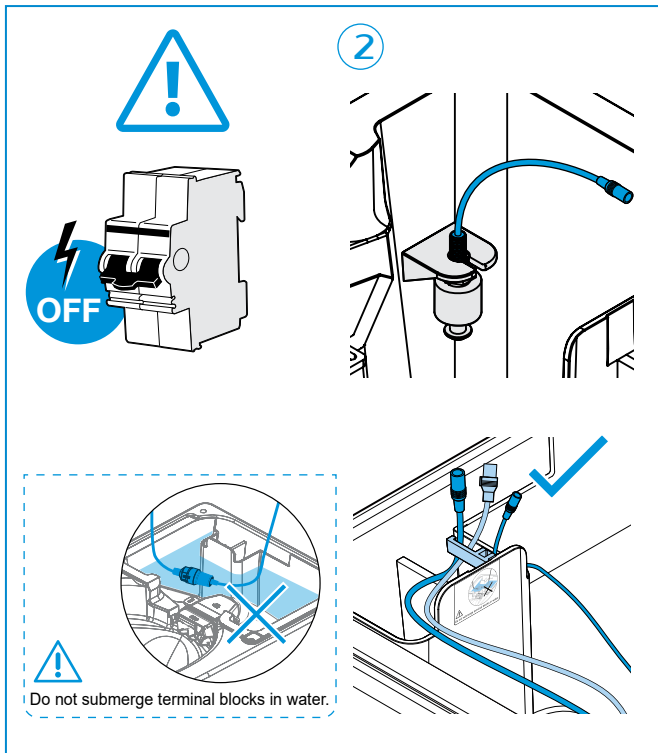

2

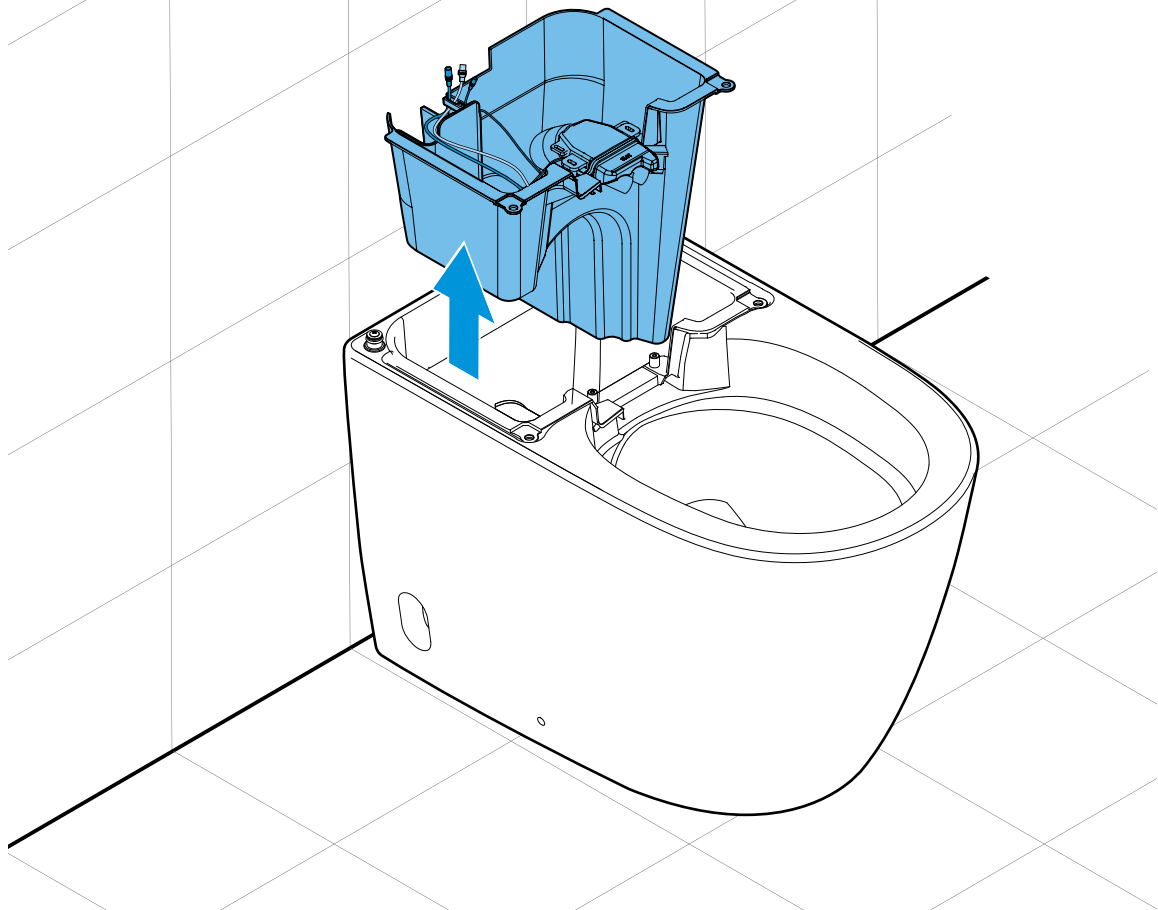

3

L Min. = 300 mm

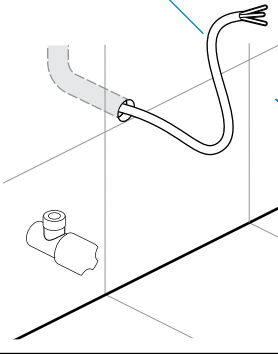

1



OFF

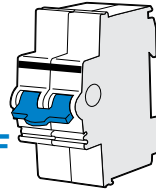

2

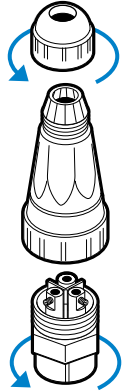

3

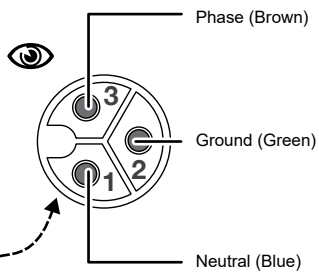
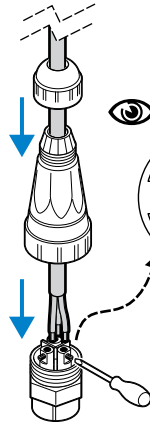

4

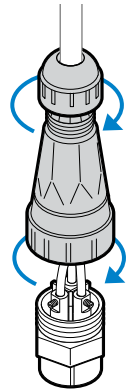

4

1

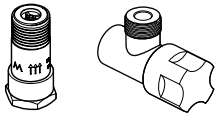

2

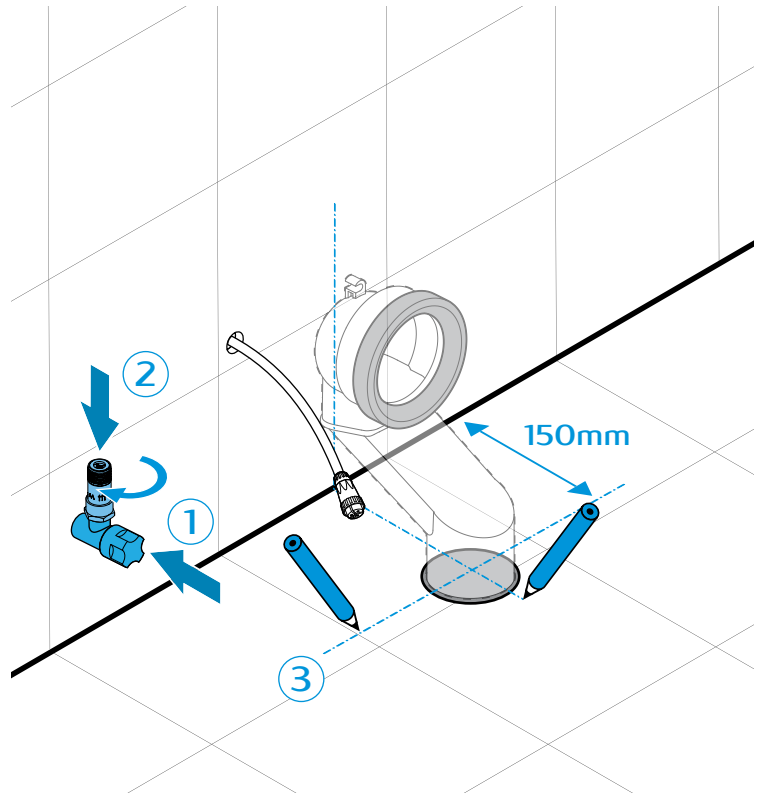
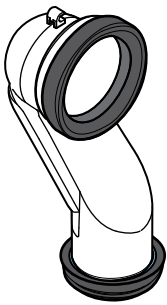

5

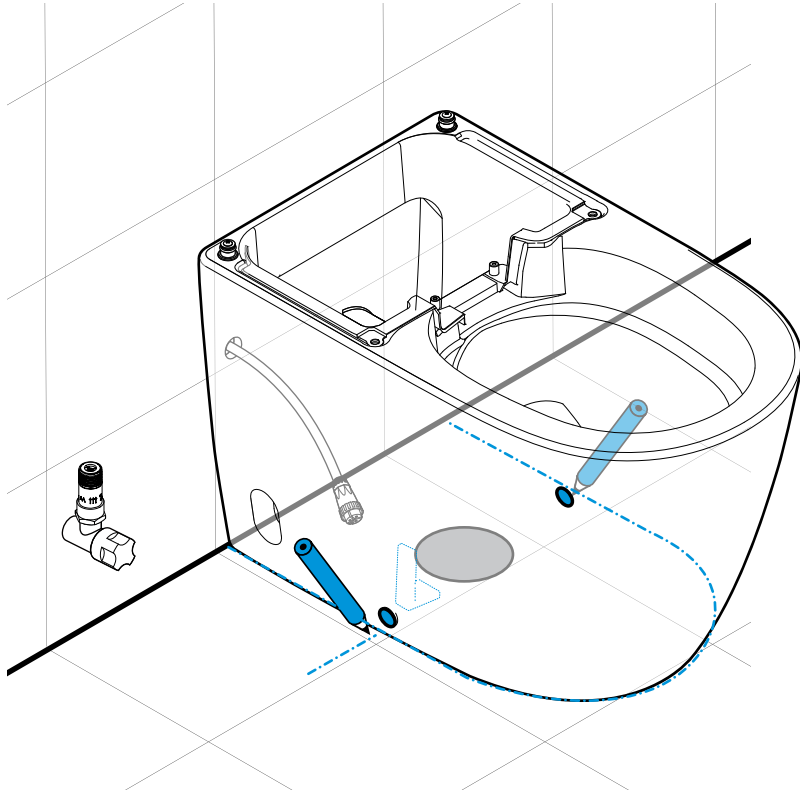

6

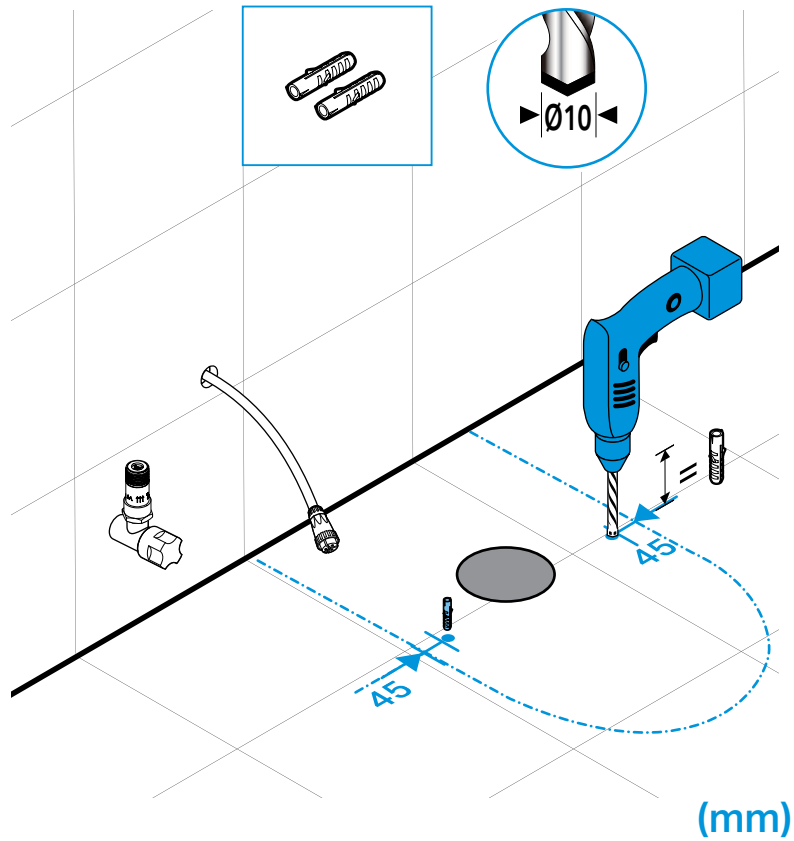

7

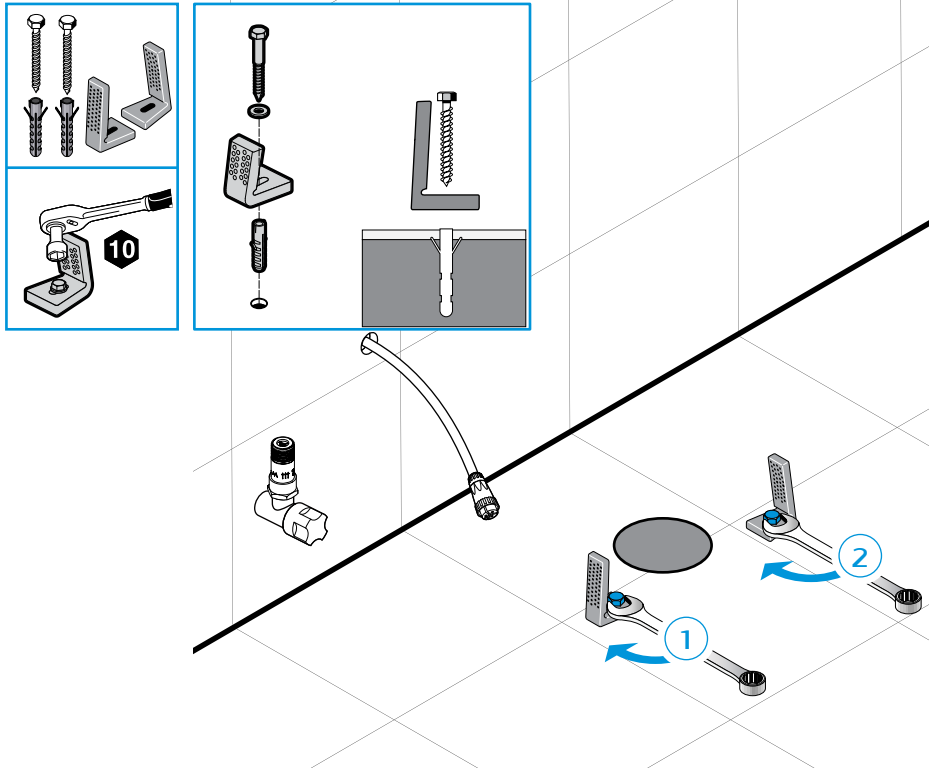

8

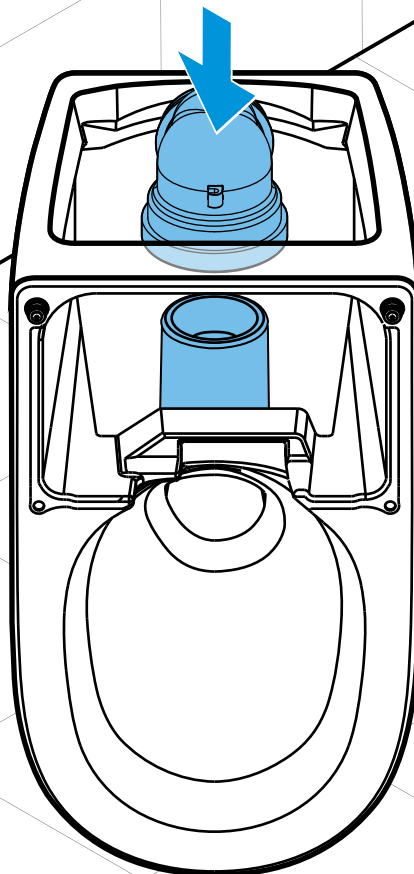
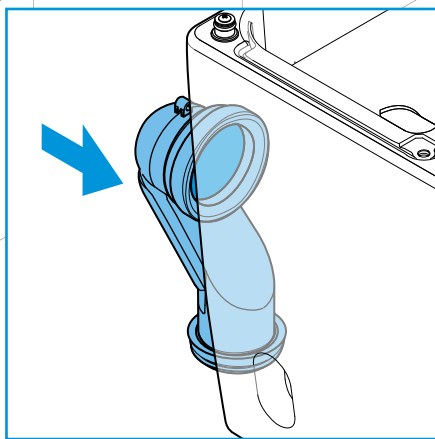

9

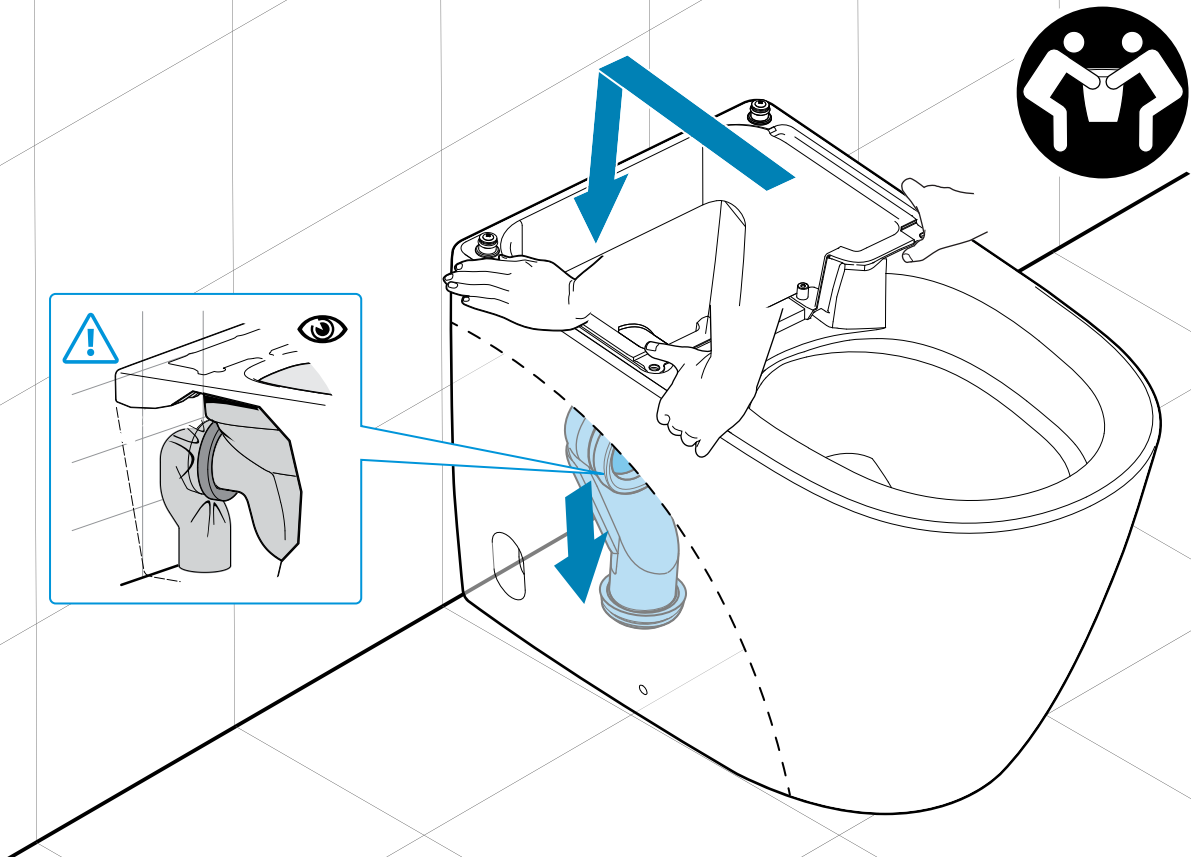

10

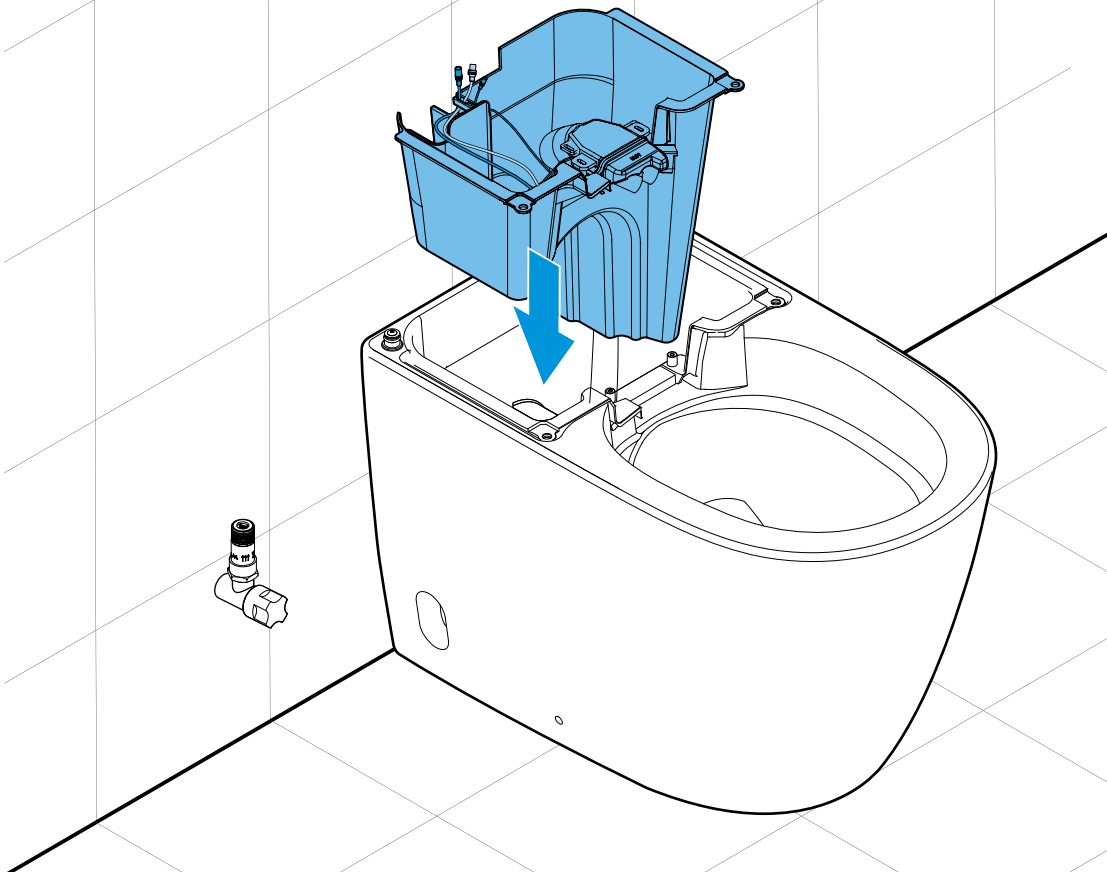

11

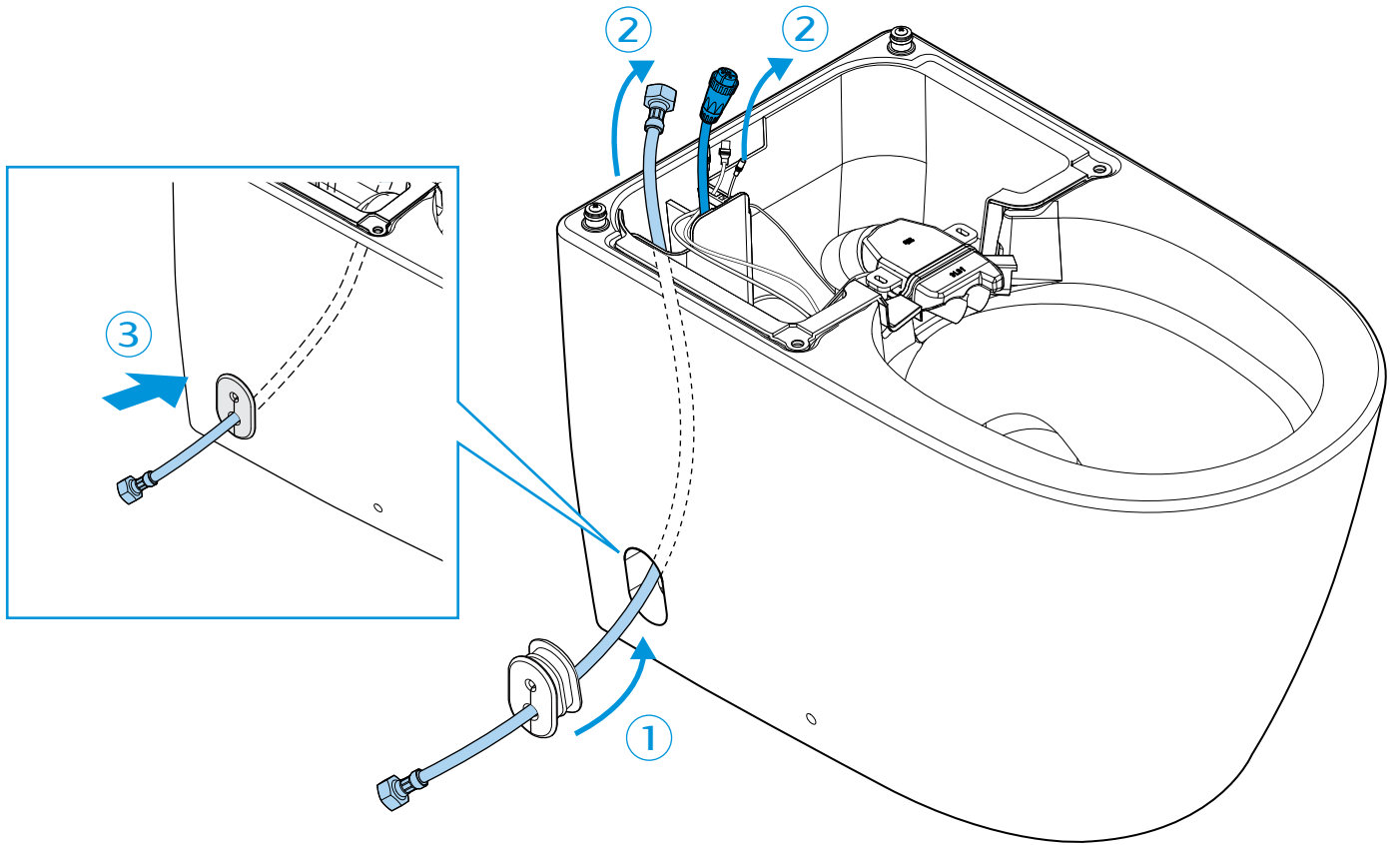

12

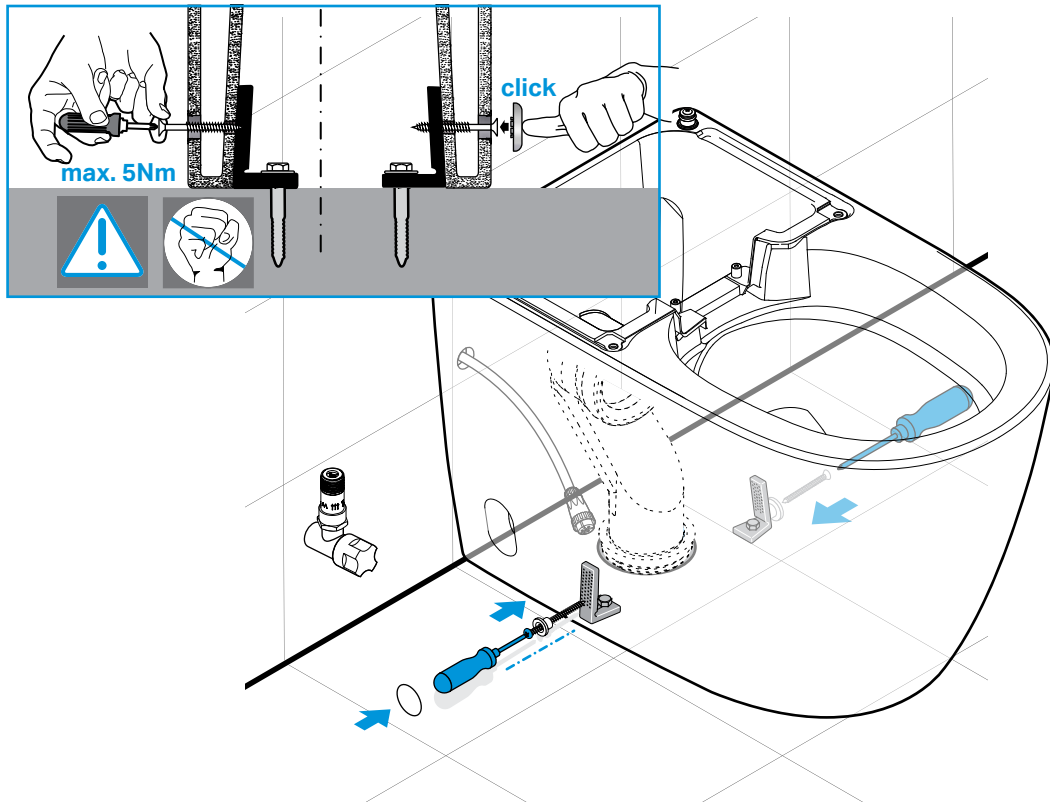

13

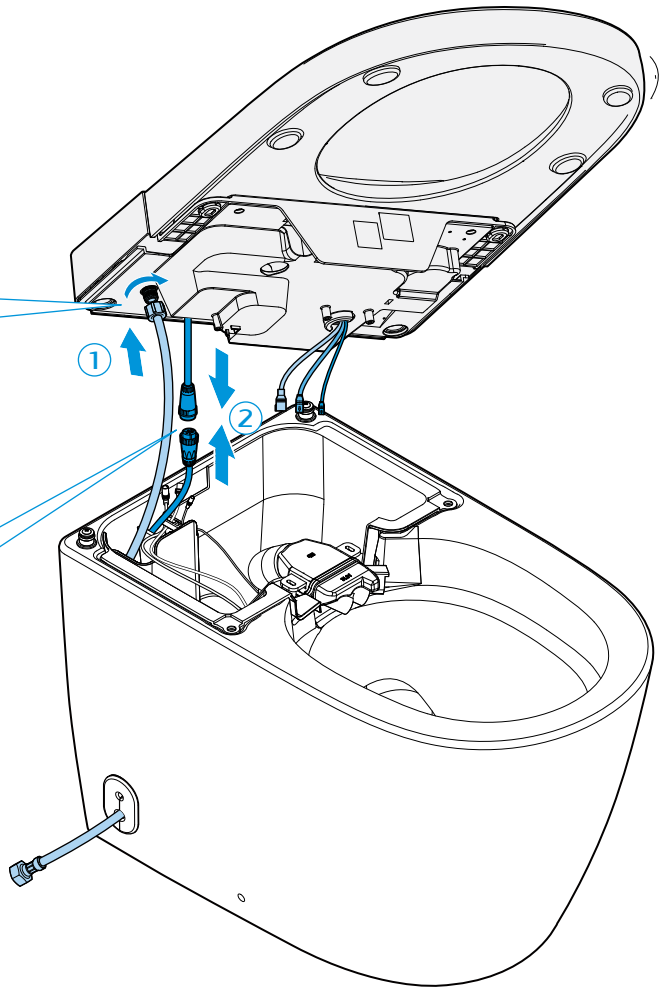
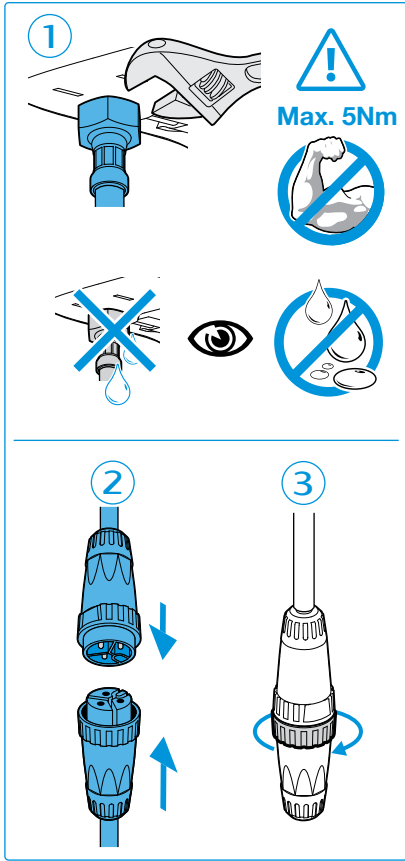

14

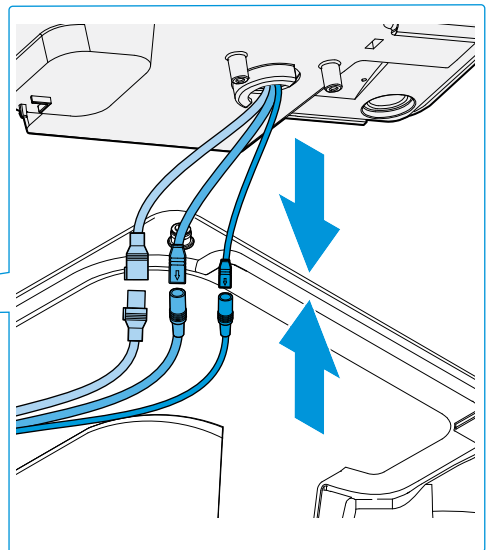
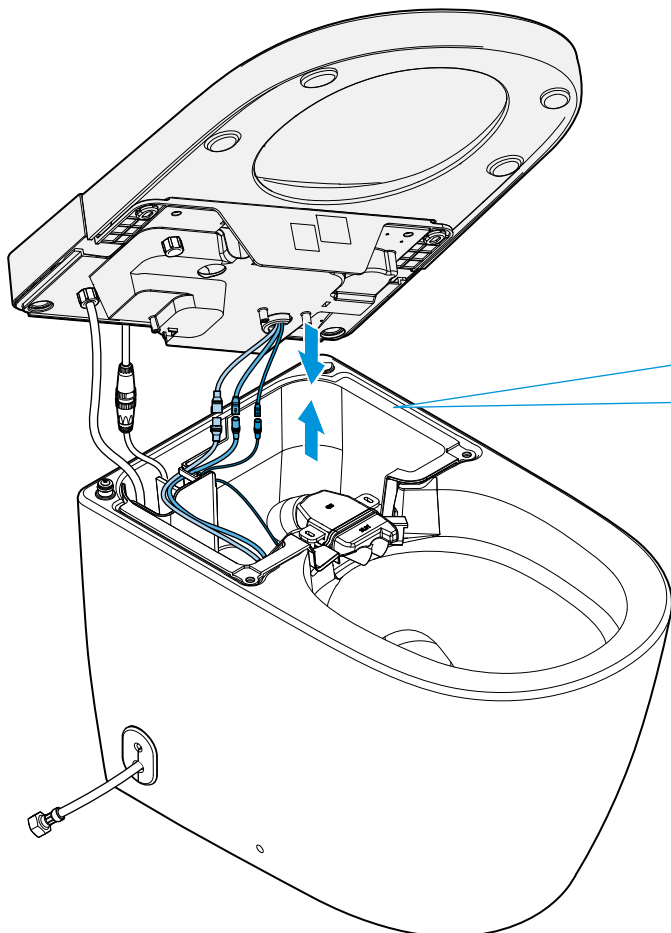

15

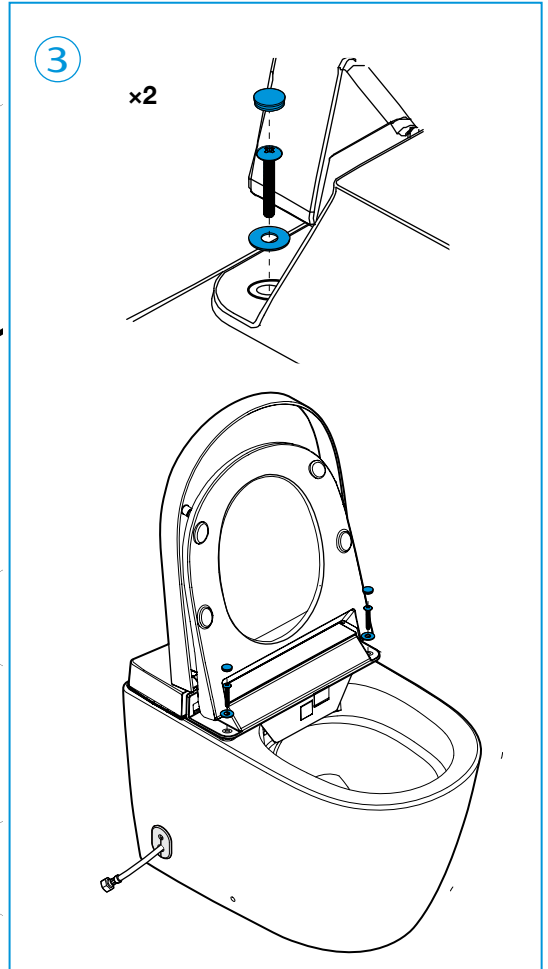
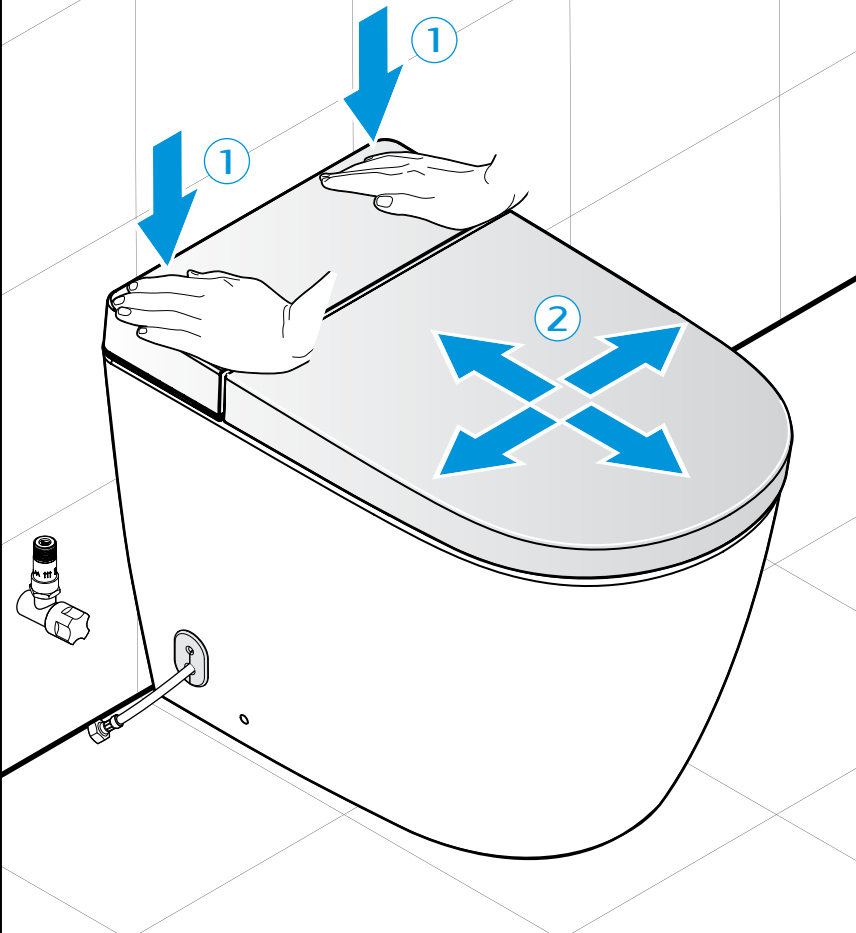

16

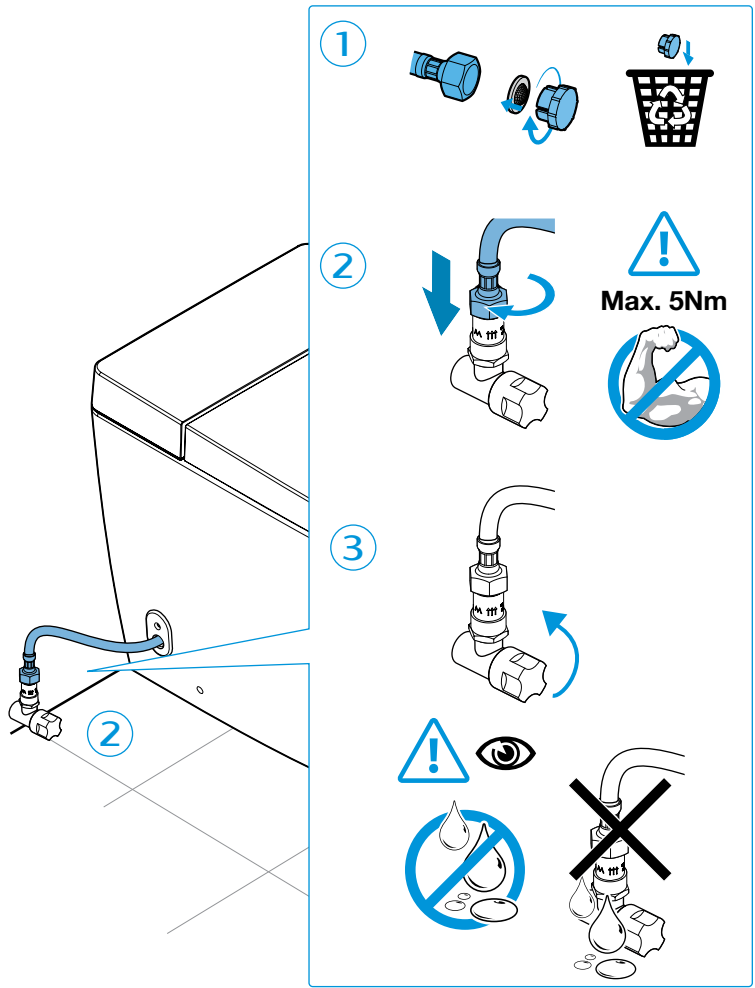
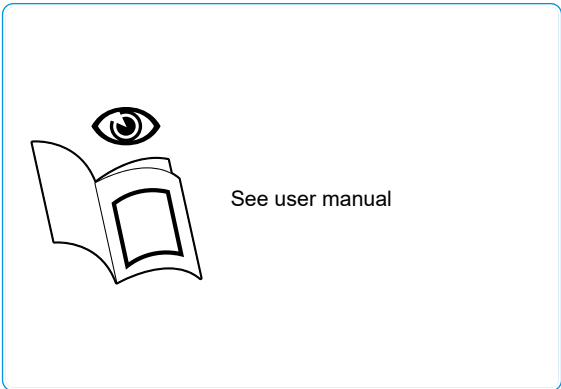
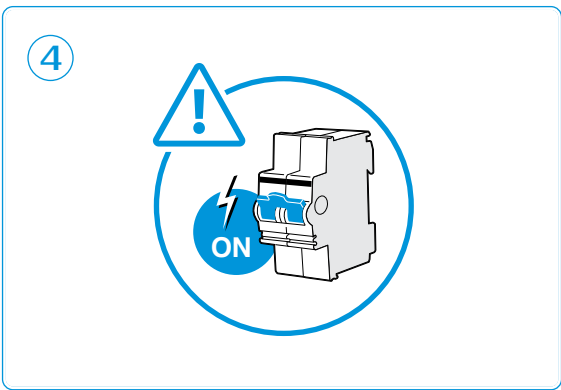

17

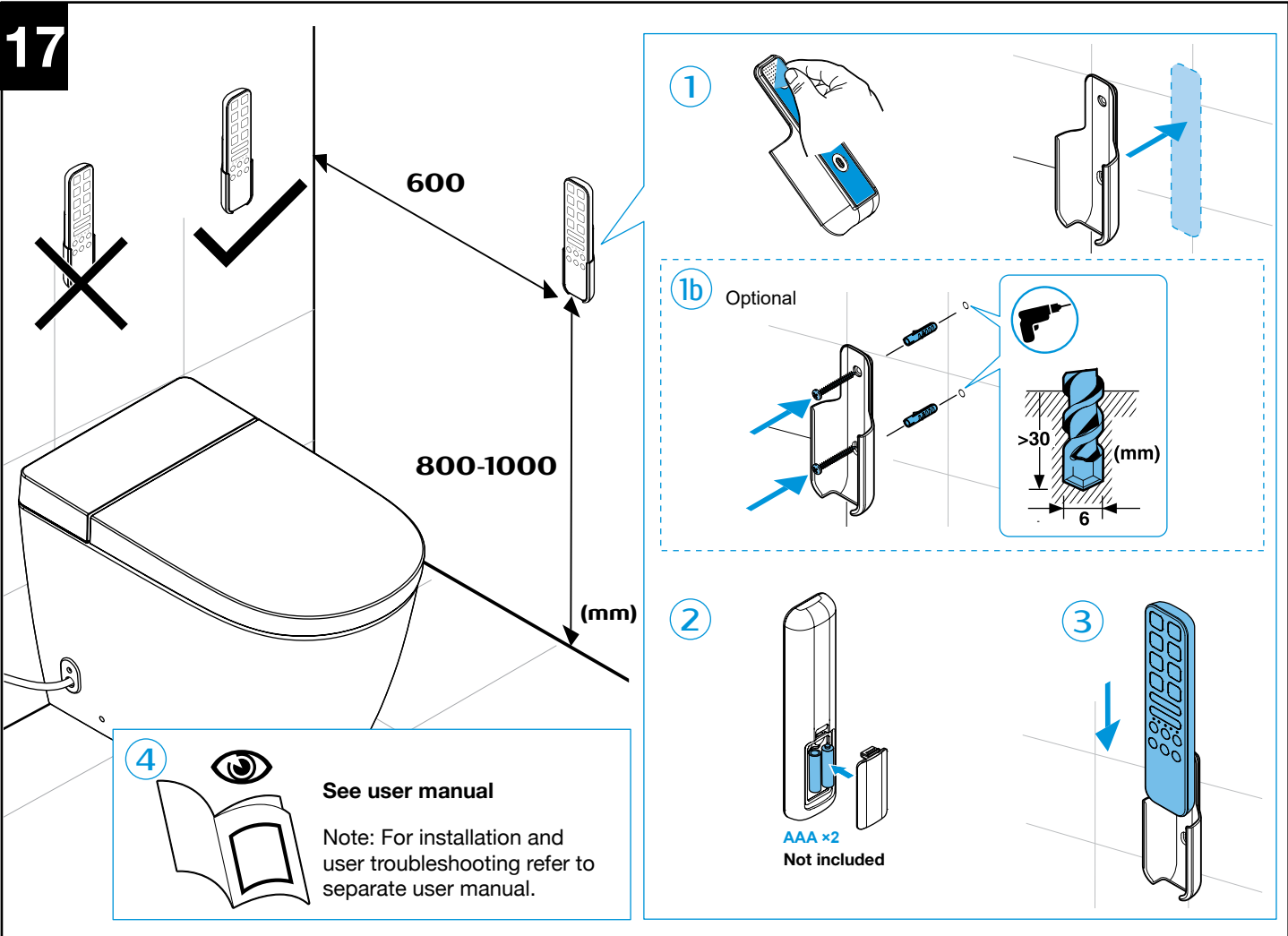

1

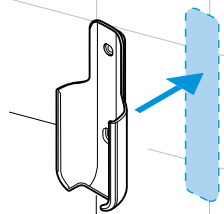

1b

Optional

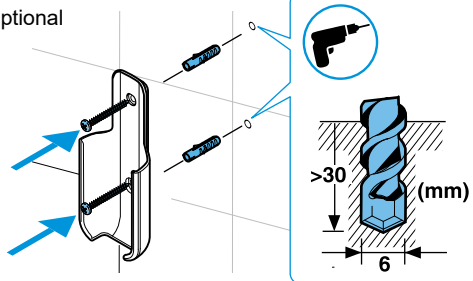

2

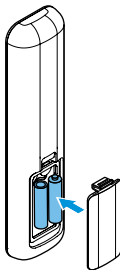

AAA x2
Not included

3

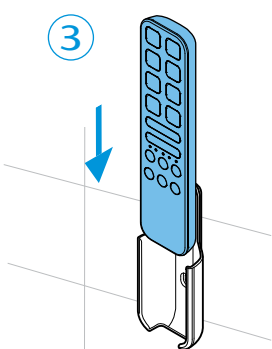



Roca Sanitario, S.A.
Avda. Diagonal, 513
08029 Barcelona
SPAIN
www.roca.com

