

**Roca**

# IN-WASH<sup>®</sup> ONA IN TANK BTW

A80313500R

USER MANUAL

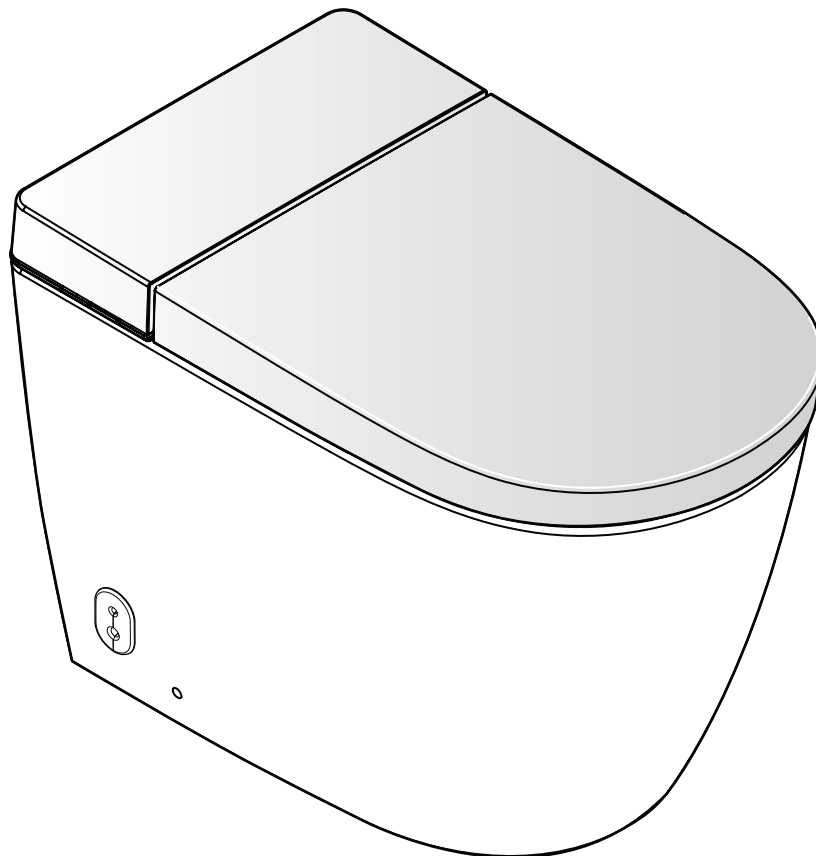

**Fig. 1**

**Floor standing IN-WASH ONA model**

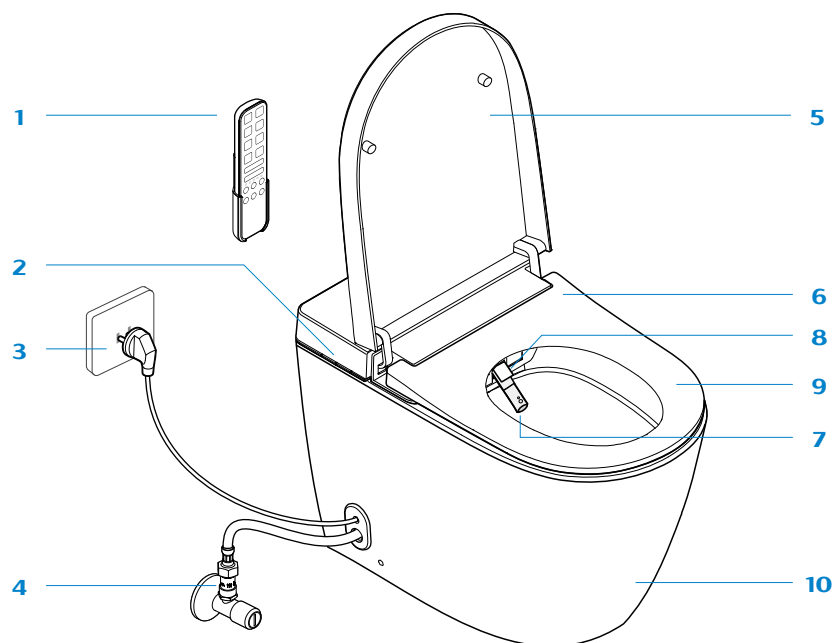

**EN**

- **1** Remote control
- **2** Auxiliary side control
- **3** External socket (optional)
- **4** Shut-off valve & Check valve
- **5** Lid with soft closing
- **6** Seat with soft closing
- **7** Nozzle
- **8** Nozzle and dryer window
- **9** Seat occupied sensor
- **10** Half flush with foot sensor(\*)

**Fig. 2**

**IN-WASH ONA remote control**

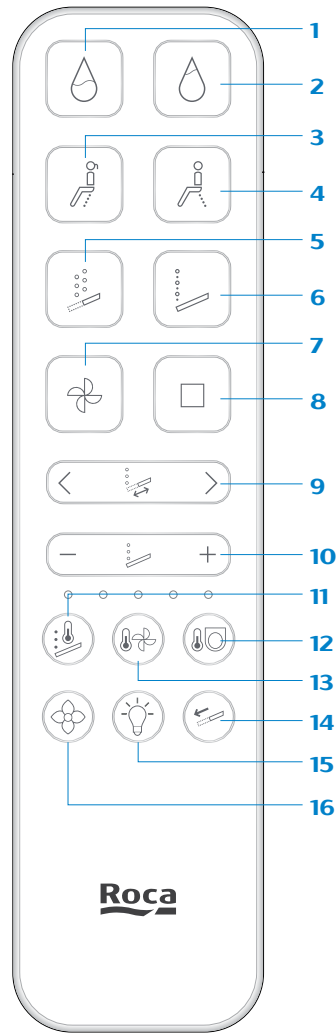

**EN**

- 1 Half flush
- 2 Full flush
- 3 Front wash
- 4 Rear wash
- 5 Oscillating cleaning
- 6 Pulsating cleaning
- 7 Dryer
- 8 Stop
- 9 Nozzle position setting
- 10 Water pressure setting
- 11 Water temperature active function
- 12 Seat temperature setting
- 13 Air pressure setting
- 14 Nozzle extension
- 15 Night light
- 16 Odour extraction



# CONTENTS

<b>1. SAFETY</b>	<b>6</b>
1.1 WARNING - PRECAUTIONS	6
1.1.1 GENERAL WARNINGS	6
1.1.2 INSTALLATION PRECAUTIONS	6
1.1.3 PRECAUTIONS FOR USE	7
1.1.4 MAINTENANCE PRECAUTIONS	7
1.2 ENVIRONMENTAL CONDITIONS	7
<b>2. INTRODUCTION</b>	<b>8</b>
2.1 START-UP	8
2.2 LINKING OF THE REMOTE CONTROLS	8
<b>3. FUNCTIONING</b>	<b>9</b>
3.1 WASH FUNCTIONS	9
3.1.1 REAR WASH	9
3.1.2 FRONT WASH	9
3.1.3 WATER VOLUME ADJUSTMENT	9
3.1.4 NOZZLE POSITION ADJUSTMENT	9
3.1.5 STOP WASH	9
3.2 TEMPERATURE ADJUSTMENT	9
3.2.1 WATER TEMPERATURE ADJUSTMENT	9
3.2.2 SEAT TEMPERATURE ADJUSTMENT	9
3.2.3 DRYER TEMPERATURE ADJUSTMENT	9
3.3 WASH MASSAGING FUNCTIONS	10
3.3.1 OSCILLATING WASH	10
3.3.2 PULSATING WASH	10
3.4 TIME SETTING FOR WASHING AND DRYER FUNCTION	10
3.4.1 REAR WASHING TIME SETTING	10
3.4.2 FRONT WASHING TIME SETTING	10
3.4.3 DRYER TIME SETTING	10
3.5 DEODORIZER	11
3.5.1 DEODORIZER	11
3.5.2 AUTO DEODORIZER	11
3.6 NIGHT LIGHT	11
3.6.1 NIGHT LIGHT	11
3.6.2 NIGHT LIGHT ADJUSTMENT TIME	11
3.7 SILENCE MODE	11
3.8 POWER SAVING	11
3.9 FLUSHING OPERATIONAL INSTRUCTIONS	12
3.9.1 HALF FLUSH	12
3.9.2 FULL FLUSH	12
3.9.3 AUTO FLUSH SETTING	12
3.9.4 TOILET BOWL PRE FLUSH	12
3.9.5 HALF FLUSH WITH FOOT SENSOR	12
3.10 AUXILIARY SIDE CONTROL	13
3.10.1 FULL FLUSH WITH AUXILIARY SIDE CONTROL	13
3.10.2 REAR WASH WITH AUXILIARY SIDE CONTROL	13
3.10.3 DRYER WITH AUXILIARY SIDE CONTROL	13
3.10.4 STOP WITH AUXILIARY SIDE CONTROL	13
3.11 RETURN TO DEFAULT SETTINGS	14
<b>4. CLEANING AND MAINTENANCE</b>	<b>15</b>
4.1 GENERAL CLEANING	15
4.2 NOZZLE AUTO CLEANING	15
4.3 CLEANING OF THE NOZZLE	15
4.4 AUTOMATIC DESCALING PROCESS	16
<b>5. TROUBLESHOOTING</b>	<b>17</b>
<b>6. TECHNICAL FEATURES</b>	<b>19</b>
<b>7. DISPOSAL OF ELECTRIC AND ELECTRONIC PRODUCTS</b>	<b>19</b>

# 1. SAFETY

## 1.1 WARNING - PRECAUTIONS

This device may be used by children 8 years of age and older, people with reduced physical, sensory, or mental abilities, or lack of experience and knowledge, if they have been properly supervised or trained in using the device safely and understand the dangers involved. Children should not play with the device. Cleaning and maintenance must not be carried out by children without supervision.

If the supply cord is damaged, it must be replaced by the manufacturer, its service agent or similarly qualified persons in order to avoid hazard.

When using electric devices, basic safety measures should always be followed; make sure you take into account the following:

### 1.1.1 GENERAL WARNINGS

#### REGARDING THE PACKAGING:

- The packaging of the product is not a toy.
- Do not allow children to play with the plastic bags or with the packaging material as they may present a risk of suffocation or injuries. Keep therefore the material in a safe place or get rid of it following the environmental rules.

#### REGARDING THE ANAL AND PERINEAL CLEANING:

- Do not use the device beyond the time established in each cycle as this may alter your body's natural balance.
- Individuals undergoing medical treatment or therapy in these specific areas should consult with their physician before using this type of product.

#### REGARDING THE SEAT AND COVER:

- Soft-close seat and cover.
- The dampers in the seat and cover provide a slow and silent closure. Do not press any of these two parts with your hand as you might damage the operation of the damper.

### 1.1.2 INSTALLATION PRECAUTIONS

This product should only be installed by qualified staff and with the provided components. Please check the installation manual in order to obtain more information on the electrical and water connections.

Make sure you fulfil the following precautions regarding the hydraulic installation:

- Always connect the product to the domestic cold water mains.
- When installing the water filter, make sure it is tightened adequately and in its correct position.
- The pressure of the water supply of this device should be within the range of 150-500kPa.
- Make sure you fulfil the following precautions regarding the electrical installation:
- Do not handle the socket with wet hands: To remove the plug from the power outlet, do not pull the cable, always pull the plug.
- Always unplug the power cable before handling the product.
- Always use the specified supply voltage (220-240VAC, 50/60 Hz). The product should have an earth connection. It is necessary to install a circuit breaker to the product.
- Do not use a poor or defective electrical connection.
- Place the socket correctly. It should be properly connected to the power outlet, firmly and completely.
- Remove the dust from the power outlet.
- Do not bend or squeeze the connecting tube or the power cable; and keep the cable away from humid, hot or sharp surfaces.
- Do not install the product in wheeled vehicles or boats.
- Ignoring these precautions may cause fire, electric shock, short-circuit or damages to the device.

To confirm that the installation is correct:

- Check that the vitreous china piece is installed according to the provided installation manual.
- Check that the shut-off valve is open.
- Check that the power supply is connected to the product.

When the product is connected to the power supply, the lights blink and a beep may be heard.

The nozzle moves outwards and inwards.

The rotary lights switch off and the product remains in a Stand-by mode, ready to be used.

### 1.1.3 PRECAUTIONS FOR USE

These precautions are important for a safe use. Make sure you follow them and use the product properly.

The product is a WC that has been designed for the cleaning of the anal and perineal areas. It has been designed mainly for private use. Its use is restricted to enclosed spaces. Any other use will not be deemed in accordance with its purpose and Roca will not accept any responsibility for the consequences that might arise from an improper use.

Should there be an operational failure, please check the troubleshooting chart.

To lean back when you are sitting on the product will facilitate the adjustment of the nozzle and will reduce possible splashing.

Do not urinate or splash water or cleaning agents on the main body or the mains plug.

This may cause a fire, electric shock, heat or a short-circuit and you may cause stains or a malfunction.

Do not ever obstruct any opening in the product, nor should you drop or insert any objects in them. Keep the air inlet free of lint.

Do not place any open flames, candles, cigarretes or similar items over the product and do not drop flammable items or cigarretes near or inside the product.

Do not step on the product.

Avoid forcing the seat or the cover.

Please do not bend, pull or twist the power cable, nor should you place heavy objects on it.

Do not leave towels or tissues on the heated seat. This could affect its thermal behaviour.

If there is a water leak, always close the shut-off valve.

Do not use a booster seat for children or adults if you are going to use the product.

To avoid dropping the remote control, place it on its base when you are not using it.

### 1.1.4 MAINTENANCE PRECAUTIONS

Stop the product if you are not going to use it for a long period of time.

Do not disassemble or repair the product; please contact Technical Assistance in case of breakdown. Any repairs should be carried out by authorised staff, using original spare parts and accessories.

When you use cleaning agents to clean the WC, clean it and remove it in 3 minutes, leaving the seat and cover always open.

Clean any remains of detergent from the WC bowl. (If the vapour from a WC cleanser enters the main unit, it may cause a malfunction).

If the supply cord is damaged, it must be replaced by the manufacturer, its service agent or similarly qualified persons in order to avoid a hazard.

## 1.2 ENVIRONMENTAL CONDITIONS

The room temperature should not be below 4°C or over 40°C.

When the room temperature drops below 4°C, avoid damages due to freezing; frozen water pipes could break the product and the pipes, resulting in a water leak; regulate the room temperature to prevent the pipes and hoses from freezing during the cold months.

## 2. INTRODUCTION

### 2.1 START-UP

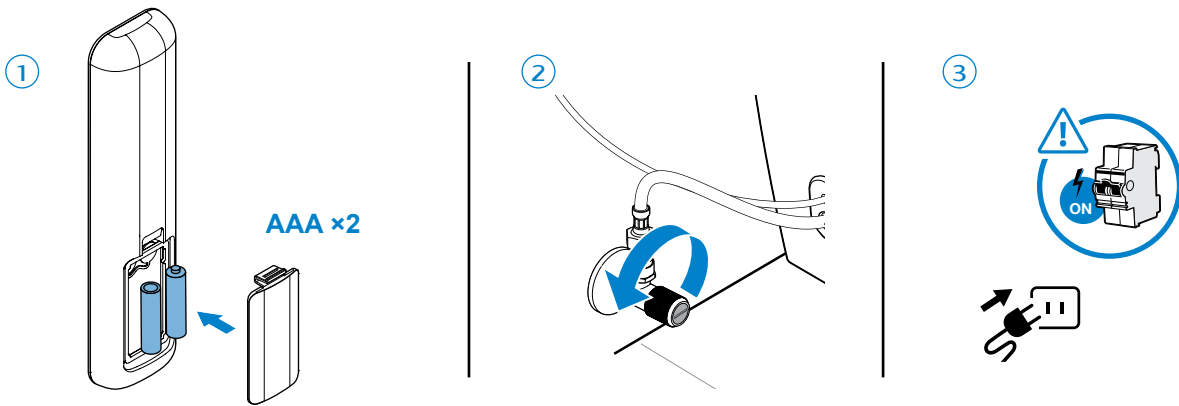

To start up the product follow the steps described below:

1. Please the batteries inside the remote control.
2. Open water supply valve.
3. Activate the power to supply the IN-WASH ONA.

### 2.2 LINKING OF THE REMOTE CONTROLS

When the toilet is powered on, you will hear a beep from the toilet. Simultaneously for 3 seconds press the Water Volume + and - button at the same time. You will hear a beep from the toilet again. There will be 5 white LED lights on the remote control. After flashing, the LED light will turn white, indicating successful pairing.

Do not disconnect the appliance during this process.

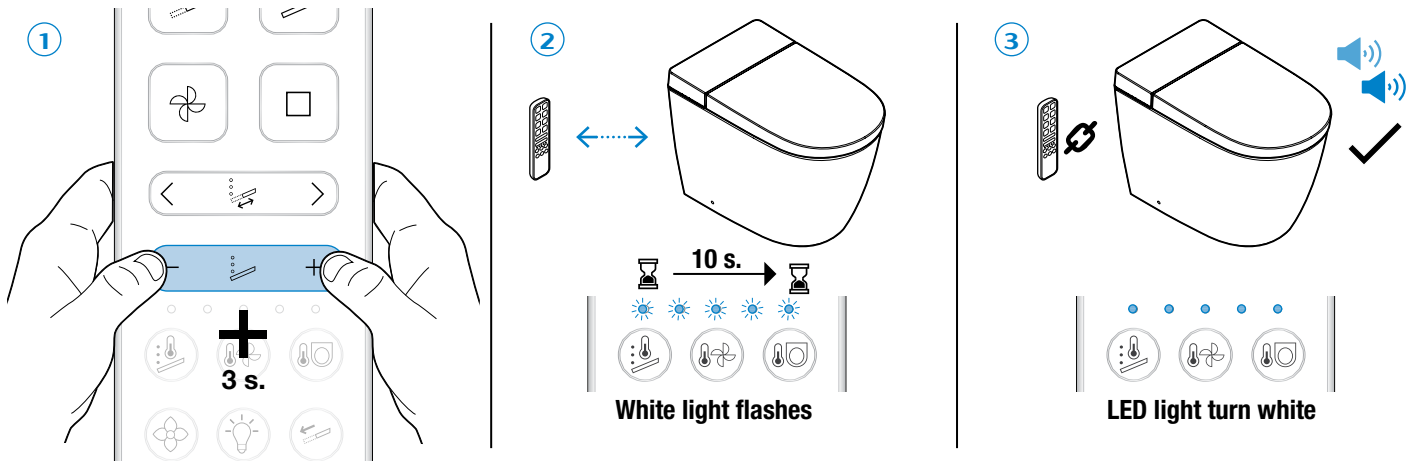

**!** Once this process has been carried out, all previously modified values will be deleted and the IN-WASH ONA will have its factory default settings restored. Please complete the setup with in 1 minute, if the process can't be finished in the 1 minute, please re-operate it.

## 3. FUNCTIONING

### 3.1 WASH FUNCTIONS

#### 3.1.1 REAR WASH

Press rear wash button to activate.

The wash function will stop automatically after 5 minutes.

#### 3.1.2 FRONT WASH

Press the front wash button to activate.

The wash function will stop automatically after 5 minutes.

#### 3.1.3 WATER VOLUME ADJUSTMENT

While you are using the rear wash or front wash functions, press **+** to increase or **-** to decrease the set water volume while the washing function is active.

There are 5 levels available.

#### 3.1.4 NOZZLE POSITION ADJUSTMENT

While you are using the rear wash or front wash functions, press the arrow buttons to adjust the nozzle extension length.

There are 5 levels available.

#### 3.1.5 STOP WASH

Press the stop button to end the washing function.

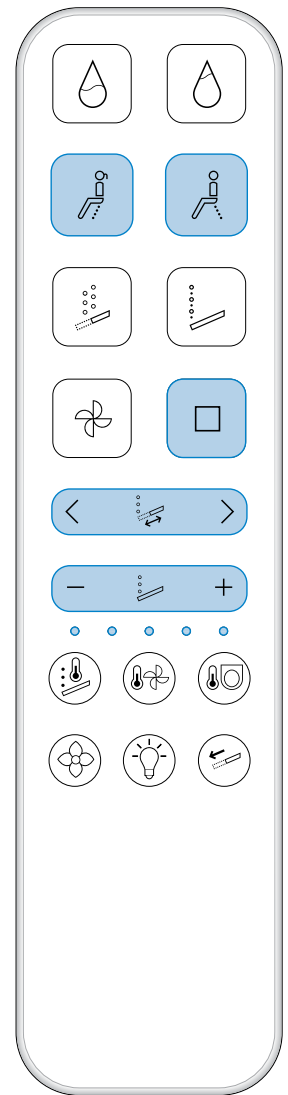

### 3.2 TEMPERATURE ADJUSTMENT

#### 3.2.1 WATER TEMPERATURE ADJUSTMENT

While using the rear wash or front wash functions, press water temperature button.

Pressing the water temperature button repeatedly will adjust the water temperature to one of 5 settings.

You can adjust the temperature while washing using the wash function on the remote.

#### 3.2.2 SEAT TEMPERATURE ADJUSTMENT

Pressing the seat temperature button repeatedly will adjust the seat temperature to one of 5 settings.

#### 3.2.3 DRYER TEMPERATURE ADJUSTMENT

Press the dryer button to activate, and press the stop button to stop drying.

Press the dryer temperature button to adjust the dryer temperature to one of 5 settings.

You can adjust the temperature while drying by pressing the button on the remote.

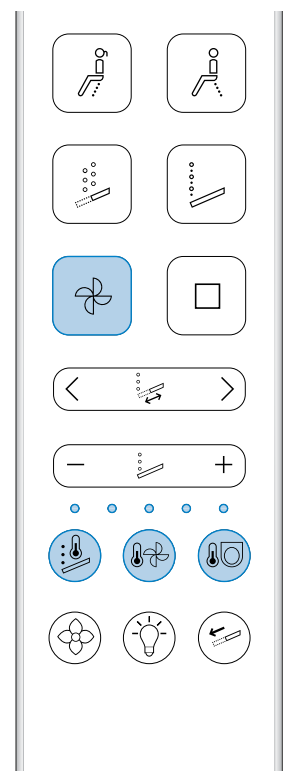

Do not insert fingers or any objects into the fan.

The dryer function will stop automatically in 5 minutes. Please press the button again to resume the function.

## 3.3 WASH MASSAGING FUNCTIONS

### 3.3.1 OSCILLATING WASH

When the oscillating wash function is activated, the nozzle moves back and forth to increase the washing range.

While you are using the rear wash or front wash functions, press oscillating button to activate or deactivate oscillating washing mode.

### 3.3.2 PULSATING WASH

With activating the pulsating washing function, the water pressure cycles between strong and soft water pressure in a certain rhythm for washing.

While you are using the rear wash or front wash functions, press pulsating button to activate or deactivate pulsating washing mode.

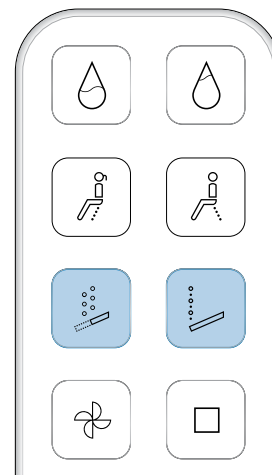

## 3.4 TIME SETTING FOR WASHING AND DRYER FUNCTION

Washing/dryer function duration may be adjusted in order to automatically stop.

### 3.4.1 REAR WASHING TIME SETTING

Press the rear wash button for 3 seconds to adjust the front washing duration.

Press water pressure + or - button for rear washing duration adjustment.

There's 5 setting levels: 30-60-90-120-150s.

### 3.4.2 FRONT WASHING TIME SETTING

Press the front wash button for 3 seconds to adjust the front washing duration.

Press water pressure + or - button for rear washing duration adjustment.

There's 5 setting levels: 30-60-90-120-150s.

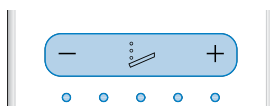

30-60-90-120-150s

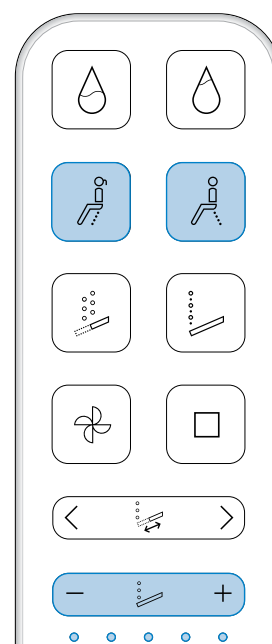

 Note: By setting off, front or rear washing function will stop automatically after 5 min. Please press the rear or front wash button again to resume the function.

### 3.4.3 DRYER TIME SETTING

Press dryer button for 3 consecutive seconds to adjust dryer duration mode.

Press water pressure + or - button for dryer duration adjustment.

There's 5 setting levels: 30-60-90-120-150s.

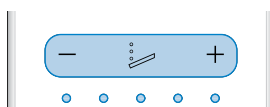

30-60-90-120-150s

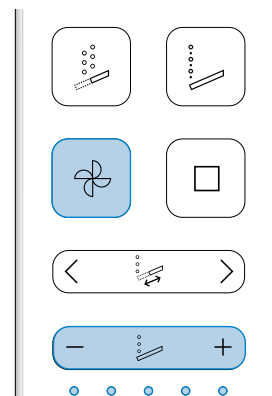

 Note: When turned off, the dryer function will stop automatically after 5 minutes. Please press the dryer button again to resume the function.

## 3.5 DEODORIZER

### 3.5.1 DEODORIZER

Use activated carbon filter to remove the odor. You may manually activate deodorizer by pressing deodorizer button or set auto deodorizer.

Press deodorizer button to activate and deactivate deodorizer function manually.

### 3.5.2 AUTO DEODORIZER

The auto deodorizer will automatically activate once the toilet seat is occupied and will automatically switch off when the toilet seat is not occupied for more than 1 minute.

Press the deodorizer button for 3 seconds to switch between auto deodorizer on and off..

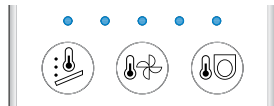

Auto deodorizer ON

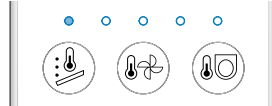

Auto deodorizer OFF

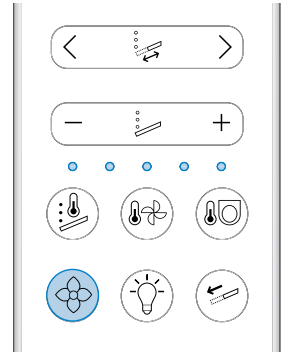

## 3.6 NIGHT LIGHT

### 3.6.1 NIGHT LIGHT

Press the night light button to activate it. Press the same button repeatedly to adjust the night light settings.

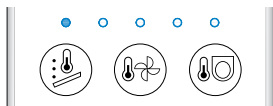

Night light ON

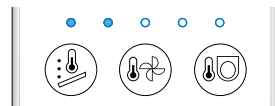

Side panel light ON

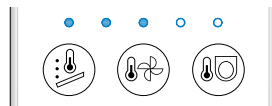

Night light & Side panel light ON

### 3.6.2 NIGHT LIGHT ADJUSTMENT TIME

Press the night light button for 3 seconds to enter adjustment mode, then press the water pressure + or - button to adjust the time: 4-8-12-16-24 hr-Off.

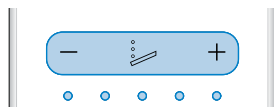

4-8-12-16-24hr

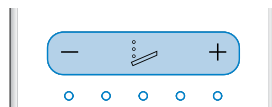

Night light OFF

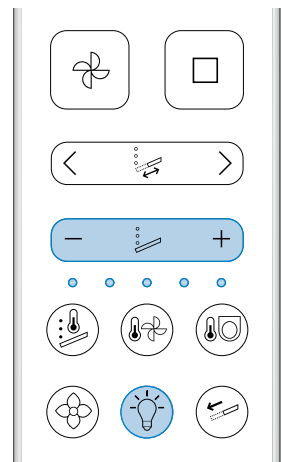

## 3.7 SILENCE MODE

The IN-WASH ONA offers the option of silencing the sound it emits when activating the functions and settings.

To silence it, press dryer temperature button for consecutive 3 sec to activate silent mode. To return to the previous state, repeat the action.

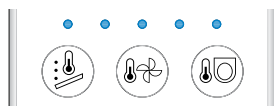

Silence ON

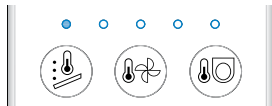

Silence OFF

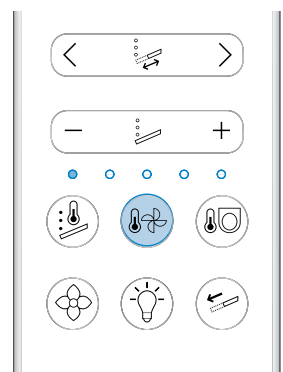

## 3.8 POWER SAVING

Main power consumption will turn off automatically when power saving is set. The main power will resume once the toilet seat is occupied again by user.

Press seat temp button for 3 consecutive seconds to activate or deactivate auto power saving. Smart toilet stores data about using time and automatically set power saving.

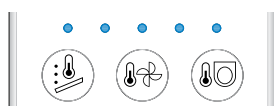

Power saving ON

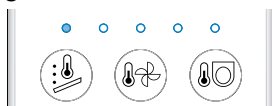

Power saving OFF

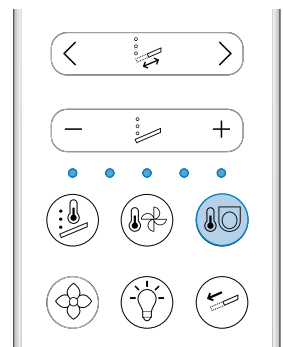

### 3.9 FLUSHING OPERATIONAL INSTRUCTIONS

#### 3.9.1 HALF FLUSH

Press the half flush button to activate.

#### 3.9.2 FULL FLUSH

Press the full flush button to activate.

#### 3.9.3 AUTO FLUSH SETTING

Press full flush button for consecutive 3 sec activate seat sensor auto flush.

Auto flush function will be activated when user sits on seat sensor position of IW-WASH ONA.

Auto flush will activate 7 seconds after no user is detected.

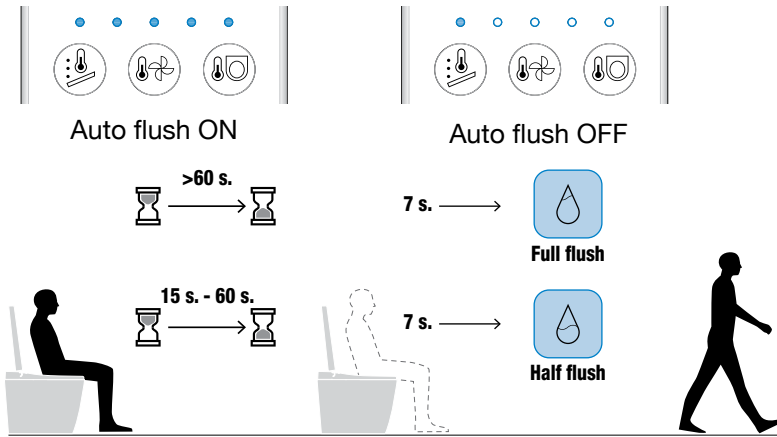

#### 3.9.4 TOILET BOWL PRE FLUSH

Press the half flush button consecutive 3 seconds to activate or deactivate pre-flush.

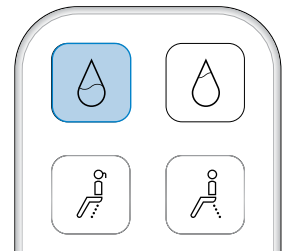
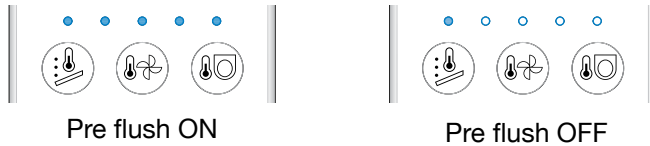

#### 3.9.5 HALF FLUSH WITH FOOT SENSOR

Use foot sensor to activate half flush flushing.

Press the half flush and full flush buttons simultaneously to activate or deactivate the foot sensor flush.

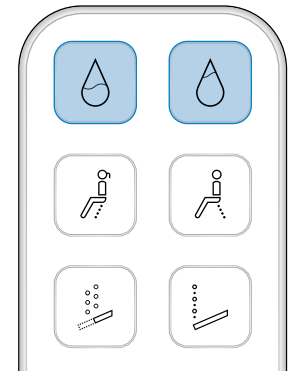
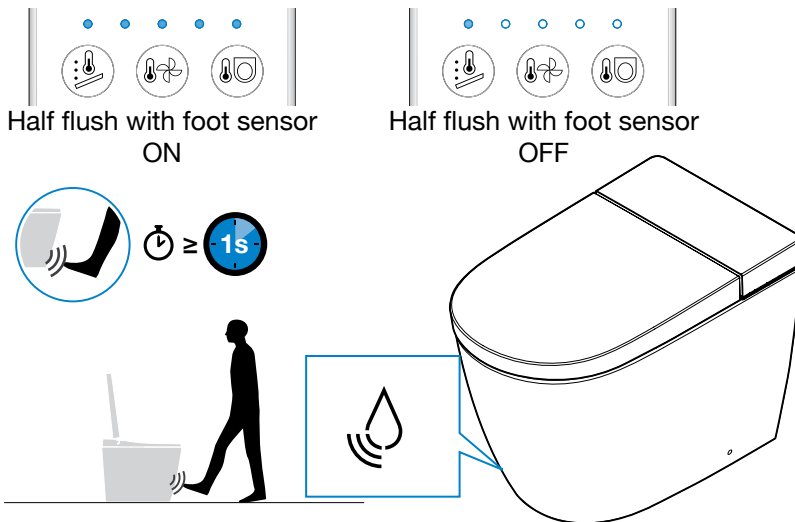

⚠ Please do not cover the sensing area with debris.  
 When you use a mop and other tools to clean the floor at the bottom of the toilet or when a pet passes through the sensing area at the bottom of the toilet, automatic flushing will be triggered.  
 When the foot sensor is set to ON, do not place anything that can be sensed in the sensing area.

## 3.10 AUXILIARY SIDE CONTROL

The auxiliary side control can be used to monitor the main product functions: Rear wash and dryer.

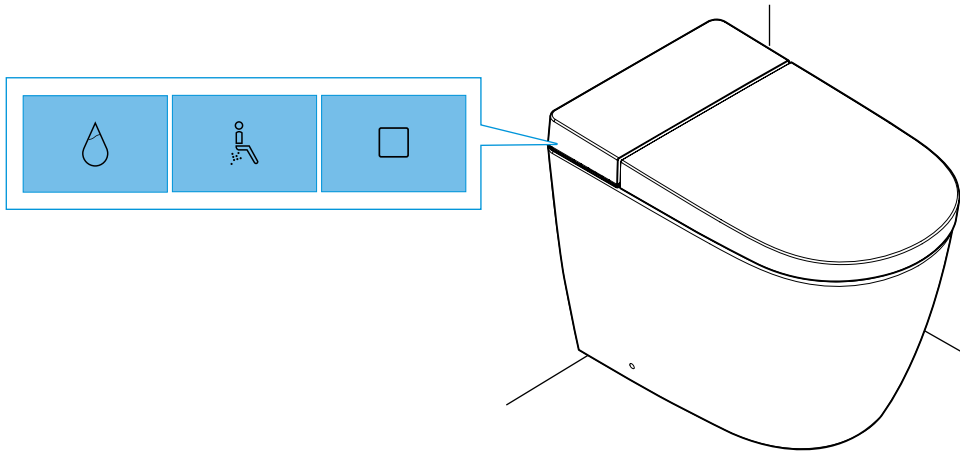

### 3.10.1 FULL FLUSH WITH AUXILIARY SIDE CONTROL



In case of power supply failure, or in case that the remote control runs out of batteries, it is possible to make a full flush of the deposit, using the button on the auxiliary side control.

### 3.10.2 REAR WASH WITH AUXILIARY SIDE CONTROL



Press the rear wash button to activate the function. To stop this function, press the stop button on the auxiliary side control or on the remote control.

The washing stops after 5 minutes if no other button is pressed.

Press button for 3 seconds the water temperature can be adjusted to Off-1-2-3-4-5 settings.

### 3.10.3 DRYER WITH AUXILIARY SIDE CONTROL

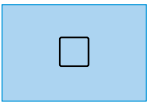

After the rear wash function stops, press the stop button to activate the dryer function.

Press button for 3 seconds the dryer temperature can be adjusted to Off-1-2-3-4-5 settings.

### 3.10.4 STOP WITH AUXILIARY SIDE CONTROL

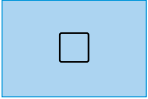

It stops any activated function.

## 3.11 RETURN TO DEFAULT SETTINGS

To return to the factory settings carry out the remote control. Press and hold the stop button for 10 seconds. After a beep is heard, the settings will return to default.

### Factory default settings:

Seat temperature	Off
Dryer temperature	Off
Washing water temperature	Off
Rear washing water volume	Level 3
Front washing water volume	Level 3
Rear and front washing nozzle position	Level 3
Auto odour extraction	Off
Night light	Off
Power saving	Off
Auto flushing	On
Pre flush	Off
Foot sensor flush	On
Silence mode	Off

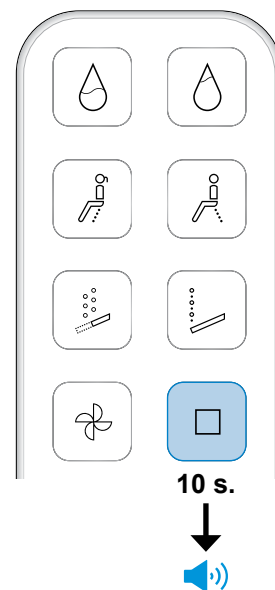

When the return to the default value is completed, the setting values of the host and the remote control will return to the default value.

When reset of the product the setting will return to the default settings.

## 4. CLEANING AND MAINTENANCE

### 4.1 GENERAL CLEANING

#### CLEANING OF THE REMOTE CONTROL

Clean the remote with a damp soft cloth.

If the remote control is very dirty, you may use diluted neutral detergent.

Do not remove the cover of the batteries during its cleaning.

#### CLEANING OF THE DEVICE

Clean the outside of the device with care using a soft and damp cloth or a sponge.

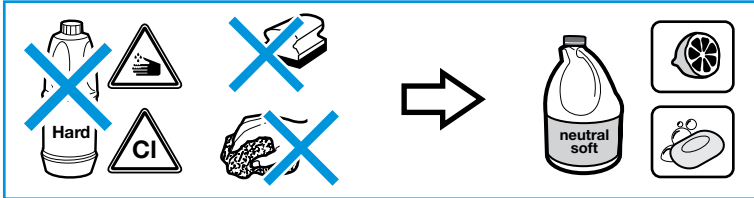

#### Important:

Do not use aggressive cleaning products. Only use neutral cleaners.

Do not pull or push the nozzle manually.

While cleaning the WC leave the cover open for a few hours so that gases do not enter the IN-WASH ONA.

Do not spray the water or the air outlets with water or cleaning agents that may enter inside the IN-WASH ONA.

### 4.2 NOZZLE AUTO CLEAN

Press nozzle extension button for consecutive 3 sec to activate the nozzle cleaning. It will automatically oscillate forward and backward for 1 minute. To deactivate this function, please press stop button.

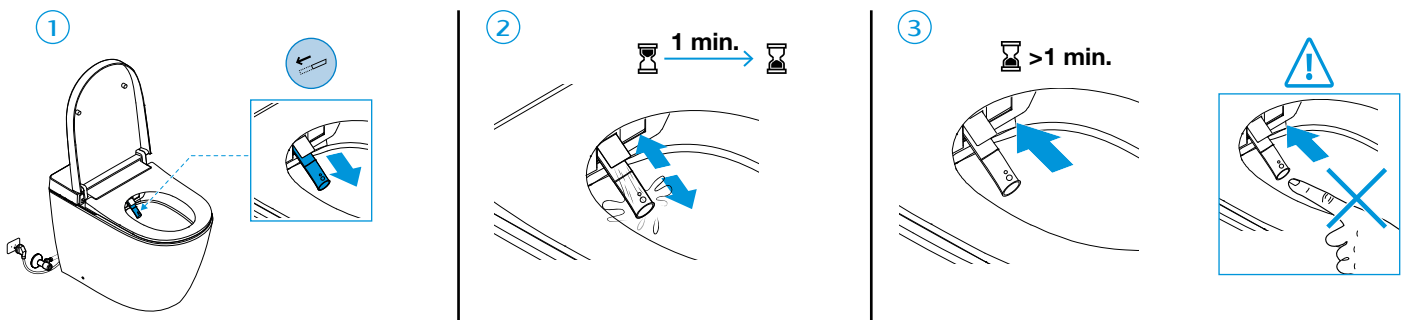

### 4.3 CLEANING OF THE NOZZLE

Press nozzle extension button, and nozzle will be extended for 1 minute and retract automatically.

To stop this function in advance, press stop button.

Please use a brush and water to gently remove the clog.

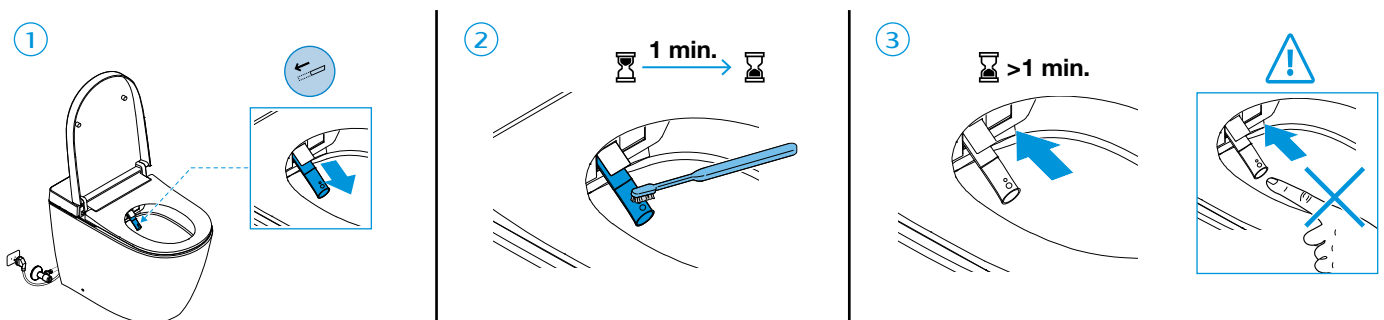

Do not use aggressive product to clean. Only use neutral product for cleaning.  
Do not pull or push the nozzle manually.  
Do not remove the nozzle by hand.

## 4.4 AUTOMATIC DESCALING PROCESS

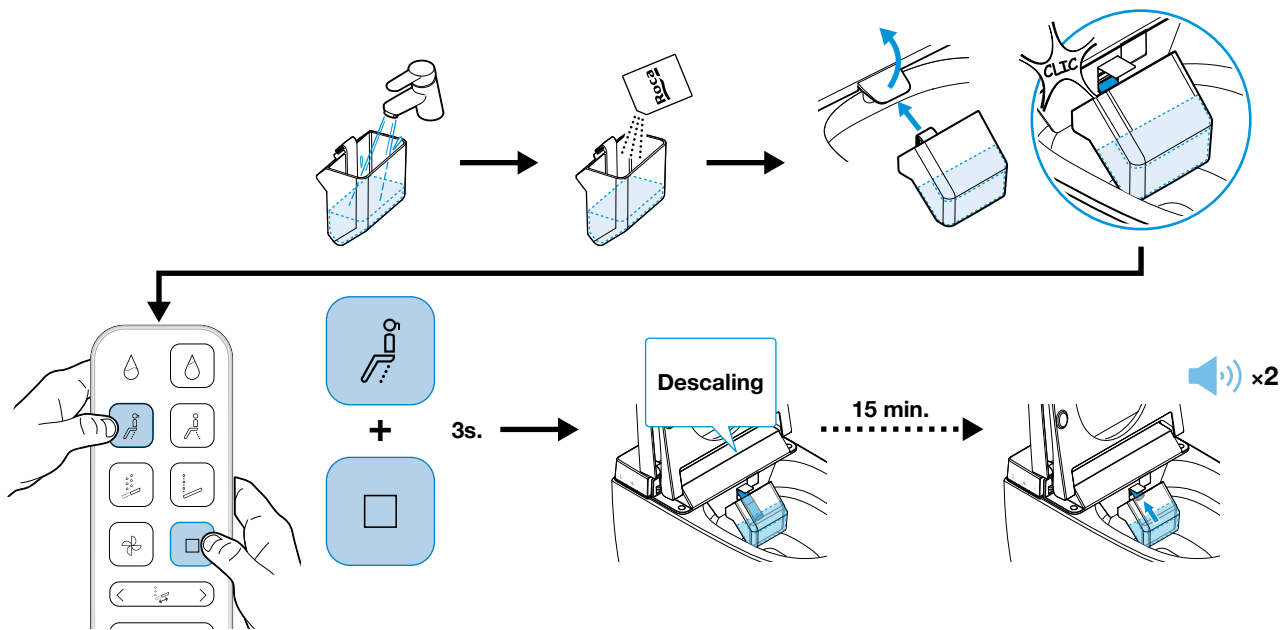

Do not sit on the toilet seat. This deactivates the seat sensor.

1. Assemble the beaker parts.
2. Place the beaker in vertical position and fill it up to the mark inside.
3. Pour the contents of the descaling sachet (ref. A805072002) into the beaker and mix gently.
4. Manually lift the nozzle door and introduce the beaker neck inside. Make sure that it securely rests against the porcelain.
5. Press the front wash button and stop button simultaneously to consecutive 3 seconds to activate descaling mode. (the interval between each time shall not exceed 2 seconds, the night light and button will flash once, indicating that it has entered the descaling mode).
6. After the nozzle discharges water from the toilet tank, the nozzle automatically reaches into the descaling box and draws the descaling liquid from the descaling box.
7. During the descaling process, the product will absorb, let stand and then discharge water. This action will cycle 15 times each (front cleaning/rear cleaning nozzle).
8. After completing the descaling process, the nozzle will automatically reset and start self-washing to drain the descaling fluid in the water tank.
9. After draining the descaling fluid, the water tank refills with water, and a beep sounds at the same time to indicate the completion of the descaling process. The entire process takes about 15 minutes. It is recommended to descale the product at least once a year, or if it is detected that the flow of washing water has been reduced considerably. In geographical areas with very hard water, a higher frequency may be recommended.

## 5. TROUBLESHOOTING

	PROBLEM	POSSIBLE CAUSE	SOLUTION
1	Not working.	The device is turned off	Connect the product.
		Connect the product to the power supply.	Connect the device to the mains.
2	The product does not respond when pressing the remote control, and the remote control does not switch on.	The batteries of the remote control are dead.	Replace the batteries.
		The batteries of the remote control are not properly placed.	Verify that the batteries are placed in the correct position.
3	After a flush, water still flows from the rim.	The filling solenoid does not close properly	Close the stopcock and call Technical Service*. Do not perform any flush.
4	The washing pressure is low, or only a small amount of water comes out. The lights blink once and a beep sounds.	Water pressure is low.	Adjust the water pressure.
		The nozzle tip is calcified.	Descale the tip of the nozzle and reset the product.
5	The washing function does not work or fails to spray. The lights blink twice and beep twice.	The user is not properly seated.	Adjust the nozzle position.
6	The washing function does not work or fails to spray. The lights blink 3 times and beep x3 sound.	Device sensor system error.	Sit down again and operate the wash function.
			*
7	Washing water temperature is too high. The lights blink 4 times and beep x4 sound.	Water pressure is low	Adjust water pressure.
		Water temperature is out of specification.	Wait between 5-10 minutes in order product self recovery normal temperature.
		Device heating system error.	Shut down the device and call Technical Service.*
8	Seat heater temperature is too high. The lights blink 5 times and beep 5 times.	Seat temperature is out of specification. The seat heater temperature is above 50°C or below 20°C.	Turn off seat heating function.
			Wait 5–10 minutes for the product to return to a normal temperature.
9	Dryer temperature abnormal. The lights blink 6 times and beep 6 times.	Dryer temperature out of specification.	Wait 5–10 minutes for the product to return to a normal temperature.
		The dryer temperature is above 60°C or below –20°C.	Shut down the device and call Technical Service.*
10	The device shuts off while it is in use in wash mode.	The wash time has exceeded the set limit. Reactivate the cleaning function.	Repeat cleaning function.
		There is a power failure. Check the power plug, or unplug it and plug it in again.	Check the power cord, or unplug and replug it. Then reset the product.
11	The device shuts off while it is in use in dry mode.	The dry time has exceeded the set limit.	Reactivate the drying function.

	PROBLEM	POSSIBLE CAUSE	SOLUTION
12	The nozzle does not function properly.	The nozzle head is dirty.	Clean the nozzle head.
		Debris blocking check valve or mesh strainer in hose or there is a general supply failure.	Check the water supply from the mains, after clearing any debris, and reset the product.
13	The nozzle does not move back.	The power supply has been cut.	Restore the main power. The nozzle will return automatically.
		The nozzle motor has lost its position.	Reset the product.
		Internal components or mechanisms are malfunctioning.	*
14	The device moves when sitting down.	The rear bracket of the product is not tight enough.	Tighten the screws.
15	Water comes out through the nozzle door and the function is not activated.	Excessive water level in the internal tank due to a failure of an internal component of the equipment.	*
* Should the problem persist, please call the Technical Assistance.			

## 6. TECHNICAL FEATURES

<b>Model</b>		<b>A80313500R</b>
Supply voltage		220-240V~, 50/60Hz
Max. power input		1700 W (*)
<b>Front and rear cleaning</b>	Tap water pressure (connect to cold water)	0,09~0,8 MPa (0,9~8bar)
	Rear spray volume	0.3-0.8 l/min
	Front spray volume	0.3-0.8 l/min
	Maximum heater capacity	1650 W
	Heating system	Instant water heating
	Water temperature	Off / Approx. 33°C ~ 39°C (5 Levels)
	Safety device	Water temperature sensor, Grounding protection, Self-setting temperature controller, Non-self-setting temperature controller, Thermal fuse
<b>Dryer</b>	Warm dryer temperature	Room temperature / Approx. 35~55°C (5 Levels)
	Maximum heater capacity	290 W
	Air volume	6-11 m/s
	Safety device	Temperature sensor, Thermal fuse
<b>Seat</b>	Heated seat surface temperature	Off / Approx. 35°C~39°C (5 Levels)
	Heater capacity	50W (Max.)
	Safety device	Temperature sensor, Seat occupied sensor, Temperature controller, Thermal fuse
Deodorizer		Active carbon
Remote control		DC 1.5 V AAA Alkaline battery
Supply water temperature		10~30°C
Ambient temperature		4~40°C
Classification of waterproof		IPX4
Length of power cord		PCB END:0.18m, PLUG END:1.5m
Product size		L:665 x W:395 x H:465mm
Product net weight		~37 kg (±10%kg)
Product gross weight		~40 kg (±10%kg)

\* Water inlet temperature (15±1°C)

## 7. DISPOSAL OF ELECTRIC AND ELECTRONIC PRODUCTS

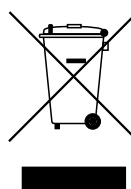

NOTE: This symbol and recycling system is only applicable in the European Union. It does NOT apply to the rest of the world.

At ROCA we are committed to protecting the environment. Please help us by discarding this product at the end of its life-cycle in a responsible manner, to prevent that certain substances contained in electrical or electronic equipment may cause harm to human health and the environment.

The crossed-out wheeled bin symbol, shown above and on the product, means that it should not be discarded with other household waste. At the end of the product's life-cycle, it must be delivered to the corresponding collection facilities enabled by the authorities in your country or to the supplier from which you purchase a product of equivalent type or that fulfills the same functions as the previous equipment. This last option may not be available in some countries, so please check with the authorities in your country about the collection systems available and the collection facility closest to your home.

This way, you can cooperate with the protection of the environment through the reuse and recycling of waste electrical and electronic equipment. On the contrary, administrative responsibilities can be derived for you in case of non-compliance with the rules for the delivery of the waste of this product.

Batteries shall be previously removed and discarded separately in suitable recycling containers.



**Roca Sanitario, S.A.**  
Avda. Diagonal, 513  
08029 Barcelona  
SPAIN  
[www.roca.com](http://www.roca.com)

**933** | LÍNEA DE ATENCIÓN  
**661** | AL CONSUMIDOR  
**266** | ESPAÑA   
SERVICIO TÉCNICO   
ESPAÑA

