



WOLFEN

INSTALLATION MANUAL

9507171 Wolfen Back Rest with Fixed Arms





WOLFEN™

Delivering unrivalled quality

Designed for absolute performance, Wolfen's back rest sets new standards in quality and durability. With 316 grade stainless steel coach screw fixings, the back rest comes with pre-assembled 304 grade stainless steel arms and white back rest made from UV stabilised HDPE.

CONTENTS

Intro	02
Technical Information	03
Installation Instructions	04
Warranty	06

TECHNICAL INFORMATION

Product Code	9507171
Colour	Stainless Steel Arms White Back Rest
Finish	Brushed Arms
Material	304 Grade Stainless Steel Arms UV stabilised HDPE Back Rest 316 Grade Stainless Steel Coach Screws

Wolfen Back Rest with Fixed Arms

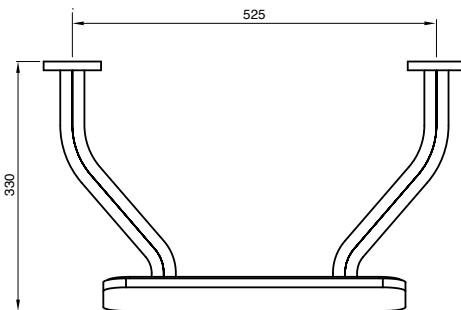
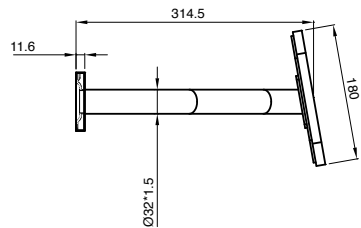
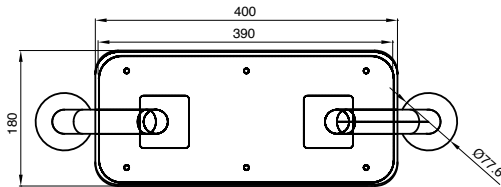

INSTALLATION INSTRUCTIONS

Important Note

The Wolfen back rest should be properly assembled, installed and cared for. Failure to follow the below instructions may result in serious injury.

The back rest bar meets AS 1428.1-2009 and is manufactured from high quality stainless steel with a HDPE back rest. It has been tested to a loading of 1100N. Proper care must be taken to install the grab bar to an appropriate load bearing base, using appropriate fixing bolts.

Installation Instructions:

1. Confirm the contents of the box.
The box should contain 1 back rest grab bar and 6 screws.

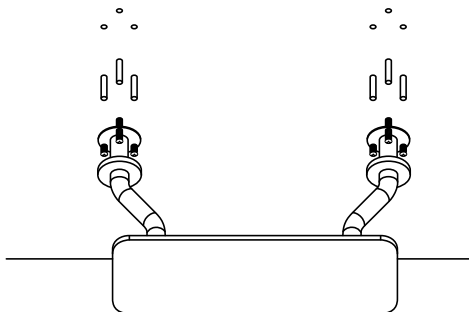

IMPORTANT INSTALLATION NOTE:

Where there is an inwall cistern installed, take care to ensure that no screws are drilled into the concealed cistern.

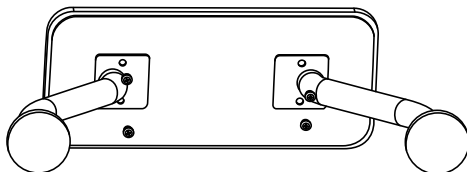

2. Assemble the two legs to the stainless panel.

Ensure that the wall the back rest is to be mounted to contains sufficient timber to provide proper structural support.

- Using the mounting flange plates as a template, mark the centre of the screw hole locations and drill in the holes.

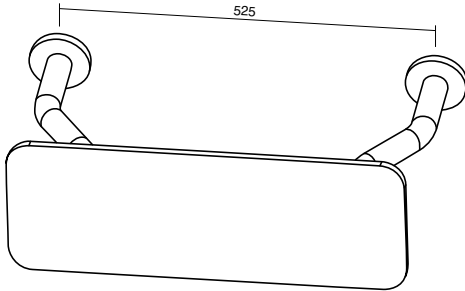

- Install the back rest with the screws provided. Inspect each screw to ensure it is tight.
- Twist the flange onto the mounting flange plates.

Maintenance

Clean product with mild soap and water.

REECE PRODUCT QUALITY GUARANTEE



You have purchased a quality product from Reece Australia Pty Ltd ABN 84 004 097 090 ("Reece"). This product is covered by a 5 year replacement product warranty and a 12 month warranty over spare parts and labour.

5 YEAR WARRANTY

This warranty covers faults in the product construction, material and assembly. Products which are within 5 years from the date of purchase, found upon inspection by an authorised Reece representative, to be defective in construction, material or assembly, will be repaired or exchanged with an equivalent product free of charge. Replaced items become Reece's property.

All replacement products will be available for collection without charge to the customer at the nearest Reece branch to the customer's location, or elsewhere as agreed between the customer and Reece.

Labour and Spare Parts

The labour for the replacement of products and spare parts to which this warranty applies will be supplied by Reece or relevant supplier using licensed plumbers engaged by Reece or relevant supplier within 1 year from the date of purchase. Spare parts other than those listed in the Manufacturer's Provisions above, which are within 1 year from the date of purchase found upon inspection by an authorised Reece representative to be defective in construction, material or assembly, will be replaced free of charge.

Warranty Conditions

This warranty will apply only under all of the following conditions:

- The item has been installed by a licensed plumber
- Failure is due to a fault in the manufacture of the product
- Proof of purchase (including the date of purchase) is provided
- The installation of the product is in accordance with the instructions provided

This warranty does not cover products purchased as an ex-display without being fully checked and tested for sale by the manufacturer.

This warranty does not include faults caused by:

- Unsuitable or improper use
- Incorrect installation or installation not in accordance with the instructions provided
- Installation or part installation by the purchaser or any person other than a LICENSED PLUMBER
- Normal wear and tear
- Inadequate or complete lack of maintenance
- Chemical, electrochemical or electrical influences
- Harsh detergents or abrasive cleaners used on product finishes

EXCLUSIONS

To the fullest extent permitted by law, Reece excludes all liability for damage or injury to any person, damage to any property, and any indirect consequential or other loss or damage.

CLAIM PROCEDURE

For all warranty queries customers are to contact the branch where the product was purchased. These details can be found on your purchase invoice.

Our goods come with guarantees that cannot be excluded under the Australian Consumer Law. You are entitled to a replacement or refund for a major failure and for compensation for any other reasonably foreseeable loss or damage. You are also entitled to have the goods repaired or replaced if the goods fail to be of acceptable quality and the failure does not amount to a major failure.

Don't risk it, use a licensed plumber.™

IF AFTER CHECKING THE
INSTALLATION INSTRUCTIONS
AND IMPORTANT INFORMATION,
THE PROBLEM HAS NOT BEEN
IDENTIFIED, PLEASE CONTACT
YOUR LOCAL REECE STORE ON:

1800 032 566



WOLFEN™

reece.com.au/wolfen