

## BWT Multistage UV System - UV20

From Europe's largest water treatment company BWT, the UV20 Multistage UV System is the solution for a continuous supply of clean and safe water. Designed to handle flow rates for entire houses and light commercial applications the Multistage UV20 reduces sediment, particulate matter, bad taste & odours and kills 99.99% of bacteria, giardia cysts and cryptosporidium. Ultraviolet disinfection is a natural process which is chemical free and eco friendly. A UV controller monitors key parameters to help manage and maintain the UV20.

**Lockable top cover** to protect Controller and Lamp Replacement cap

**Stage 1** Sediment filtration to reduce sediment and particulate matter

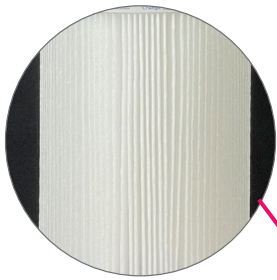

**Stage 2** Activated carbon cartridge to reduce bad taste & odours and organic matter

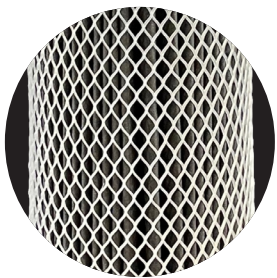

**BWT Controller** monitors lamp life with a countdown timer. A handy 2 stage alarm provides a call to action



**Stage 3** Ultraviolet lamp with a quartz glass sleeve all contained within a stainless steel pressure vessel

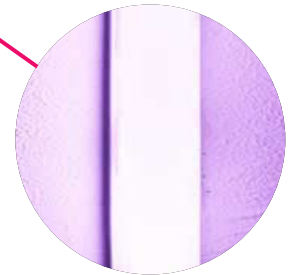

### Features & Benefits

- Multistage UV Filter System turns your mains or tank water into clean, safe potable water
- Supplied on manifold bracket and lockable cover - all assembled
- Quality design and materials of construction for performance and longevity
- WaterMark product - assurance of quality and performance

Specifications	
Model:	BWT UV20
Connection:	1" bspf (inlet) 1" bspm (outlet)
Water Pressure:	300 kPa min - 860 kPa max
Water Temperature:	4 deg C - 40 deg C (Protect from freezing)
Flow Rate:	< 70 lpm (30mJ/cm2)

Spares	
Stage 1 filtration:	PL10W20
Stage 2 filtration:	CP10W20
Stage 3 Ultra violet disinfection:	UV lamp UV20LP56 UV Quartz Sleeve UV20QS1

## Maintenance Guidelines

For optimum performance of the UV20 - Replace the UV lamp annually. 9000 hours (12 months) life is set on controller alarm for convenience.

Periodically clean the quartz sleeve to remove staining.

Changeout of filter cartridges is recommended every 12 months.

## Product Dimensions

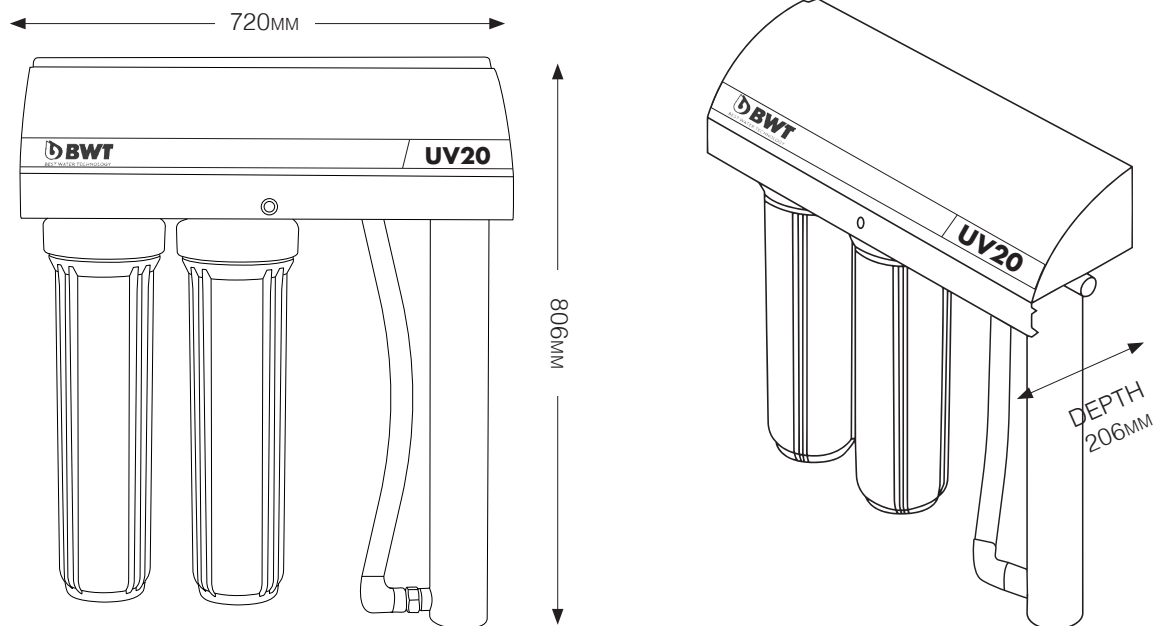

Note: For cartridge change allow 200mm beneath system. For UV lamp change allow 1000mm above system.

## Warranty

BWT Australia warrants that the products supplied will be free from any defects in workmanship or materials for 12 months from the date of purchase. Further, the warranty provided herein applies only when products are installed in accordance with installation instructions, used within the product specifications and service life; beyond which time or use BWT is absolved of any and all liability for any use of the product. No liability is accepted where pressure, temperature or In the event of defect or non-conformity, buyer shall properly notify BWT in writing, supplying proof of purchase dates, installation dates, and will protect and retain the products for investigation. There are no other warranties, either merchantability or fitness, either expressed or implied except as excluded by law.