

posh

Posh Solus MK2 Extended Basin Mixer Tap Chrome (4 Star)

SPECIFICATIONS

| | |
|---------------------------------|--|
| Recommended use | Domestic, hotel and commercial |
| Colour availability | Chrome |
| Pressure rating | Maximum continuous operating pressure 1000 kpa. Note: As per AS3500 pressure must be limited to 500 kpa on any new home, extension or renovation. Note: For best performance and longer life we recommend 150-500 kPa. |
| Temperature rating | Maximum continuous working temperature 65° |
| Suitable Hot Water Units | Storage tank: Yes Continuous Flow: Yes Gravity Feed: Not recommended |
| Standards | AS/NZS 3718 |

WARRANTY

| | |
|---------------------------------|-----------|
| Warranty - Domestic Use | 10 Years |
| Spare Parts & Labour | 12 Months |

Please refer to Warranty Page for full Terms and Conditions

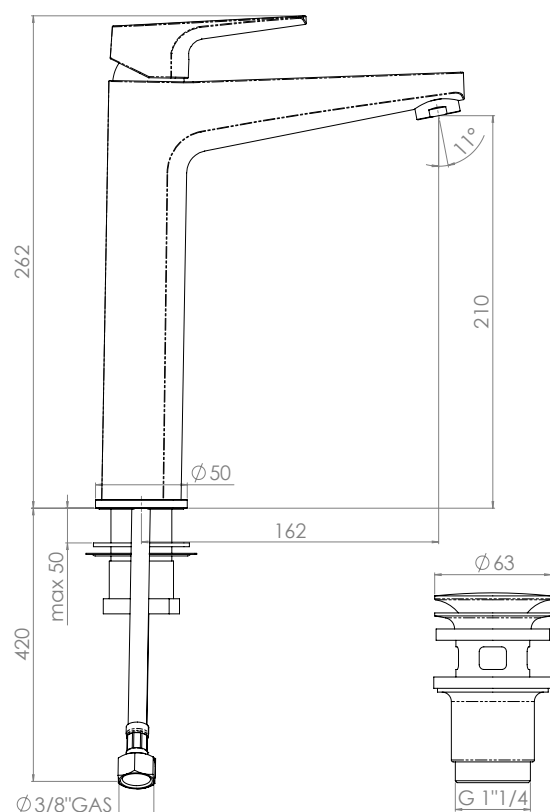

CLEANING RECOMMENDATIONS

We recommend the use of soapy water or approved cleaners. This product should not be cleaned with abrasive materials. Damage caused by any improper treatment is not covered by the product warranty - refer to Warranty Conditions

Disclaimer: Products in this specification manual must by regulation be installed by licensed and registered trade people. The manufacturer/distributor reserves the right to vary specifications or delete models from their range without prior notification. Dimensions are nominal measurements only. Dimensions and set-outs listed are correct at time of publication however the manufacturer/distributor takes no responsibility for printing errors.

Published 16/09/2019

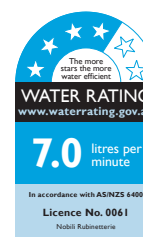

posh

Posh Solus MK2 Extended Basin Mixer Tap Chrome (4 Star)

INSTALLATION INSTRUCTIONS

Note

Mixer must be installed by a qualified plumber.

Important

Your mixer comes to you already factory assembled and tested. We do not recommend the dismantling of any internal part of the mixer. The mixers are factory tested and sealed so as to give the best performance.

1. Please flush out new pipe work prior to connecting the new mixer.
2. All mixers should be installed with isolating stop cocks (Arco).
3. In some areas where the incoming water exceeds 500kpa, an approved pressure limiting device must be installed. Equal pressure for hot and cold water supply is required.
4. Mixers are recommended for use on mains pressure and instantaneous systems only.
5. Place the base washer into position (15).

6. Fit the tap body (12) into the basin hole making sure first that the flexible connectors (20) are firmly tightened into base of the body.
7. Do not use teflon tape on threads.
8. From underneath apply your washer (17) prior to positioning the lock nut (18).
9. Lock the mixer onto the basin by tightening the lock nut (18).

SERVICING - REPLACEMENT OF CARTRIDGE

1. Lift off acrylic indicator cap (1) and unscrew the locking grub screw using allen key.
2. Lift off handle (3) and remove cover dome (4), unscrew brass locking nut (5) and lift out cartridge (8).
3. Replace cartridge (8), replace brass locking nut (5) and replace handle (3). Tighten grub screw (2) and push in indicator cap (1).

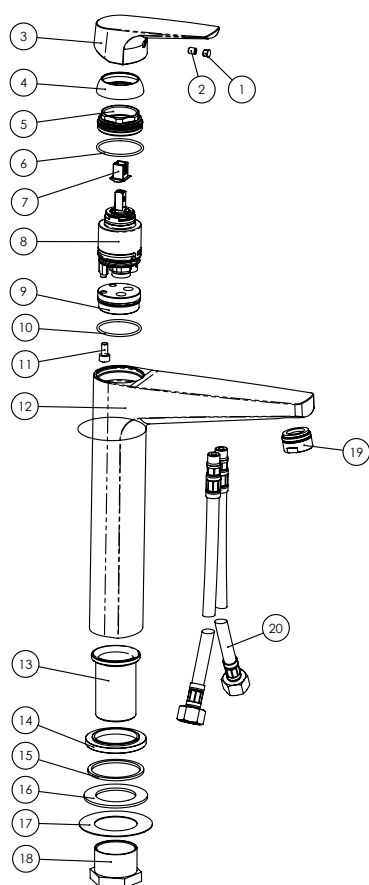

EXPLODED VIEW

| Item | Description |
|------|---------------------------|
| 1 | Indicator cap |
| 2 | Grub screw |
| 3 | Handle |
| 4 | Dome |
| 5 | Locking nut |
| 6 | O-Ring |
| 7 | Thermal cap |
| 8 | Cartridge |
| 9 | Internal adaptor |
| 10 | O-Ring |
| 11 | Internal adaptor screw |
| 12 | Tap body |
| 13 | Shank |
| 14 | Base dress ring |
| 15 | Rubber washer |
| 16 | Rubber washer |
| 17 | Metal washer |
| 18 | Fixing nut |
| 19 | Aerator |
| 20 | Flex tails (hot and cold) |

Plumbers, please ensure a copy of the installation instructions is left with the end user for future reference