

ARMITAGE SHANKS

MARKWIK21 EXPOSED THERMOSTATIC SHOWER MIXER WITH HANDSHOWER OUTLET

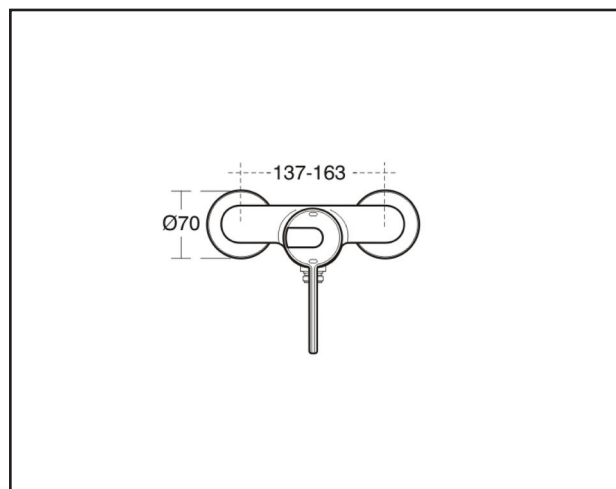
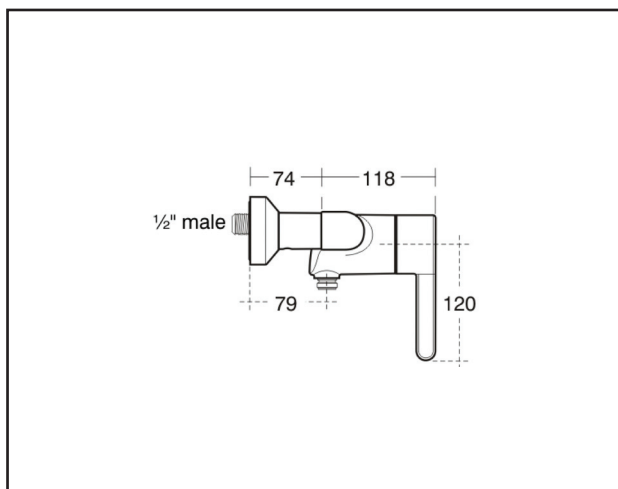

SPECIFICATIONS

Recommended use	Healthcare
Colour availability	Chrome
Pressure rating	Maximum continuous operating pressure 1000 kPa static, 500 kPa dynamic. For best performance and longer life we recommend 100-500kPa. Balanced hot/cold water pressure is preferred but will work on unbalanced pressure up to a ratio of 5:1
Temperature rating	Maximum continuous working temperature 40-41°C
Suitable Hot Water Units	Storage tank: Yes a 20 kPa minimum pressure Continuous Flow: Yes a 20 kPa minimum pressure Gravity Feed: Yes a 20 kPa minimum pressure
Water Efficiency	WELS approval not applicable for thermostatic products
Standards	AS 4032.1: 2005 Thermostatic Valves

Dimensions are nominal measurements only.



To see the complete Armitage Shanks range go to www.reece.com.au/bathrooms

CLEANING RECOMMENDATIONS

When cleaning chromed products use only a mild detergent, rinse & wipe dry with a soft cloth. Ideally clean after each use to maintain appearance.

Never use abrasive, scouring powders or scrapers. Never use cleaning agents containing alcohol, ammonia, hydrochloric acid, sulphuric acid, nitric acid, phosphoric acid or organic solvents. Use of incorrect cleaning products / methods may result in chrome damage which is not covered by the manufacturer's guarantee.

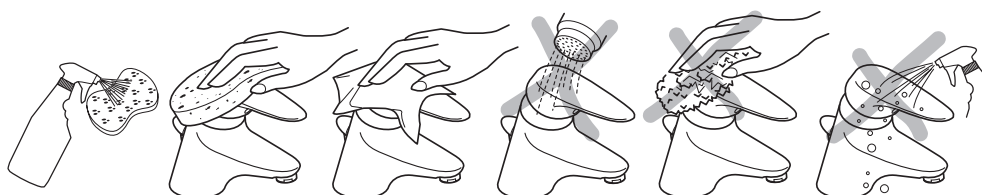

ARMITAGE SHANKS

MARKWIK21 EXPOSED THERMOSTATIC SHOWER MIXER WITH HANDSHOWER OUTLET

Important Note

Mixer must be installed to the requirements of AS/NZS 3500 by a qualified plumber. Your mixer comes to you already factory assembled and tested. We do not recommend the dismantling of any internal part of the mixer. The mixers are factory tested and sealed so as to give the best performance.

INSTALLATION INSTRUCTIONS

5 INSTALLATION GUIDE

5.1 Mounting

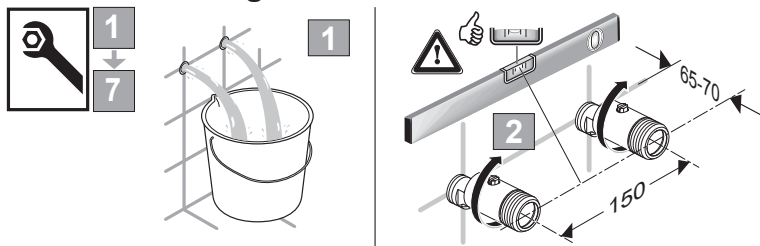

1. Flush pipe work of debris. HOT water supply should be on left side & COLD water supply on the right.

2. Screw the 'S' connectors into the 1/2" female supply nipples preinstalled in the wall. Use a suitable approved jointing medium. S-connectors should be fitted at 150 centres with 65 to 70 horizontal projection from the wall. Use a spirit level to ensure they are horizontal.

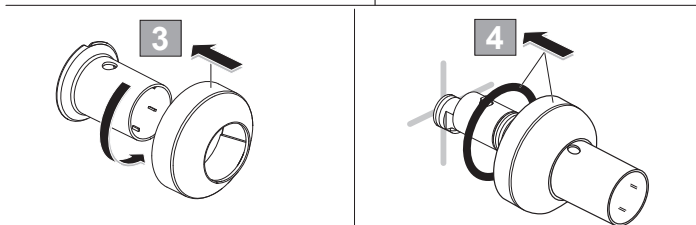

3. Assemble the chrome sleeves & shrouds by screwing together with a couple of turns.

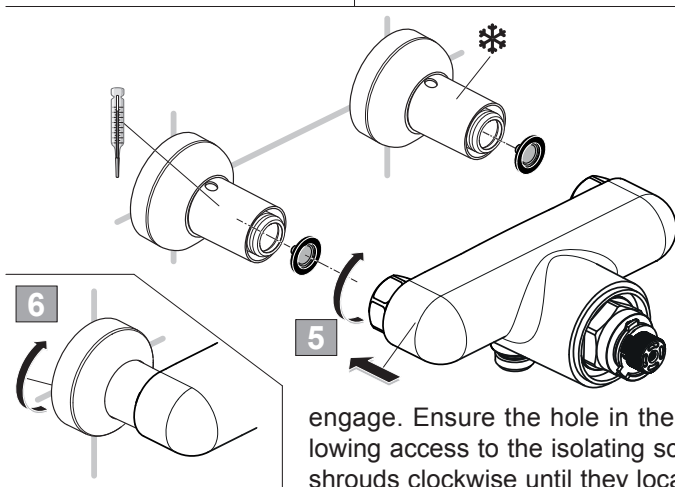

4. Locate wall seals as shown. Place shroud assemblies onto the S-connectors.

5. Assemble the mixer to the inlets using strainer (mesh /filter) washers & tighten the captive nuts with a 30mm A/F spanner.

Fig.3 mounting product

6. Slide the chrome sleeves forwards onto the captive nuts to engage. Ensure the hole in the sleeve is at the top allowing access to the isolating screw. Rotate the chrome shrouds clockwise until they locate against the wall thus concealing the S-connectors

6. Slide the chrome sleeves forwards onto the captive nuts to

Check that all joints are securely tightened, test for leaks.

DO NOT apply heat near this product. Heat generated by soldering could damage plastic parts and seals.



ARMITAGE SHANKS

MARKWIK21 EXPOSED THERMOSTATIC SHOWER MIXER WITH HANDSHOWER OUTLET

6 OPERATION

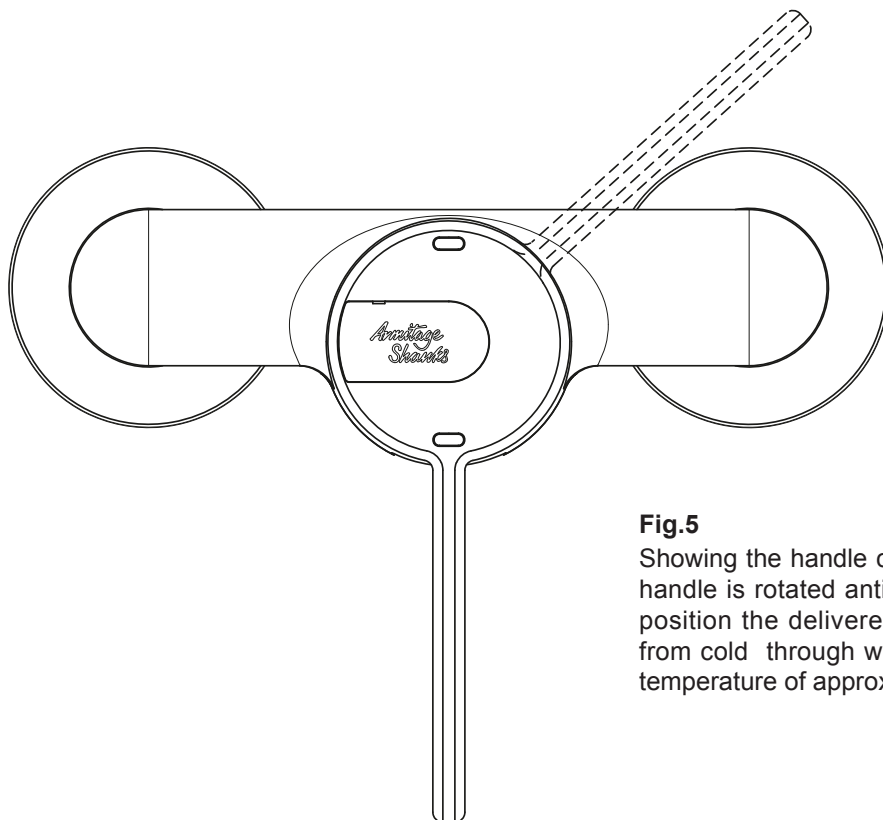

Fig.5

Showing the handle control positions. As the handle is rotated anti-clockwise from the off position the delivered water progresses from cold through warm to the preset max. temperature of approximately 41°C.

7 COMMISSIONING AND AUDITS

The following procedure should be conducted after installation to ensure the product is functioning correctly.

7.1 The Purpose of Commissioning:

- To confirm the correct designation of product versus application.
- To confirm the correct supply water conditions for the product / installation.
- To adjust the mixed temperature if necessary to suit the water supply conditions of the installation.
- To check the product is performing properly.
- To start an audit log and record appropriate data.

This product is factory set at 40±1°C with supplies of circa; 300 KPa balanced pressure and temperatures of 15°C cold & 65°C hot (i.e. an inlet Δt of 50C° & a hot / mix Δt of 24C°)

For supply requirements, see 4.0 Water Supply Conditions.

7.2 Commissioning Process (see decision tree FC1)

- Establish that the supply conditions are within the requirements outlined above. If not investigate.
- When conditions are acceptable record them, together with hot and cold temperatures. Establish Δt.

Check the outlet mix temperature is within 41°C±2°C, if not (probably due to Δt > 5C° difference to factory setting) adjust appropriately. **(see 9.1)**

- If mixed temperature is correct undertake an 'in field' cold water isolation (CWI) test: **(see 7.5)**
 Pass – restore supply and record mixed temperature,
 Fail – **See 7.5 in-field 'Cold Water Isolation' test.**

Plumbers, please ensure a copy of the installation instructions is left with the end user for future reference

ARMITAGE SHANKS MARKWIK21 EXPOSED THERMOSTATIC SHOWER MIXER WITH HANDSHOWER OUTLET

7.2 cont. Commissioning process (decision tree FC1)

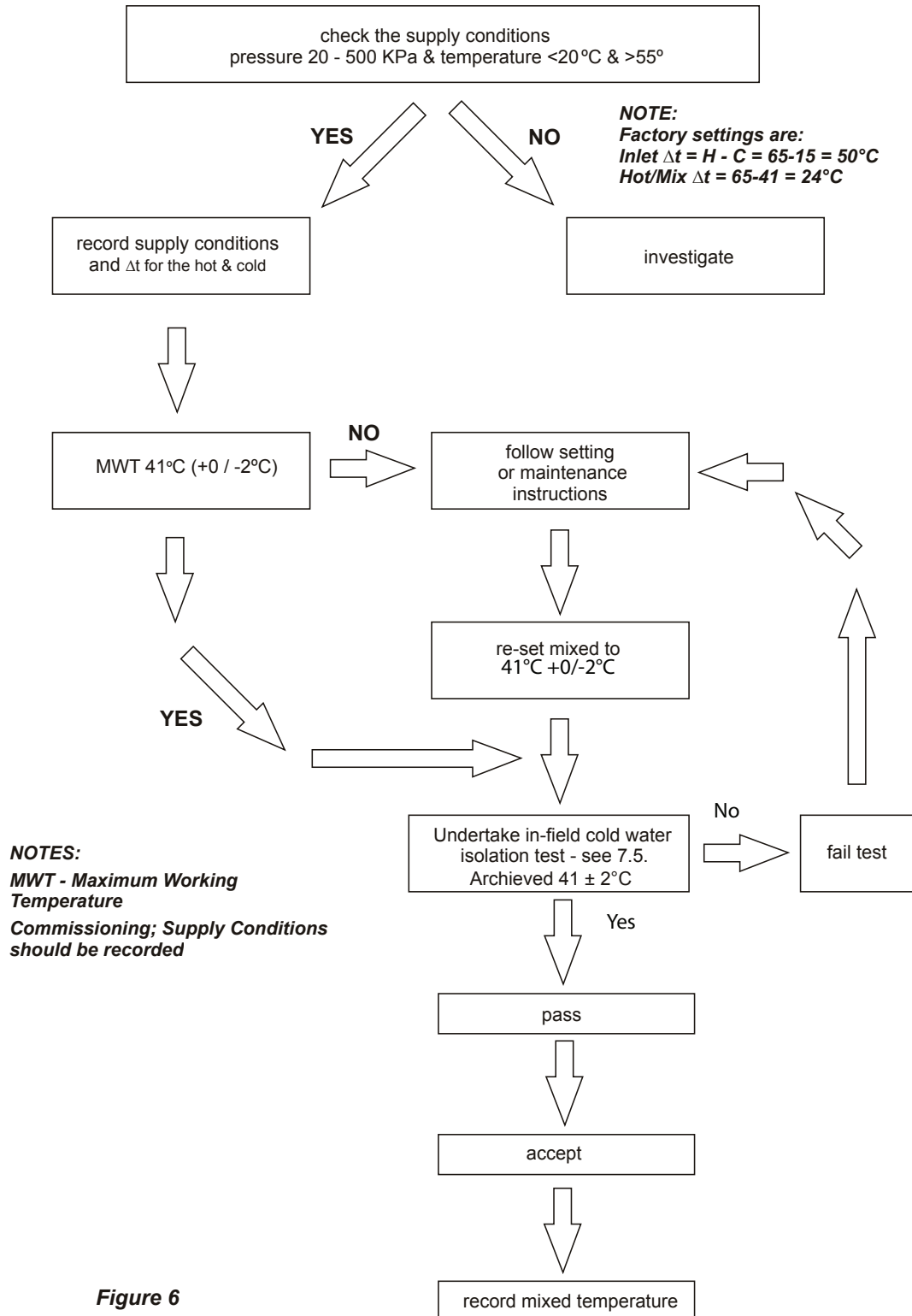

Figure 6

ARMITAGE SHANKS

MARKWIK21 EXPOSED THERMOSTATIC SHOWER MIXER WITH HANDSHOWER OUTLET

7.3 Audit Checks on TMV's

The purpose of a performance audit of a product is:

- ♦ To check the product continues to perform properly.
- ♦ To flag the need for the product to be adjusted due to supply condition changes or mechanism ageing.
- ♦ To ultimately identify the need for product maintenance.

Note - Additionally these audits facilitate regular verification of the supply conditions (See decision tree FC3)

Audit of Supplies To Fittings (FC3)

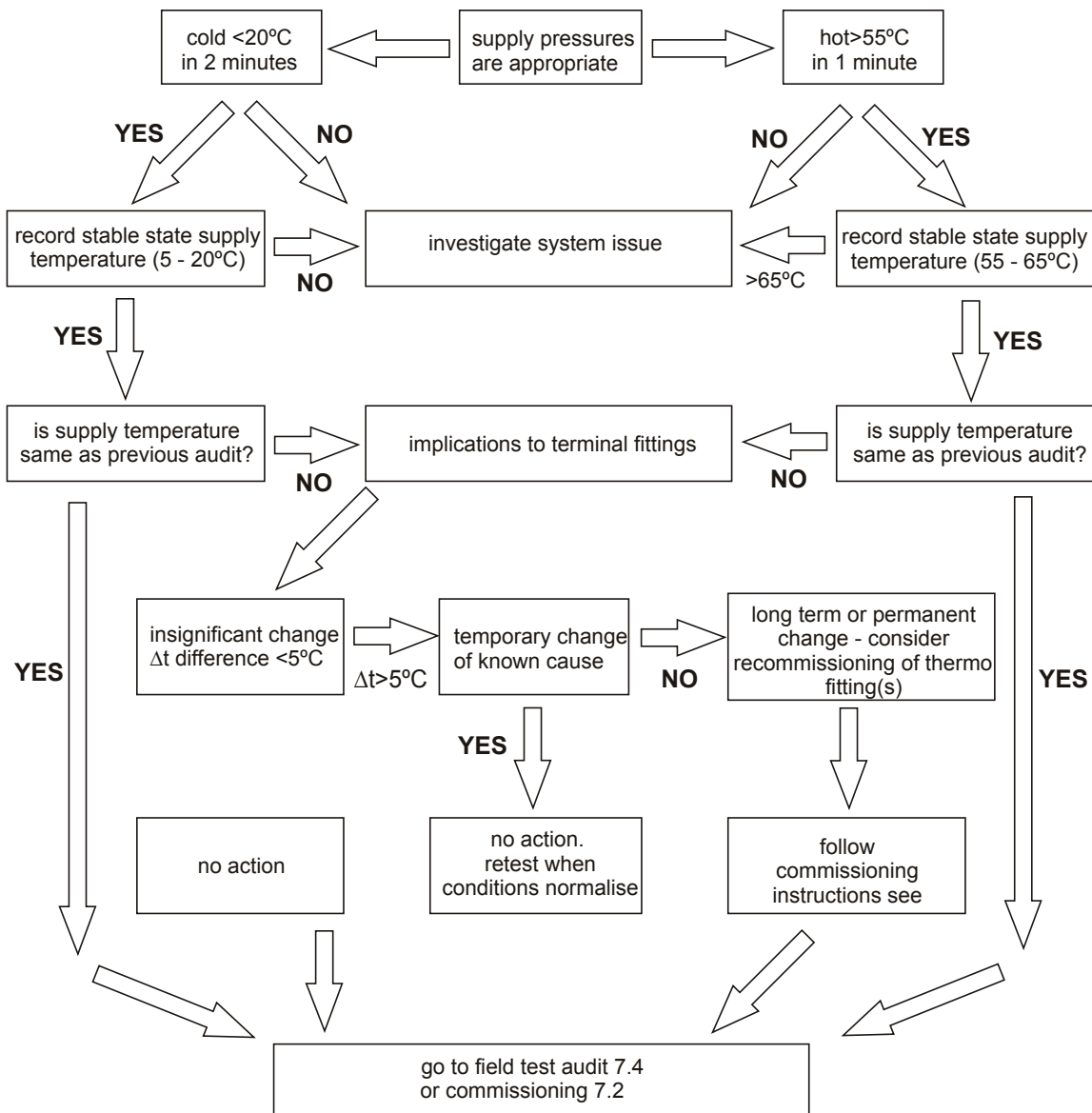

Figure 7

ARMITAGE SHANKS MARKWIK21 EXPOSED THERMOSTATIC SHOWER MIXER WITH HANDSHOWER OUTLET

7.4 Audit procedure (see decision tree FC2)

- Verify the water supplies conditions are similar to when the product was commissioned i.e. inlet Δt as previous + / - 5C°
Note: If inlet Δt change is > 5C° consider the cause of the change, If it is seen as a long term or permanent change, re-commission the product. If however, it is only a temporary change, retest when normal conditions resume.
- If inlet Δt differs from the commissioning Δt by < 5C° carry out field 'cold water isolation' (CWI) test (see 7.5 in field **Cold Water Isolation test failure**).
- Pass - restore the cold supply and move on to check the mix temperature.
Note: If the product fails CWI test, refer to 7.5 and then re-commission the valve.
- Mixed Temperature is as commissioned $\pm 2C^\circ$, Accept and record the temperature.
Note: If mixed Deviation > $\pm 2C^\circ$ (1st instance) reset mix as instructions and redo the test from start. See 9.1 Adjustment of the mix temperature.
- 2nd & subsequent instances follow maintenance instructions.

7.5 In-field 'Cold Water Isolation' (CWI) test.

Locate the cold inline isolating valve on the right hand inlet leg.

Using a flat-blade screw driver, the screw can be rotated 90° anti-clockwise to isolate the cold water supply.

Before commencing the CWI test, ensure:
1. The water supply conditions are met either:
A. For commissioning a new product

B. Or the inlet Δt is within $\pm 5^\circ C$ to when the product was commissioned (see 7.4).

NOTE It is important that the hot temperature is greater than 55°C

2. Mixed water outlet temperature is correct (see table 2, section 8).

Fitting Field Test Audit (FC2)

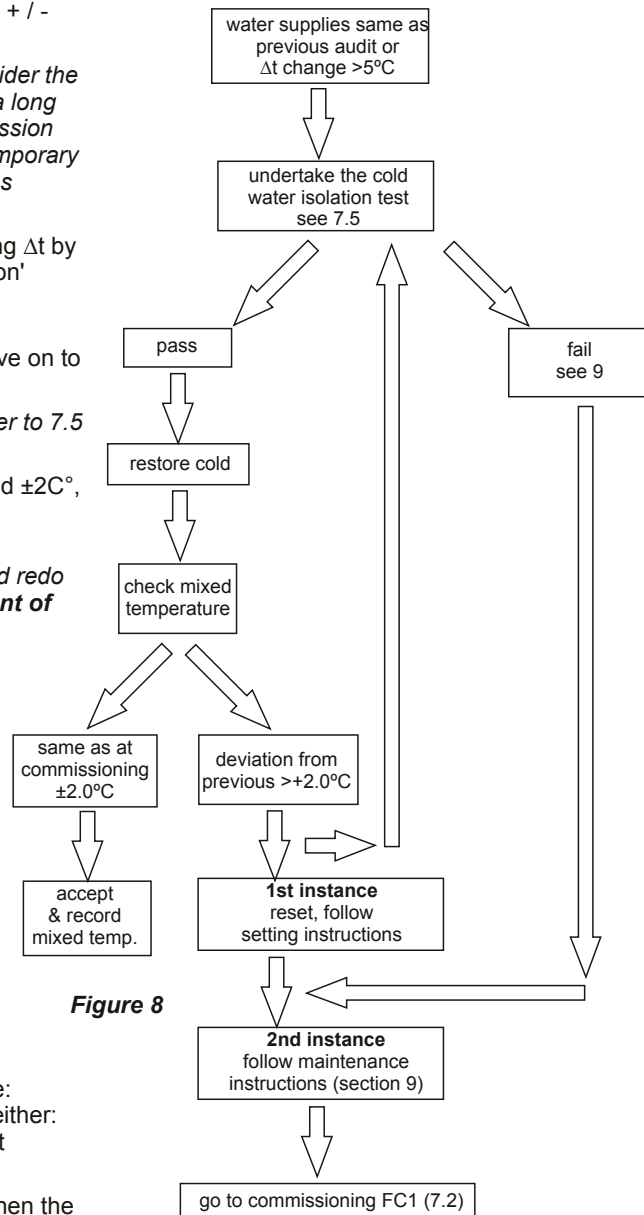

Figure 8

ARMITAGE SHANKS

MARKWIK21 EXPOSED THERMOSTATIC SHOWER MIXER WITH HANDSHOWER OUTLET

To perform a CWI test, operate the product by rotating the lever fully to the right.

Then conduct the following procedure:

1. Record the steady state temperature of both hot and cold water supplies. Note the Δt .
2. Record the temperature of the mixed water at the outlet.
3. Isolate the cold water supply (by rotating the isolating screw 90° & monitor the flow of water from the outlet.

If the flow ceases, CWI test passed:

1. Restore the cold water supply by rotating the isolator screw 90° clockwise.
2. Re-check the temperature of the stabilised mixed water at the outlet to ensure it is still correct.

Accept & record mixed temperature.

If there is an ongoing flow of water from the mixed water outlet, then 5 seconds after CWI collect the discharging water into a measuring vessel for 60 seconds. To pass the CWI test the volume of collected water should be less than 120ml.

If the product fails CWI test, see FC2 (**see section 7.4**). Follow product maintenance (**see section 9**) and servicing (**see section 8**) instructions.

8 SERVICING

The need for servicing is normally identified as a result of the regular performance auditing.

Application	Maximum mixed water temperature during normal operation	Permitted maximum stabilised temperature recorded during site testing - excluding transient spikes
Washbasin	41°C	43°C

Table 2 A guide to maximum temperature sets

8.1 FREQUENCY OF REGULAR SERVICING

The purpose of servicing regularly is to monitor any changes in performance due to changes in either the system or the product. This may highlight the need to adjust either the supply system or the product. These products should be audited 6 to 8 weeks and again 12 to 15 weeks after commissioning. The results are to be compared against original commissioning settings.

If there are no significant changes at the mixed temperature outlet then a 6 monthly servicing cycle may be adopted. Otherwise, servicing checks should be carried out more frequently (e.g. every 4 months).

Follow the recommended auditing and maintenance procedures detailed in sections 7 & 9.

During servicing, note the following:

1. Repeat the procedure of recording and checking supply temperatures. (The same type of measuring equipment should be used)
2. If the temperature has changed significantly from the previously recorded values, the following should be checked:
 - a. All in-line or integral valve filters are clear of obstruction.
 - b. All in-line or integral check valves are clean and working properly to prevent backflow.
 - c. Any isolating valves are fully open.
 - d. The thermostat is free of debris
3. When satisfied with the mixed outlet temperatures re-record the temperatures.

ARMITAGE SHANKS

MARKWIK21 EXPOSED THERMOSTATIC SHOWER MIXER WITH HANDSHOWER OUTLET

9 MAINTENANCE

IMPORTANT NOTE:

When installed in a healthcare application, we recommend that the commissioning and maintenance procedures, detailed under 7 & 8, be carried out.

9.1 Adjustment of the mix temperature

Note: Cartridge is factory pre-set at $40\pm 1^{\circ}\text{C}$ at 300 Kpa.

1. Move the lever to the fully on (max) position.
2. Remove the lever by prising out the cover button and unscrewing the retaining screw using a 4mm Allen key.
3. Remove the upper Anti clockwise stop ring (slide off spindle).
4. Rotate spindle (using lever handle) to achieve correct mix temperature. ($40\pm 1^{\circ}\text{C}$) Rotate clockwise to reduce and anti-clockwise to increase
5. Refit the upper stop ring against cartridge stop face.

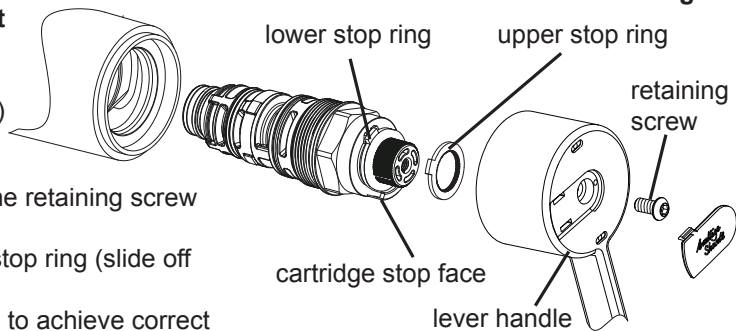

Fig. 9

Note:1. This is the normal maximum temperature range for the product and as such there is a wide zone of spindle movement that gives this mix temperature. For best performance you should refit the stop at the first point of anticlockwise rotation that achieves the desired setting.

Note:2. If you are unable to achieve $40\pm 1^{\circ}\text{C}$ Max and you have the correct Δt 's it may be due to fine debris. **See 9.2 Removal and inspection of cartridge.**

6. Upon successful completion of the temperature adjustment, conduct the **Cold Water Isolation (CWI) test (See 7.5)** to ensure product is working properly.
7. Refit the lever and record the mix temperature.

9.2 Removal and inspection of cartridge

After checking that supply conditions are within the specified parameters, if the fitting malfunctions or should the test results fail to fall within the specified limits consider replacing the cartridge with a new one. **See 9.3 Important notes on debris.**

Isolate the fitting by turning the isolating valves 90° anti-clockwise (viewed facing the iso-valve).

Remove the lever handle as described in 9.1. Unscrew the cartridge from the body with a 36mm a/f deep socket.

Inspect cartridge for damage

Replace cartridge if necessary and reassemble cartridge into body.

The replacement cartridge should be tightened to a torque of 15Nm. (To re-secure the cartridge we recommend the use of Loctite 2400 or equivalent applied to the thread of the cartridge)

Replace lever handle and reinstate the supplies.

After fitting the new cartridge start the test procedure from the section on commissioning.

- Redo the Cold Water Isolation (CWI) test (**See 7.5**)
- Once satisfied with the CWI test, re-check and if necessary, adjust the maximum mix temperature, see (**See 9.1**).
- Record the mix temperature.

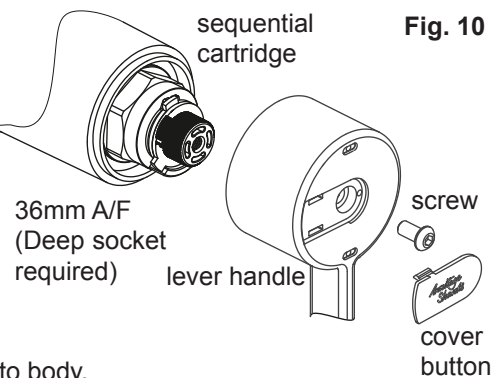

Fig. 10

NOTE: During servicing (or replacing): the thermostatic cartridge fitted in this product does NOT require lubrication.

ARMITAGE SHANKS

MARKWIK21 EXPOSED THERMOSTATIC SHOWER MIXER WITH HANDSHOWER OUTLET

9.3 Important notes on debris

Although this product is protected by the service valve filters, debris can still find its way to the thermostat housing area. This can happen during servicing for example. Remove cartridge (see section 9.2) and carry out an inspection.

9.4 Thermostatic Cartridge Ageing

Following many years of normal service you may notice the following:

1. The need to carry out more frequent adjustment of mixed temperature.
2. The thermostatic element may not pass the CWI test.

These issues could be due to the ageing of the thermostat which loses some expansion capability over time.

These are the principle objectives of testing, as they serve to indicate to maintenance staff the declining performance capability of the thermostatic cartridge.

For this reason the audit testing flow chart highlights that 2nd Instance CWI test failure or 2nd instance mixed deviation even with stable 'as commissioned' supply conditions and correct inlet supply Δt 's, is potentially the first indication of the need to replace the cartridge.

9.5 Isolating the product

Isolation valves facilitate 4 activities:

- | | |
|--------------------------------------|------------------------------------|
| 1) Cleaning strainers & check valves | 2) Servicing the cartridge |
| 3) Disinfection | 4) Audit cold water isolation test |

Strainers

To ensure trouble free operation of the fitting, the strainer elements should be checked and cleaned in accordance with the commissioning and servicing guide. (see section 8)

To isolate this product:

- Unscrew the chrome shrouds.
- Look inside the holes in the chrome sleeves to locate the isolating screws.
- Isolate both water supplies using a flat blade screw driver.

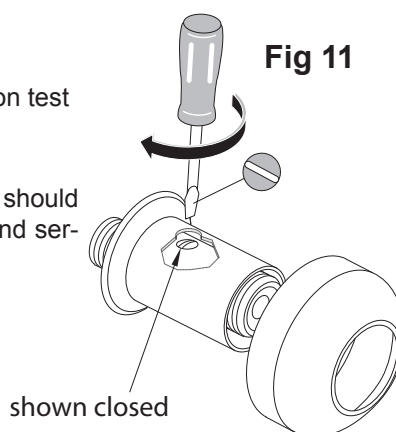

Fig. 11
Operation of isolating valves

ARMITAGE SHANKS

MARKWIK21 EXPOSED THERMOSTATIC SHOWER MIXER WITH HANDSHOWER OUTLET

9.6 Check valve / regulators

To gain access to the check valves, see Fig.12. It will be necessary to demount the product from the wall. Expect a small amount of water to escape during this procedure.

- Isolate both water supplies.
- Slide chrome sleeves towards the wall to disengage them from the captive nuts.
- Using a 30mm A/F spanner, undo the captive nuts.
- Keep the sealing washers in a safe location.
- With product removed, look inside the captive nuts. 10mm hexagonal drive will be visible inside both inlets.
- Using a 10mm hexagonal key, undo the brass housing. This will also release the captive nuts. Carefully pull the check valves out from the bores of the brass housings.
- Check/clean or replace the check valves.
- Reverse this procedure to refit.

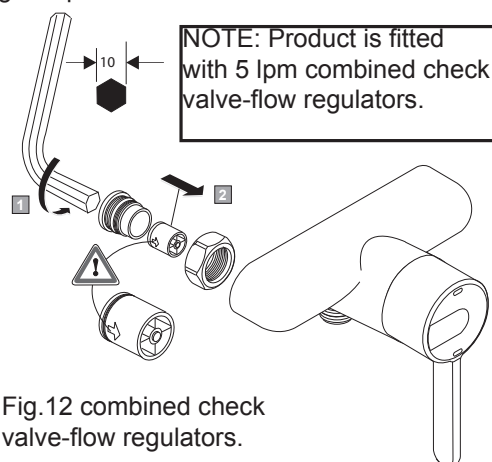

9.7 Disinfection

The design of this product permits quick & easy removal of the mixer for cleaning, disinfection & maintenance purposes.

Disinfection by full immersion in an appropriate bactericidal solution is recommended. Prior to immersion, the fitting should be clean and dismantled to a level that prevents air locking. In some cases it may be considered appropriate to dismantle the fitting prior to demounting.

The level of dismantling should be established as a result of practice and will be largely dependant upon the water quality and service life. As a minimum we recommend removal of the lever handle & thermostatic cartridge. Cleaning the filter screens is of great importance. All components can be immersed together unassembled.

Disinfected mixers should be promptly replaced or stored using an appropriate method until required.

The frequency of such disinfection actions will be derived from regular sampling carried out under the regime of the Responsible Person (Water). We would not expect to need greater than 6 monthly frequencies, hopefully considerably less.

The need for excessive use of this procedure would be indicative of the need for some root cause analysis as there could be some system or behavioural problems that need addressing.

IMPORTANT ADMINISTRATION NOTE:

Where an audit log document (report or electronic record) is being kept for a mixer, consideration should be given to the mixer's traceability during the demounting & disinfecting process.

ARMITAGE SHANKS

MARKWIK21 EXPOSED THERMOSTATIC SHOWER MIXER WITH HANDSHOWER OUTLET

10 SPARE PARTS

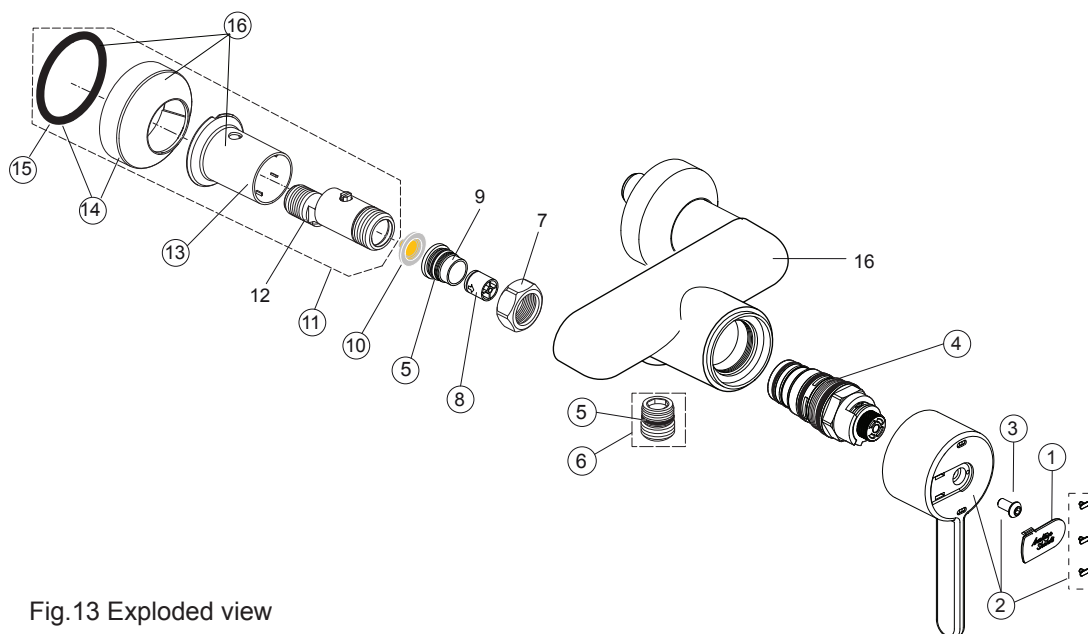

Fig.13 Exploded view

Ref.	Description	Part No.
1	Handle cap with ASH Logo	A 962 017 AA
2	Handle with screw	A 961 456 AA
3	Screw M6x12	A 961 950 NU
4a	Thermostat Cartridge (Single)	A 962 280 NU
4b	Thermostatic Cartridge (10 bulk pack)	F 960 879 NU
5	O-ring Ø17 x 2 (Pair)	A 961 810 NU
6	Connecting nipple complete.	A 860 974 NU
8a	Combined check valve flow regulator CV-FR15	F 961 081 NU
8b	Check valves – simple (pair)	A 962 594 NU
10	Strainer (screen)	A 961 139 NU
11	S-Connector complete	A 860 965 AA
13	Escutcheon inside	A 961 927 AA
14	Escutcheon + Pos. 15	A 961 906 AA
15	O-ring Ø 53,5 x 5	A 963 840 NU
16	Escutcheon complete	B 960 757 AA

Plumbers, please ensure a copy of the installation instructions is left with the end user for future reference

Armitage
Shanks

reece