

# KADO

## SQUARE FLOOR WASTE

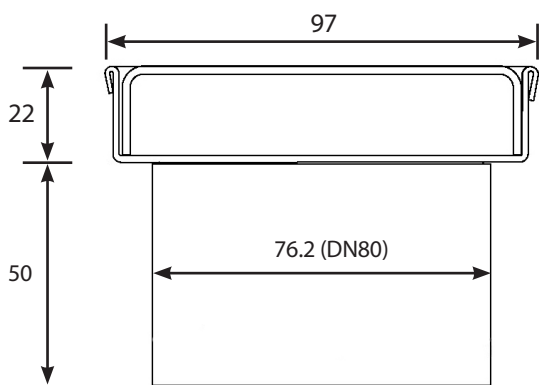
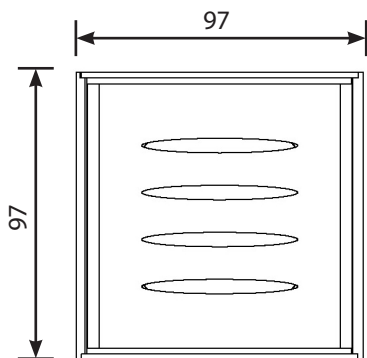

Dimensions are nominal measurements only

### SPECIFICATIONS

<b>Recommended use</b>	Domestic, Hotel and Commercial
<b>Material</b>	316 marine grade stainless steel
<b>Colour availability</b>	Satin stainless, black (powder coat), white (powder coat)
<b>Length</b>	Square 97x97mm
<b>Waste</b>	DN80
<b>Features</b>	Fully welded assembly, 2mm thick heavy wall grate, exterior grade powder coat. 'One drain for whole bathroom' compliant, easy clean grate.
<b>Compliance</b>	WaterMark 21254, heel safe, child safe
<b>Sustainability</b>	Global GreenTag, Level A Gold

Lux Oval



Lux



Lux Square



White option



Black option



### CLEANING RECOMMENDATIONS

We recommend the use of soapy water or approved cleaners.

This product should not be cleaned with abrasive materials.

Damage caused by any improper treatment is not covered by the product warranty. Refer to Warranty Conditions.

To see the complete KADO range go to [www.reece.com.au/bathrooms](http://www.reece.com.au/bathrooms)



**Disclaimer:** Products in this specification manual must by regulation be installed by licensed and registered trade people. The manufacturer/distributor reserves the right to vary specifications or delete models from their range without prior notification. Dimensions and set-outs listed are correct at time of publication however the manufacturer distributor takes no responsibility for printing errors.

Tech Page Version 1



# KADO SQUARE FLOOR WASTE

## INSTALLATION

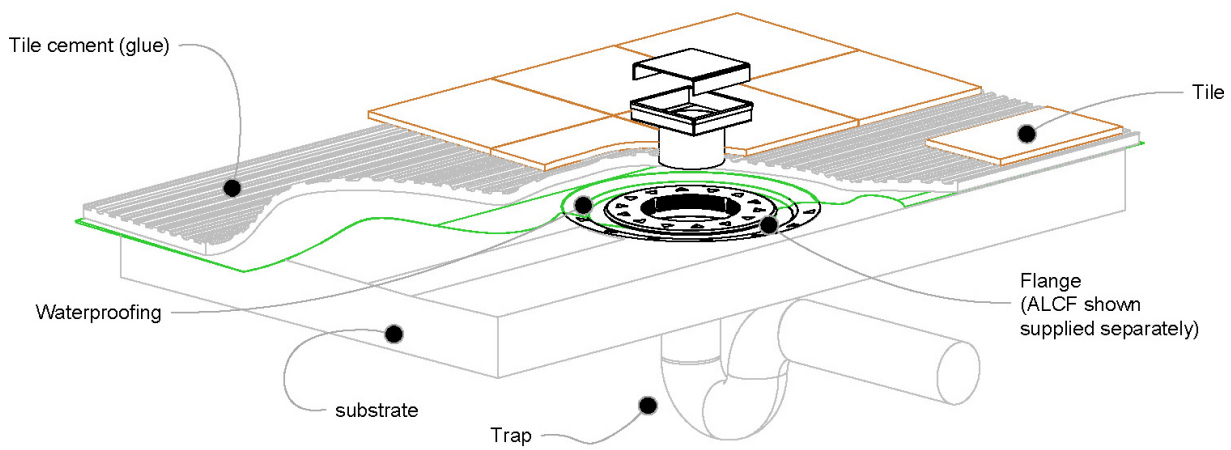
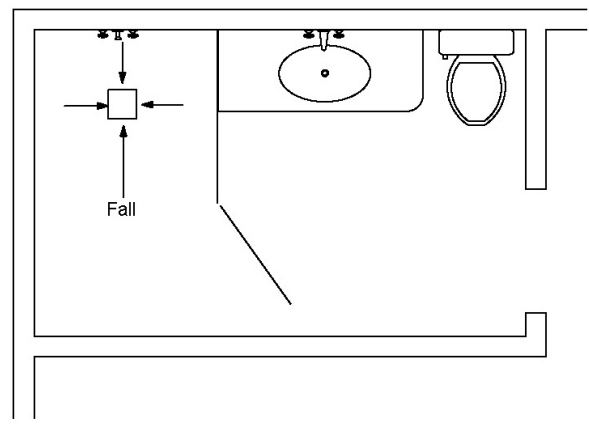

NOTE, this method requires the channel system to be above and separate from the waterproofing

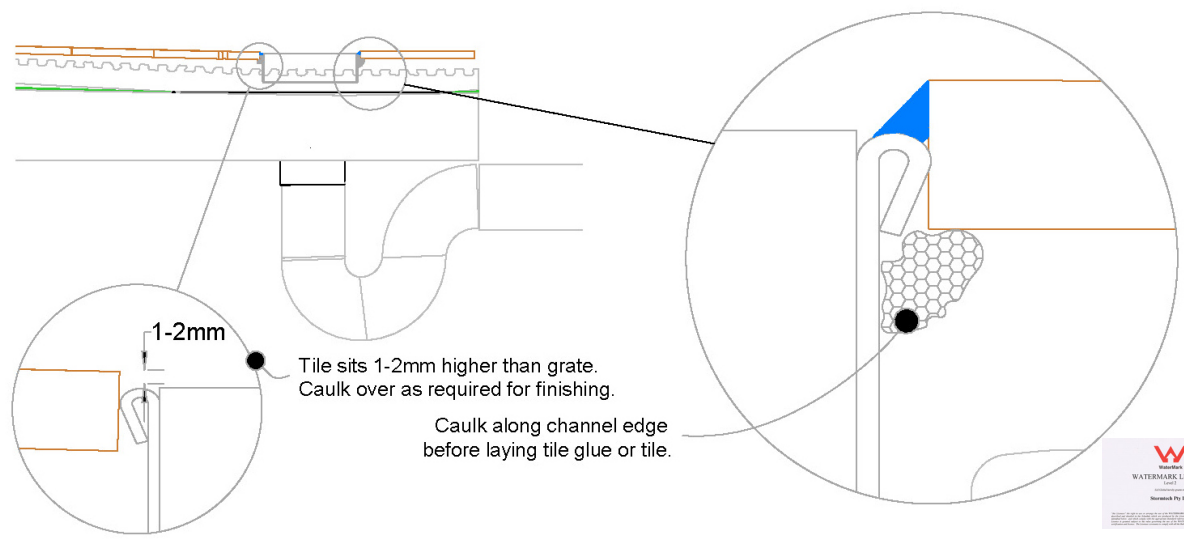

Installation and preparation of the shower or bathroom floor should be as per AS3500 and AS3740.

There are variations of acceptable installations in different jurisdictions around Australia. Check with your local regulator if you are unsure of your local requirements.

Only WaterMark certified products are allowed to be installed. Products without WaterMark certification will be deemed non compliant and removal will be required. This will likely be expensive and time consuming.

Don't risk it, use a licensed plumber.™

# KADO

## SQUARE FLOOR WASTE



### REECE PRODUCT QUALITY GUARANTEE

You have purchased a quality product from Reece Pty Ltd ABN 84 004 097 090 ("Reece"). This product is covered by a 10 year replacement product warranty and a 12 month warranty over spare parts and labour.

#### 10 YEAR WARRANTY – DOMESTIC USE

This warranty covers faults in the product construction and material. Products which are within 10 years from the date of purchase, found upon inspection by an authorised Reece representative, to be defective in construction or material, will be repaired or exchanged with an equivalent product free of charge. Replaced items become Reece's property.

All replacement products will be available for collection without charge to the customer at the nearest Reece branch to the customer's location, or elsewhere as agreed between the customer and Reece.

#### Labour and Spare Parts

The labour for the replacement of products and spare parts to which this warranty applies will be supplied by Reece or relevant supplier using licensed plumbers engaged by Reece or relevant supplier within 1 year from the date of purchase.

Spare parts other which are within 1 year from the date of purchase found upon inspection by an authorised Reece representative to be defective in construction, material or assembly, will be replaced free of charge.

#### Warranty Conditions

This warranty will apply only under all of the following conditions:

- The item has been installed by a licensed plumber
- The item has been installed for and subjected to domestic residential use only
- Failure is due to a fault in the manufacture of the product
- Proof of purchase (including the date of purchase) is provided
- The installation of the product is in accordance with the instructions provided

This warranty does not cover products purchased as an ex-display without being fully checked and tested for sale by the manufacturer.

This warranty does not include faults caused by:

- Unsuitable or improper use
- Incorrect installation or installation not in accordance with the instructions provided
- Installation or part installation by the purchaser or any person other than a LICENSED PLUMBER
- Normal wear and tear
- Inadequate or complete lack of maintenance
- Chemical, electrochemical or electrical influences
- Harsh detergents or abrasive cleaners used on product finishes

#### 1 YEAR WARRANTY – COMMERCIAL USE

'Commercial' use is all use other than for normal domestic residential purposes, including use in non-business places as in public buildings, schools, sports centres and in establishments that contain private bathrooms with high frequency of use by many individuals, such as hotels, motels, retirement villages and hospitals.

The Commercial warranty covers this product against manufacturing faults in the construction or material of both the finished products and any spare parts for a period of 1 year from the date of purchase. Products and spare parts which are found upon inspection by an authorised Reece representative to be defective in construction or material will be repaired or exchanged free of charge. Replaced items become Reece's property. The labour for the replacement of products and spare parts to which this warranty applies will be supplied by Reece or relevant supplier using licensed plumbers engaged by Reece or relevant supplier. The Warranty Conditions and exclusions which apply to the domestic use warranty also apply to this commercial warranty.

#### EXCLUSIONS

To the fullest extent permitted by law, Reece excludes all liability for damage or injury to any person, damage to any property, and any indirect consequential or other loss or damage.

#### CLAIM PROCEDURE

For all warranty queries customers are to contact the branch where the product was purchased. These details can be found on your purchase invoice.

Our goods come with guarantees that cannot be excluded under the Australian Consumer Law. You are entitled to a replacement or refund for a major failure and for compensation for any other reasonably foreseeable loss or damage. You are also entitled to have the goods repaired or replaced if the goods fail to be of acceptable quality and the failure does not amount to a major failure.