

DUCTED AIR CONDITIONER

Owner's Manual

KD Series

KD24

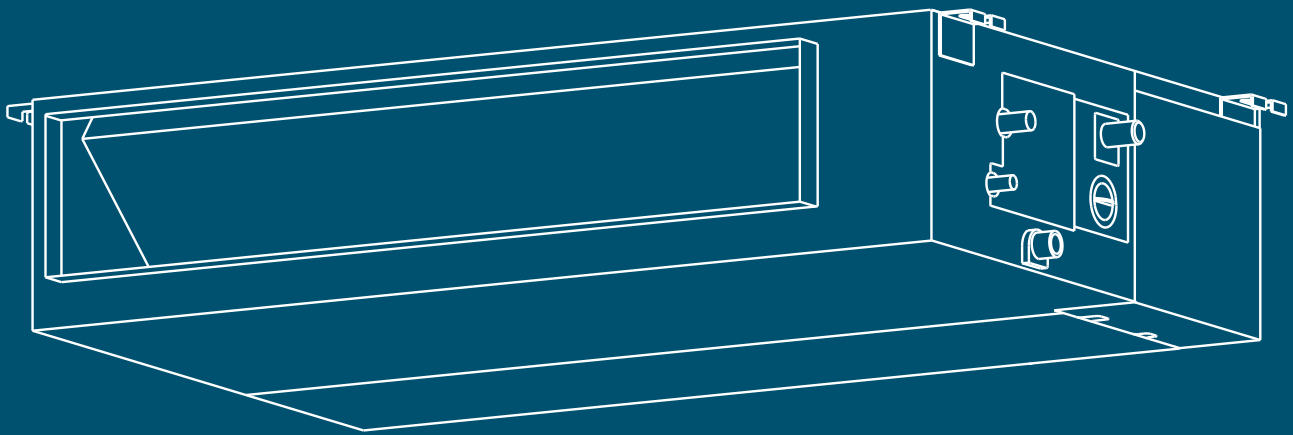

kaden°
TM

Table of Contents

1. Safety Precautions	4
2. Indoor Unit Parts and Major Functions	6
3. Care and Maintenance	8
4. Troubleshooting	10
5. Disposal Guidelines	14

Important note:

Read this manual carefully before installing or operating your new air conditioning unit. Make sure to save this manual for future reference.

1. Safety Precautions

Read Safety Precautions Before Installation

Thank you for purchasing this air conditioner. This manual will provide you with information on how to operate, maintain, and troubleshoot your air conditioner. Following the instructions will ensure the proper function and extended lifespan of your unit.

Please pay attention to the following signs:



This symbol indicates that ignoring instructions may cause death or serious injury.



This symbol indicates that ignoring instructions may cause moderate injury to your person, or damage to your unit or other property.





WARNING

- Ask an authorised technician to install this air conditioner. Inappropriate installation may cause water leakage, electric shock, or fire.
- The warranty will be voided if the unit is not installed by a licensed person.
- If an abnormal situation arises (like burning smell), turn off the power supply and call a licensed installer for instructions to avoid electric shock, fire or injury.
- **Do not** let the indoor unit or the remote control get wet. It may cause electric shock or fire.
- **Do not** insert fingers, rods or other objects into the air inlet or outlet. This may cause injury, since the fan may be rotating at high speeds.
- **Do not** use a flammable spray such as hair spray, lacquer or paint near the unit. This may cause fire or combustion.

! CAUTION

- **Do not** inspect the unit by yourself. Ask an authorised installer to perform the inspection.
- To prevent product deterioration, do not use the air conditioner for preservation purposes (storage of food, plants, animals, works of art, etc.).
- **Do not** touch the evaporator coils inside the indoor unit. The evaporator coils are sharp and may cause injury.
- **Do not** operate the air conditioner with wet hands. It may cause electric shock.
- **Do not** operate the air conditioner when using fumigant insecticides. The chemicals may become layered with the unit and endanger those who are hypersensitive to chemicals.
- **Do not** let children play with the air conditioner.
- If the air conditioner is used together with other heating devices, thoroughly ventilate the room to avoid oxygen deficiency.
- **Do not** climb onto or place objects on top of the outdoor unit.
- The air conditioner can be used by children aged 8 years and older and people with reduced physical, sensory or mental capabilities, or lack of experience and knowledge, if they have been given instruction on how to properly and safely operate the system.
- **Do not** operate the air conditioner in a wet room (e.g. bathroom or laundry room). This can cause electrical shock and cause the product to deteriorate.
- An all-pole disconnection device which has at least 3mm separation distance in all pole and a residual current device (RCD) with the rating of above 10mA shall be incorporated in the fixed wiring according to the national rule.
- The appliance shall be installed in accordance with national wiring regulations.
- Children should be supervised to ensure that they do not play with the appliance.

 WARNING	
<p>KEEP OUT OF REACH OF CHILDREN This product contains button / coin cell batteries. Keep new and used batteries away from children. A swallowed button or coin cell battery can cause internal chemical burns and death in as little as two hours. Dispose of unused batteries immediately. If you think batteries might have been swallowed or placed inside any part of the body, seek immediate medical attention.</p>	



'If it is suspected a button/coin battery has been swallowed or otherwise placed inside any part of the body, a person should contact the Australian Poisons Information Centre on 13 11 26 or National Poisons Centre on 0800 764 766 (New Zealand) immediately for 24/7 fast, expert advice.'

2. Indoor Unit Parts and Major Functions

Unit Parts

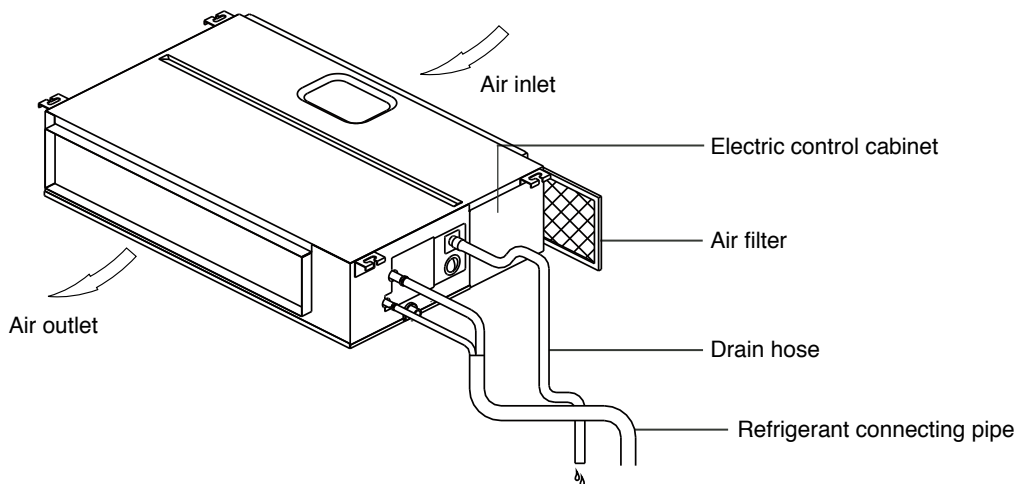

Operating Conditions

Use the system under the following temperatures for safe and effective operation. If the air conditioner is used under different conditions, it may malfunction or become less efficient.

	COOL mode	HEAT mode	DRY mode
Room Temperature	17°C – 32°C	0°C – 30°C	17°C – 32°C
Outdoor Temperature	-15°C – 50°C	-15°C – 24°C	0°C – 50°C

Features

Default Setting

When the air conditioner restarts after a power failure, it will default to the factory settings (AUTO mode, AUTO fan, 24°C). This may cause inconsistencies on the remote control and unit panel. Use your remote control to update the status.

Auto-Restart

In case of power failure, the system will immediately stop. When power returns, the Operation light on the indoor unit will flash. To restart the unit, press the **ON/OFF** button on the remote control. If the system has an auto restart function, the unit will restart using the same settings.

Energy Saving Tips

- **Do not** set the unit to excessive temperature levels.
- While cooling, close the curtains to avoid direct sunlight.
- Doors and windows should be kept closed to keep cool or warm air in the room.
- Set a timer and use the built-in **SLEEP/ECONOMY** mode if applicable.
- Clean the air filter regularly.

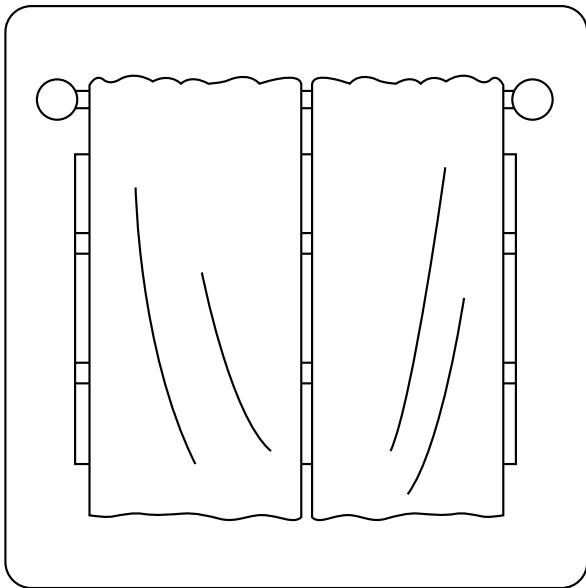

Closing curtains during heating also helps keep the heat in

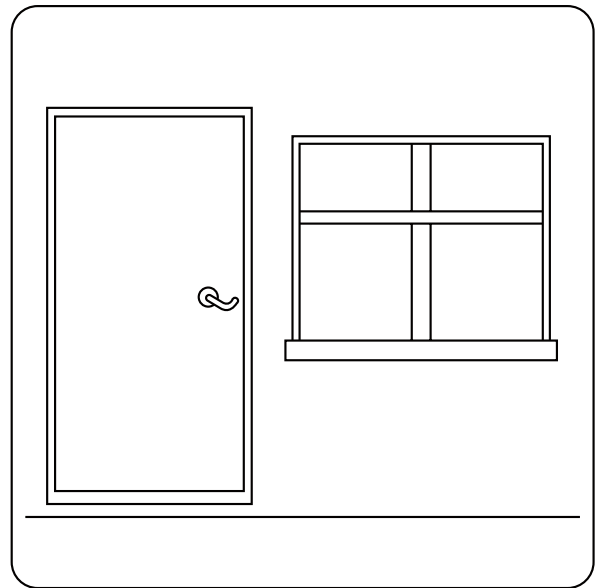

Doors and windows should be kept closed

3. Care and Maintenance

Safety Precautions

- Contact an authorised service technician for repair or maintenance. Improper repair and maintenance may cause water leakage, electrical shock, or fire, and may void your warranty.
- **Do not** substitute a blown fuse with a higher or lower amperage rating fuse, as this may cause circuit a or an electrical fire.
- Make sure the drain hose is set up according to the instructions. Failure to do so could cause leakage and result in personal property damage, fire and electric shock.
- Make sure that all wires are connected properly. Failure to connect wires according to instructions can result in electrical shock or fire.

Unit Maintenance

! Before Cleaning or Maintenance

- Always turn off your air conditioning system and disconnect the power supply before cleaning or maintenance.
- **Do not** use chemicals or chemically treated cloths to clean the unit.
- **Do not** use benzene, paint thinner, polishing powder or other solvents to clean the unit. They can cause the plastic surface to crack or deform.
- **Do not** wash the unit under running water. Doing so creates an electrical hazard.

How to Clean the Air Filter

The filter prevents dust and other particles from entering the indoor unit. Dust buildup can reduce the efficiency of the air conditioner. For optimum efficiency, clean the air filter every two weeks or more frequently if you live in a dusty area. Replace the filter with a new one if it's heavily clogged and cannot be cleaned.



WARNING: DO NOT REMOVE OR CLEAN THE FILTER BY YOURSELF

Removing and cleaning the filter can be dangerous. Removal and maintenance must be performed by a certified technician.

Note

In households with animals, you will have to periodically wipe down the grille to prevent animal hair blocking airflow.

1. If the unit you purchased is a rear ventilated one, take off the filter in the directions indicated by the arrows in the following diagram.

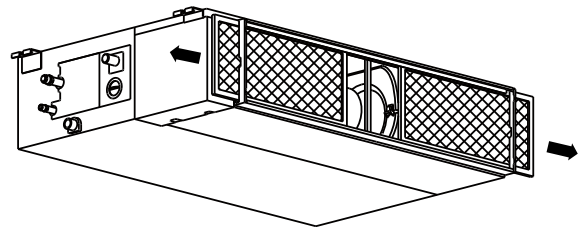

2. If the unit you purchased is a descensional ventilated model, take off the filter in the directions indicated by the arrows in the following diagram.

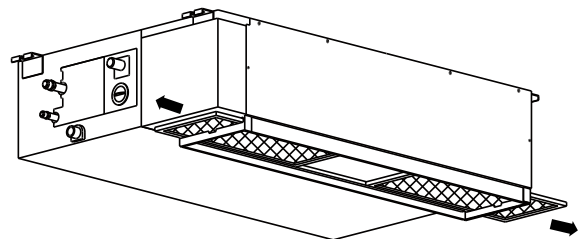

3. Remove the air filter.
4. Clean the air filter by vacuuming the surface or washing it in warm water with mild detergent.
 - A. If using a vacuum cleaner, the inlet side should face the vacuum.

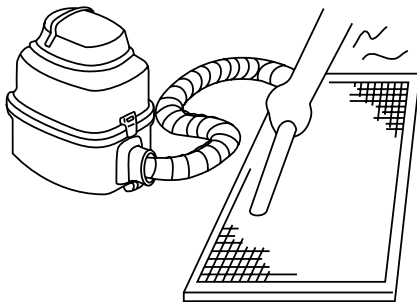

- B. If using water, the inlet side should face down and away from the water stream.

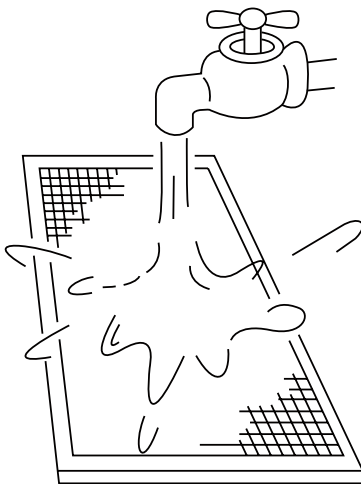

5. Rinse the filter with clean water and allow it to air-dry. **Do not** let the filter dry in direct sunlight.
6. Reinstall the filter.

Repairing Refrigerant Leaks

WARNING

- If the refrigerant leaks, turn off the air conditioner and any combustible heating devices, ventilate the room and call your dealer immediately. Refrigerant is both toxic and flammable. **Do not** use the air conditioner until the leak is repaired.
- When the air conditioner is installed in a small room, measures must be taken to prevent the refrigerant concentration from exceeding the safety limit in the event of refrigerant leakage. Concentrated refrigerant causes a severe health and safety threat.

Preparation for Periods of Non-Use

Maintenance after Extended Non-Use

1. Remove any obstacles blocking the vents of both the indoor and outdoor units.
2. Turn on the main power switch at least 12 hours prior to operating the unit.

Storing the Unit While Not in Use

1. Run the appliance on **FAN** mode for 12 hours in a warm room to dry it and prevent mold.
2. Turn off the appliance.
3. Clean air filter according to the instructions in the previous section. Reinstall the clean, dry filter before storing.

4. Troubleshooting

! CAUTIONS

If one of the following conditions occurs, switch off the power supply immediately and contact a HVAC professional for further assistance.

- The operation light continues to flash rapidly after the unit has been restarted.
- The remote control buttons do not work.
- The unit continually trips fuses or circuit breakers.
- A foreign object or water enters the air conditioner.
- Other abnormal situations.

Common Problems

The following symptoms are not a malfunction and in most situations will not require repairs.

Issue	Possible Causes
Unit does not turn on when pressing ON/OFF button	The unit has a 3-minute protection feature that prevents the unit from overloading. The unit cannot be restarted within three minutes of being turned off.
	Cooling and Heating Models: If the Operation light and PRE-DEF (Pre-heating/Defrost) indicators are lit up, the outdoor temperature is too cold and the unit's defrost cycle is activated in order to defrost the unit.
	In Cooling-only Models: If the "Fan Only" indicator is lit up, the outdoor temperature is too cold and the unit's anti-freeze protection is activated in order to defrost the unit.
The unit changes from COOL mode to FAN mode	The unit changes its setting to prevent frost from forming on the unit. Once the temperature increases, the unit will start operating again.
	The set temperature has been reached, at which point the unit turns off the compressor. The unit will resume operating when the temperature fluctuates again.
The indoor unit emits white mist	In humid regions, a large temperature difference between the room's air and the conditioned air can cause white mist.

Issue	Possible Causes
Both the indoor and outdoor units emit white mist	When the unit restarts in HEAT mode after defrosting, white mist may be emitted due to moisture generated from the defrosting process.
The indoor unit makes noises	A squeaking sound is heard when the system is OFF or in COOL mode. The noise is also heard when the drain pump is in operation.
	A squeaking sound may occur after running the unit in HEAT mode due to expansion and contraction of the unit's plastic parts.
Both the indoor unit and outdoor unit make noises	A low hissing sound may occur during operation. This is normal and is caused by refrigerant gas flowing through both the indoor and outdoor units.
	A low hissing sound may be heard when the system starts, has just stopped running or is defrosting. This noise is normal and is caused by the refrigerant gas stopping or changing direction.
The outdoor unit makes noises	The unit will make different sounds based on its current operating mode.
Dust is emitted from either the indoor or outdoor unit	The unit may accumulate dust during extended periods of non-use, which will be emitted when the unit is turned on. This can be mitigated by covering the unit during long periods of inactivity.
The unit emits a bad odor	The unit may absorb odors from the environment (such as furniture, cooking, cigarettes, etc.) which will be emitted during operations.
	The unit's filters have become moldy and should be cleaned.
The fan of the outdoor unit does not operate	During operation, the fan speed is controlled to optimize product operation.

Troubleshooting Tips

When troubles occur, please check the following points before contacting a repair company.

Problem	Possible Causes	Solution
The unit is not working	Power failure.	Wait for the power to be restored.
	The power switch is off.	Turn on the power.
	The fuse is burned out.	Replace the fuse.
	The unit's 3-minute protection has been activated.	Wait three minutes after restarting the unit.
Poor cooling performance	Temperature setting may be higher than the ambient room temperature.	Lower the temperature setting.
	The heat exchanger on the indoor or outdoor unit is dirty.	Clean the affected heat exchanger.
	The air filter is dirty.	Remove the filter and clean it according to instructions.
	The air inlet or outlet of either unit is blocked.	Turn the unit off, remove the obstruction and turn it back on.
	Doors and windows are open.	Make sure that all doors and windows are closed while operating the unit.
	Excessive heat is generated by sunlight.	Close windows and curtains during periods of high heat or bright sunshine.
	Low refrigerant due to leak.	Call service agent.
The unit starts and stops frequently	There's too much or too little refrigerant in the system.	Call service agent.
	The compressor is broken.	Replace the compressor.
Poor heating performance	The outdoor temperature is lower than 7°C.	Check for leaks and recharge the system with refrigerant.
	Cold air is entering through doors and windows.	Make sure that all doors and windows are closed during use.
	Low refrigerant due to leak.	Call service agent.

Error Codes

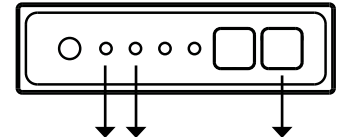
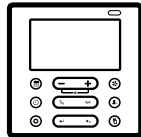

Number	Cause	The number of flashes per second	Timer indicator	Error Code
1	Indoor EEPROM (Electrically Erasable Programmable Read-Only Memory) error	1	Off	E0
2	Indoor and outdoor unit communication malfunction	2	Off	E1
3	Indoor fan speed malfunction	4	Off	E3
4	Indoor room temperature sensor error	5	Off	E4
5	Evaporator coil temperature sensor error	6	Off	E5
6	Refrigerant leak detection system malfunction	7	Off	EC
7	Water level alarm malfunction	8	Off	EE
8	Dual indoor unit (twin model only) communication malfunction	9	Off	E8
9	Other twin model malfunction	10	Off	E9
10	Overload protection	1	On	F0
11	Outdoor temperature sensor error	2	On	F1
12	Outdoor condenser pipe sensor error	3	On	F2
13	Discharge air temperature sensor error	4	On	F3
14	Outdoor EEPROM (Electrically Erasable Programmable Read-Only Memory) error	5	On	F4
15	Outdoor fan speed (DC fan motor only) malfunction	6	On	F5
16	Inverter module IPM protection	1	Flash	P0
17	High/Low voltage protection	2	Flash	P1
18	Compressor top overheating protection	3	Flash	P2
19	Outdoor low temperature protection	4	Flash	P3
20	Compressor drive error	5	Flash	P4
21	Mode conflict	6	Flash	P5
22	Compressor low-pressure protection	7	Flash	P6
23	Outdoor IGBT sensor error	8	Flash	P7
24	Indoor unit communication malfunction	11	On	FA

5. Disposal Guidelines

This appliance contains refrigerant and other potentially hazardous materials. When disposing of this appliance, the law may require special collection and treatment.

Do not dispose of this product as household waste or unsorted municipal waste.

When disposing of this appliance, you have the following options:

- Dispose of the appliance at designated municipal electronic waste collection facility.
- Sell the appliance to certified scrap metal dealers.

Note

Disposing of this appliance in the forest or other natural surroundings endangers your health and is bad for the environment. Hazardous substances may leak into the ground water and enter the food chain.

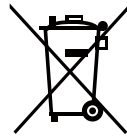

Notes

kaden°

kadenair.com.au