

Posh Solus Mk3 Standard Sink Mixer (4*)

Mixer must be installed to the requirements of AS/NZS 3500 by a qualified plumber. Your mixer comes to you already factory assembled and tested. We do not recommend the dismantling of any internal part of the mixer. The mixers are factory tested and sealed so as to give the best performance.

Installer is responsible for ensuring water connections to the mixer body are watertight.

INSTALLATION REQUIREMENTS:

1. Flush out new pipe work prior to connecting the new mixer.
2. Place the base washer from the fixing kit (11) over the tap hole.
3. Pass the pre-fitted hot and cold hoses (12) through the tap hole and sit the base of the sink mixer on top of the tap hole. Ensure that the base washer sits firmly inside the sink mixer dress ring (10).
4. Underneath the mounting surface, secure the horseshoe plate and retaining nut from the fixing kit (11) to the sink mixer's shank, making sure the rubber side of the horseshoe plate is contacting the under surface. Undermount sink stabiliser must be used if installing the mixer directly onto a stainless-steel sink hole.
5. Cold water supply must be fitted to blue coloured hose and hot water supply must be fitted to red colour hose.
6. Fastening nuts on pre-fitted flexible hoses (12) must be installed to a water supply utilising compliant 1/2" male BSP threads. It is recommended that both the cold and hot water supply have a means of isolating the supply.
7. Hose fastening nuts must be tightened by hand plus an additional half a turn of tightening using a wrench.

NOTE:

- **Do not bend hoses in a manner that will cause them to kink and deform**
- **Water supply flexible hoses are pre-fitted fitted to the mixer. Do not attempt to remove hoses from mixers**
- **Mixer must be installed only with pressurised hot water storage and instantaneous water systems only**

SERVICING - REPLACEMENT OF CARTRIDGE:

1. Disassemble the handle (1) from the mixer body by removing the locking grub screw cap and unscrewing the locking grub screw with a 1.5 mm Allen key.
2. Unscrew the cartridge dome (2) and use a wrench to unscrew the cartridge locknut (3).
3. Remove and replace the mixer cartridge (4). Reassemble the locknut (3), cartridge dome (2) and handle assembly (1).
4. Test reassembled mixer for leaks.

CLEANING RECOMMENDATIONS

We recommend the use of soapy water or approved cleaners.

This product should not be cleaned with abrasive materials.

Damage caused by any improper treatment is not covered by the product warranty - refer to Warranty Conditions.

Please ensure a copy of the installation instructions is left with the end user for future reference.

Posh Solus Mk3 Standard Sink Mixer (4*)

EXPLODED DIAGRAM:

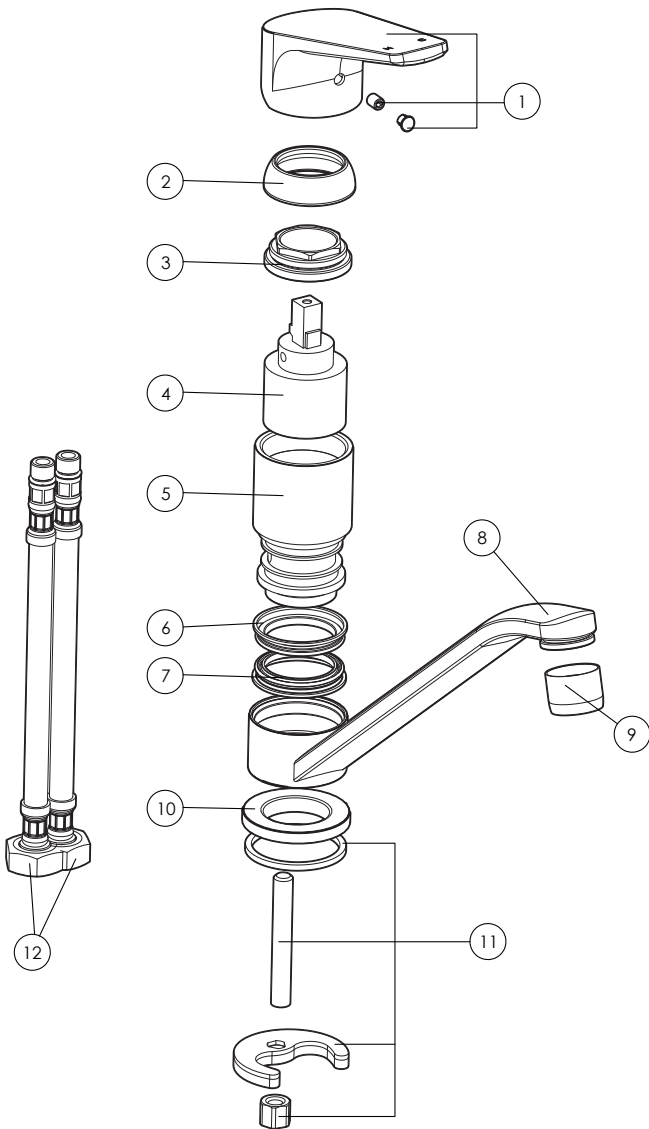

Number	Part	Code
1	Handle complete	2250686
2	Cartridge dome	
3	Cartridge locknut	
4	Cartridge	2250688
5	Mixer body	
6	Seal	
7	Seal	
8	Mixer spout	
9	Aerator complete	2250691
10	Dress ring	
11	Fixing kit	2250692
12	Hoses (hot and cold)	2250684

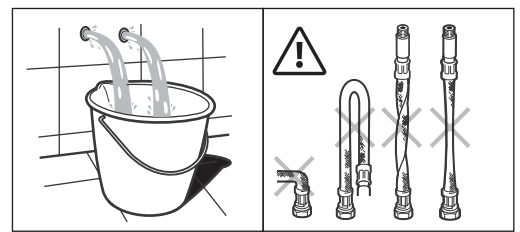

	P	P bar	MIN 0,5	MAX. 10	
	T	°C	-80 MAX.		

Please ensure a copy of the installation instructions is left with the end user for future reference