



# Milli Zato Shower Mixer & Diverter

## INSTALLATION INSTRUCTIONS

### IMPORTANT NOTE

Mixer must be installed to the requirements of AS/NZS 3500 by a qualified plumber. Your mixer comes to you already factory assembled and tested. We do not recommend the dismantling of any internal part of the mixer. The mixers are factory tested and sealed so as to give the best performance.

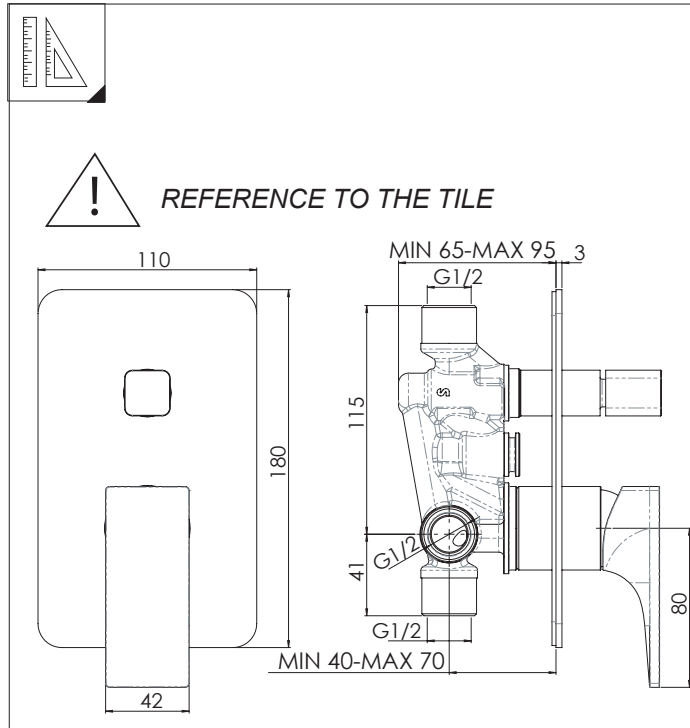

BEFORE STARTING						
	P	P bar				T
					T	°C

CLEANING				
WATER	ALCOHOL	MICROFIBER	SPONGE	DETERGENT

Plumbers, please ensure a copy of the installation instructions is left with the end user for future reference.



# Milli Zato Shower Mixer & Diverter

## INSTALLATION INSTRUCTIONS

1

Not included / Non incluso / Non Inclus / Nie-zawarty/ No incluido / Nao incluido

A

NOT INCLUDED

B

STANDARD POSITION

2

A

HOT

COLD

3

TEST

TEST FOR THE PIPES BEFORE CARTRIDGE (A)

ATTENTION! During test cartridge must be placed in "CLOSED POSITION"

TEST FOR THE PIPES AFTER CARTRIDGE (B)

ATTENTION! As per european rule EN817, in case of test for the pipes after cartridge, the pressure must be within 4 bar for 1 minute, and the cartridge in "open position"

4

7

5

SILICONE

B

7

EXTENSION NOT INCLUDED NR00212/13

> MAX

6

OPTIONAL

Non-return valve ONLY for bath filling and overflow sets

CH 10 mm

8

CHANGE POSITION