

# THERMANN EVACUATED TUBE SOLAR - GAS

## SPECIFICATIONS

Gas Boosted Tank			
Measurements (mm)	250L GAS	315L GAS	400L GAS
Tank Diameter	617	617	705
Tank Height	1445	1765	1704
HW Outlet	1211	1531	1445
PTRV Port	1211	1531	1445
Top Sensor Port	992	1258	1208
Solar Return Port	764	953	932
Bottom Sensor	457	551	554
Solar Flow	197	197	219
Cold Water Inlet	197	197	219
Dry Weight (kg)	71	92	116



Roof Collector Measurements (mm)		Dry Weight		
Collector	Width (A)	Length (B)	WO/Tubes	W/Tubes
22 Tubes	1636	2005	20kg	80.7kg
30 Tubes	2196	2005	24kg	105.7kg

Dry weights based on 2 track flush mount frame

## PRODUCT DIMENSIONS

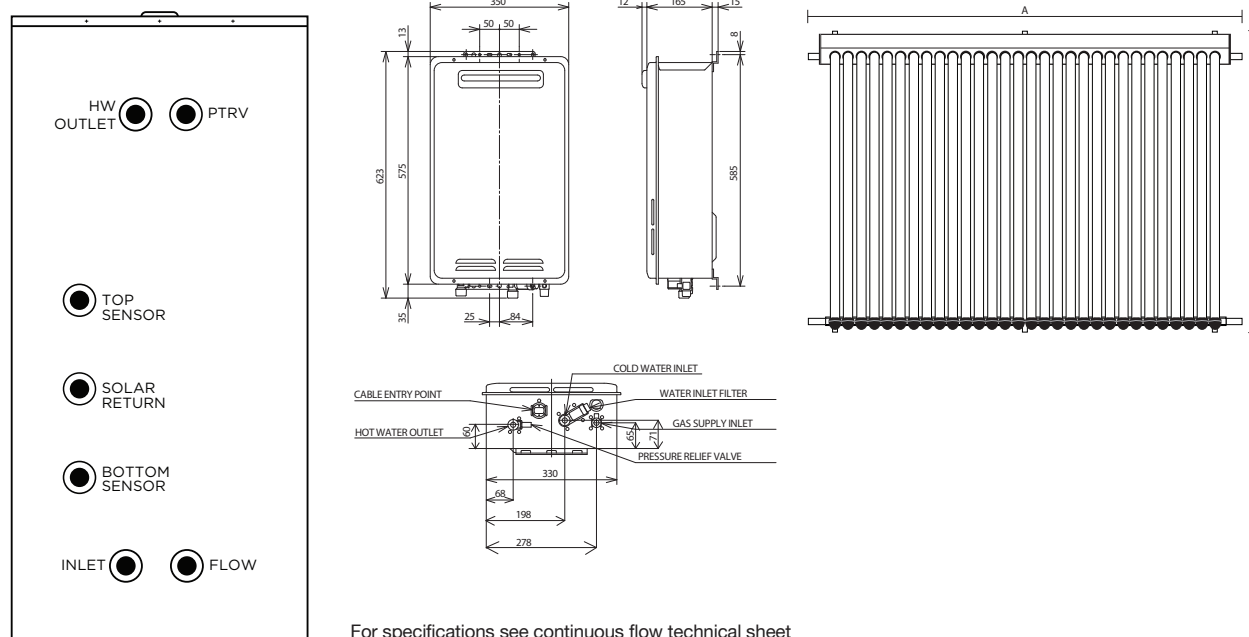

Disclaimer Products in this specification manual must by regulation be installed by licensed and registered tradespeople. The manufacturer/distributor reserves the right to vary specifications or delete models from their range without prior notification. Dimensions and set-outs listed are correct at time of publication however the manufacturer/distributor takes no responsibility for printing errors.

# THERMANN EVACUATED TUBE SOLAR - GAS



## REECE PRODUCT QUALITY GUARANTEE

You have purchased a quality product from Reece Australia Pty Ltd ABN 84 004 097 090 ("Reece"). This product is covered by a 15 year manifold, tubes and framework product warranty and 12 months warranty over parts and labour. The heat exchanger is covered by a 10 year warranty and 3 year warranty over parts and labour.

### 15 YEAR WARRANTY

This warranty covers faults in the product construction, material and assembly. Manifold, tubes and framework which are within 15 years from the date of purchase and tank and heat exchanger which are within 10 years of the date of purchase and, found upon inspection by an authorised Reece representative, to be defective in construction, material or assembly, will be repaired or exchanged with an equivalent product free of charge. Replaced items become Reece's property.

All replacement products will be available for collection without charge to the customer at the nearest Reece branch to the customer's location, or elsewhere as agreed between the customer and Reece.

### Labour and Spare Parts

The labour for the replacement of products and spare parts to which this warranty applies will be supplied by Reece or relevant supplier using licensed plumbers engaged by Reece or relevant supplier within 3 years for heat exchanger and 12 months for manifold, tubes and framework from the date of purchase.

Spare parts which are within 3 years for heat exchanger and 12 months for manifold, tubes and framework from the date of purchase found upon inspection by an authorised Reece representative to be defective in construction, material or assembly, will be replaced free of charge.

### Warranty Conditions

This warranty will apply only under all of the following conditions:

- The item has been installed by a licensed plumber
- The item has been installed for and subjected to domestic residential use only
- Failure is due to a fault in the manufacture of the product
- Proof of purchase (including the date of purchase) is provided
- The installation of the product is in accordance with the instructions provided

This warranty does not cover products purchased as an ex-display without being fully checked and tested for sale by the manufacturer.

### This warranty does not include faults caused by:

- Unsuitable or improper use
- Incorrect installation or installation not in accordance with the instructions provided
- Installation or part installation by the purchaser or any person other than a LICENSED PLUMBER or tradesperson licensed to install this product.
- Normal wear and tear
- Inadequate or complete lack of maintenance
- Chemical, electrochemical or electrical influences
- Harsh detergents or abrasive cleaners used on product finishes

### EXCLUSIONS

To the fullest extent permitted by law, Reece excludes all liability for damage or injury to any person, damage to any property, and any indirect consequential or other loss or damage.

### CLAIM PROCEDURE

For all warranty queries customers are to contact the branch where the product was purchased. These details can be found on your purchase invoice.

Our goods come with guarantees that cannot be excluded under the Australian Consumer Law. You are entitled to a replacement or refund for a major failure and for compensation for any other reasonably foreseeable loss or damage. You are also entitled to have the goods repaired or replaced if the goods fail to be of acceptable quality and the failure does not amount to a major failure.

**Plumbers/Contractors, please ensure a copy of the installation instructions is left with the end user for future reference.**

**Don't risk it, use a licensed plumber. □**

**THERMANN**

**reece**