



Compressor
Voltage Code : FZ

FH5531E

Air Conditioning & Heating (CA)

220 - 240V 1~ 50 Hz

R22

AHC5531EFZ

Conditions	Frequency	Nominal Cooling Capacity		Sound Power ISO3745 / ISO 3743-1
		Watts	BTU/h	
EN12900 / R22	50 Hz	6990	23834	73 dBA

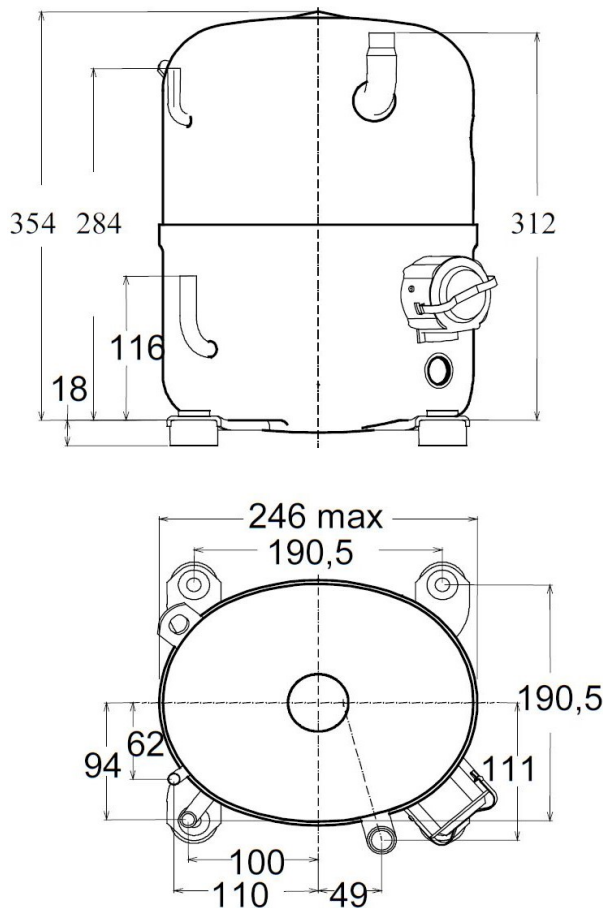

* EN12900 : T°Cond. 50.0°C / T°Evap. 5.0°C / T°Superheat. 10.0°C
T°Subcooling. 0.0K

Certificates :



Displacement (cc)	56.65
Net Weight (Kg)	33.0
Oil Quantity (cc)	1330.0
Oil Type	Mineral
Expansion Device	Capillary_Tube
Cooling	Fan
Main Winding (Ohm)	0.84
Start Winding (Ohm)	3.54
Current	
RLA (A)	14.1
MCC (A)	24
LRA (A)	73
Electrical Equipment	PTCSCR,PSC,CSR
Overload	Interne
Start Capacitor	88 µF / 330 V
Run Capacitor	35 µF / 400 V
Potential Relay	3ARR3*6AS*
Pick Up	180/195V
Drop Out	60/121V
Optional	RVA4G**
PTC	CTP305C2
Resistance	50 Ohms
Refrigerating connection for OD	
Suction Tube	19 (3/4")
Discharge Tube	9.5 (3/8")
Process Tube	6.35 (1/4")

Note : Tecumseh reserves the right to change information contained in this document without notification.



Tecumseh

FH5531E	Tension FZ : 220 - 240V 1~ 50 Hz
----------------	---

Les performances sont données dans les conditions EN12900 :	Surchauffe :	10.0 K
Condition Dew	Sous refroidissement :	0.0 K
The performance data are in EN12900 conditions :	Superheat :	10.0 K
Dew Condition	Subcooling :	0.0 K

50 Hz R22

N°335WG-F

4 T condensation	5 T évaporation	(°C)	-25	-20	-15	-10	-5	0	5	10	15
40	1 P frigorifique	(Watt)				4451	5585	6872	8313	9907	11654
	2 P absorbée	(W)				2121	2291	2443	2577	2692	2789
	3 I absorbée	(A)				10.9	11.6	12.1	12.6	13.1	13.5
50	1 P frigorifique	(Watt)					4593	5724	6990	8390	9925
	2 P absorbée	(W)					2417	2637	2833	3004	3151
	3 I absorbée	(A)					11.9	12.8	13.7	14.4	15.0
60	1 P frigorifique	(Watt)						4613	5714	6931	8263
	2 P absorbée	(W)						2835	3091	3316	3512
	3 I absorbée	(A)						13.6	14.7	15.7	16.6

© 2020 Tecumseh Products Company
All rights reserved

1 = cooling capacity 2 = power input 3 = current 4 = condensing temperature 5 = evaporating temperature

Nota : Tecumseh se réserve le droit de modifier les informations contenues dans ce document sans préavis.

Note : Tecumseh reserves the right to change information contained in this document without notification.