

# MILLI

## EXO HOB SINK SET (4 STAR)

### Important Note

Tap must be installed to the requirements of AS/NZS 3500 by a qualified plumber. The tap seat should have a uniform surface to allow a positive seal between the cartridge and the seat. Tap seats in poor condition must be re-seated.

### INSTALLATION INSTRUCTIONS

#### NOTE:

Always flush out new pipe work prior to installing ceramic cartridge headworks.

This tap is suitable for high pressure applications where both hot and cold water supply pressures are at 150kPa or above.

### FITTING HEADWORKS



#### 1. Measure centre distance of Basin / Bench.

The thickness of the Basin or Bench should be 60mm maximum. For bench tops thicker than 30mm, remove the supplied spacers. (see image 3)

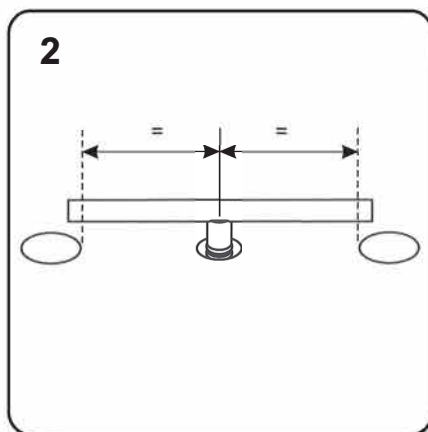

**2. Trim** the Tee-Piece using a pipe cutter to suit the centre distance of the sink tap holes. As a guide, place the tee-piece in the centre of the centre hole and mark the inner edge of the tap holes. Trim at this point.

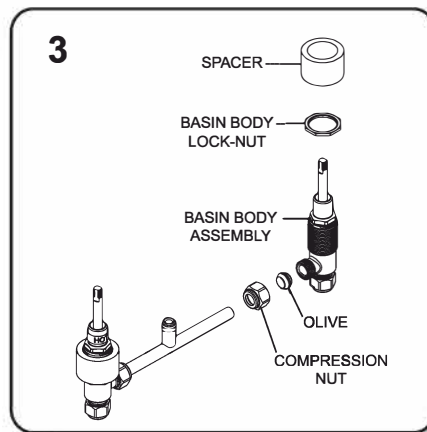

**3. Assemble** - Screw one basin body lock-nut onto each of the basin body assemblies to the bottom of thread. Fit the compression nuts and olives to the tee-piece, then fit the basin body assemblies to this. (Hand tight at this stage) Place the assembly upside down into the sink holes to check centre distances. When correct, torque compression nuts. Place the spacers onto the assembly.

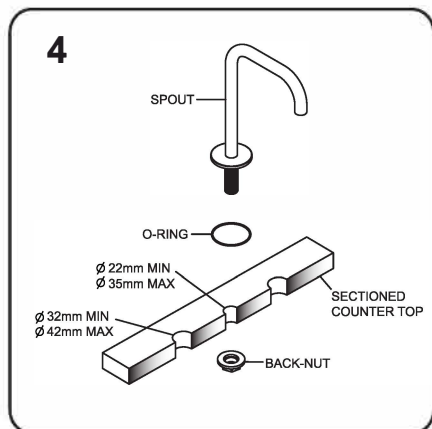

**4. Install the spout** in the centre hole as shown and tighten back-nut until firm. (Spout should't move without significant force)

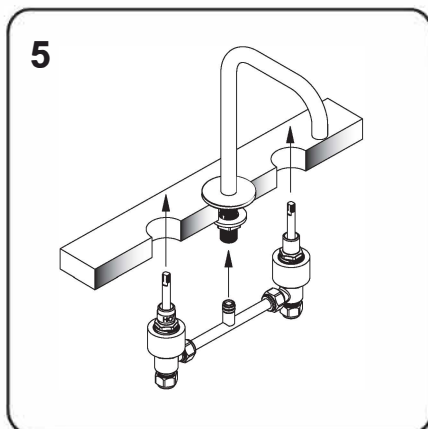

**5. Install the assembled tee-piece** into the basin / bench ensuring the tee-piece o-rings are inserted into the spout.

**TIP - Lightly grease tee-piece o-rings with food grade grease before assembly.**

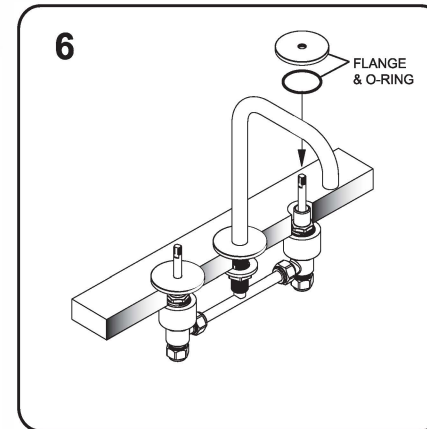

**6. Finish** by carefully pushing the flange and o-ring over the spindles. In a clockwise direction, screw the flange & o-ring onto headworks by hand until the o-ring forms a watertight seal against the sink top.

# MILLI EXO HOB SINK SET (4 STAR)

## HANDLE FITTING

1. Separate parts from Handle as shown.
2. Turn ceramic cartridge spindle to off position.
3. Place the Handle Locking screw over the spindle, slotted side down.
4. Place the O-ring onto the retainer if not already done so, then screw it all the way onto the spindle.
5. Place the Spline adaptor onto the spindle and against the retainer.

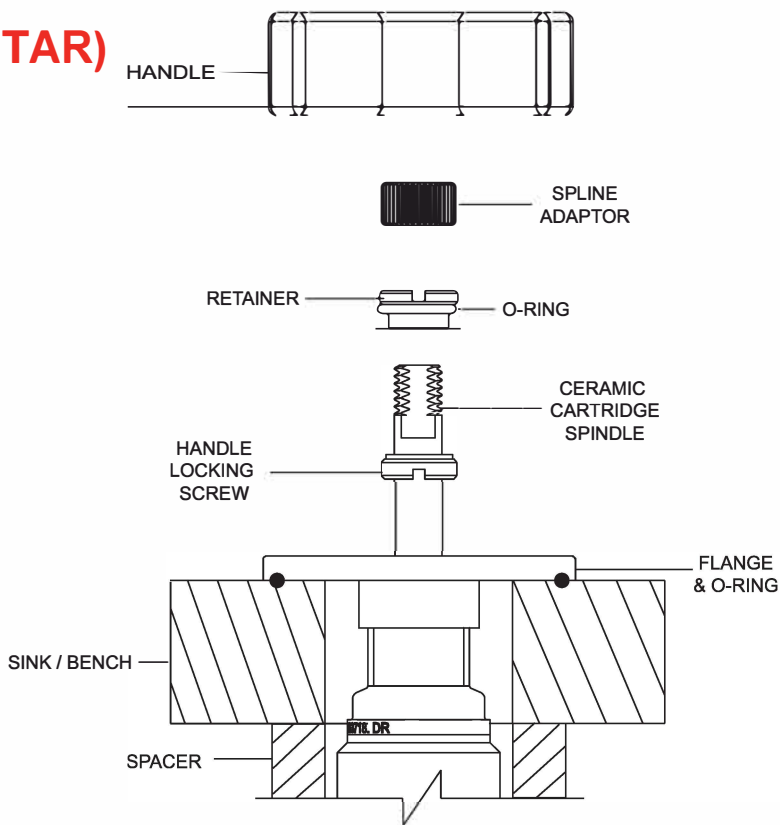

## HANDLE ORIENTATION AND ROTATION

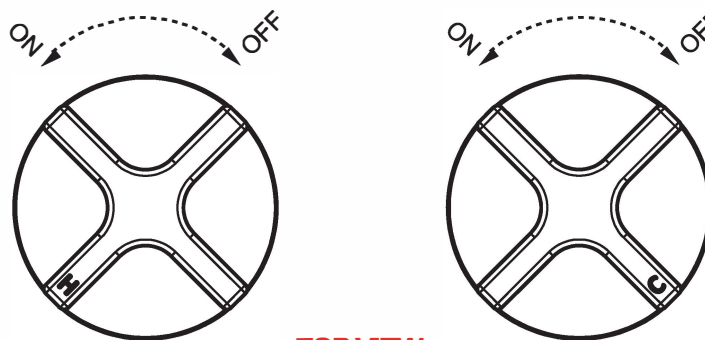

TOP VIEW

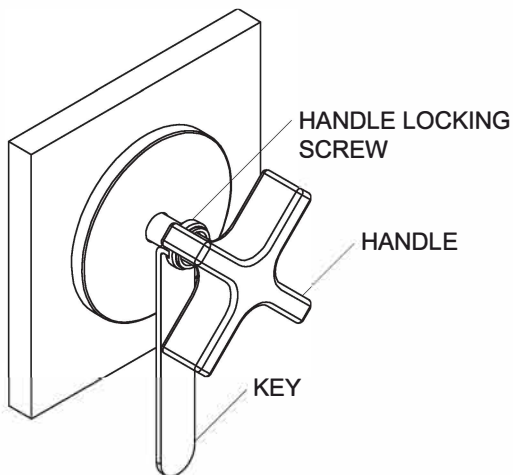

## HANDLE - SECURE FIT

Bring up the Handle Lock Screw and screw into the back of the Handle. Firmly tighten the lock screw using the supplied Key.

**Note:** If the Handle feels loose after installation, remove and ensure the Retainer is on as far as it can go on the spindle.