



Materials & Features

Stainless Steel 90° angled grab rail meets all requirements of the ambulant section of AS1428.1-2009 (amdt 1, 2010) when installed correctly. The snap flange cover conceals the fixings. Unit is ambidextrous and can be mounted on either Left or Right Hand side.

Technical Detail

Rail: 32mm [Dia], 304 Satin Stainless Steel
 Fixings: Included

Available Models

RBA4090-450 Ambulant Grab Rail 90° 450 x 450mm

Related Products

RBA4090-999-001 Single Dress Plate For Panel Mounting
RBA4330-022 Tactile Sign, Male Ambulant, 316 Stainless Steel
RBA4330-023 Tactile Sign, Female Ambulant, 316 Stainless Steel

Installation

Warning: Grab Rails are no stronger than the anchors or walls to which they are attached and, therefore, must be firmly secured in order to support the loads for which they are intended.

Important: Installation instructions and current rough-in details should be furnished with each fixture. Do not rough in without certified dimensions. Dimensions are subject to manufacturer's tolerance of +/-10mm.

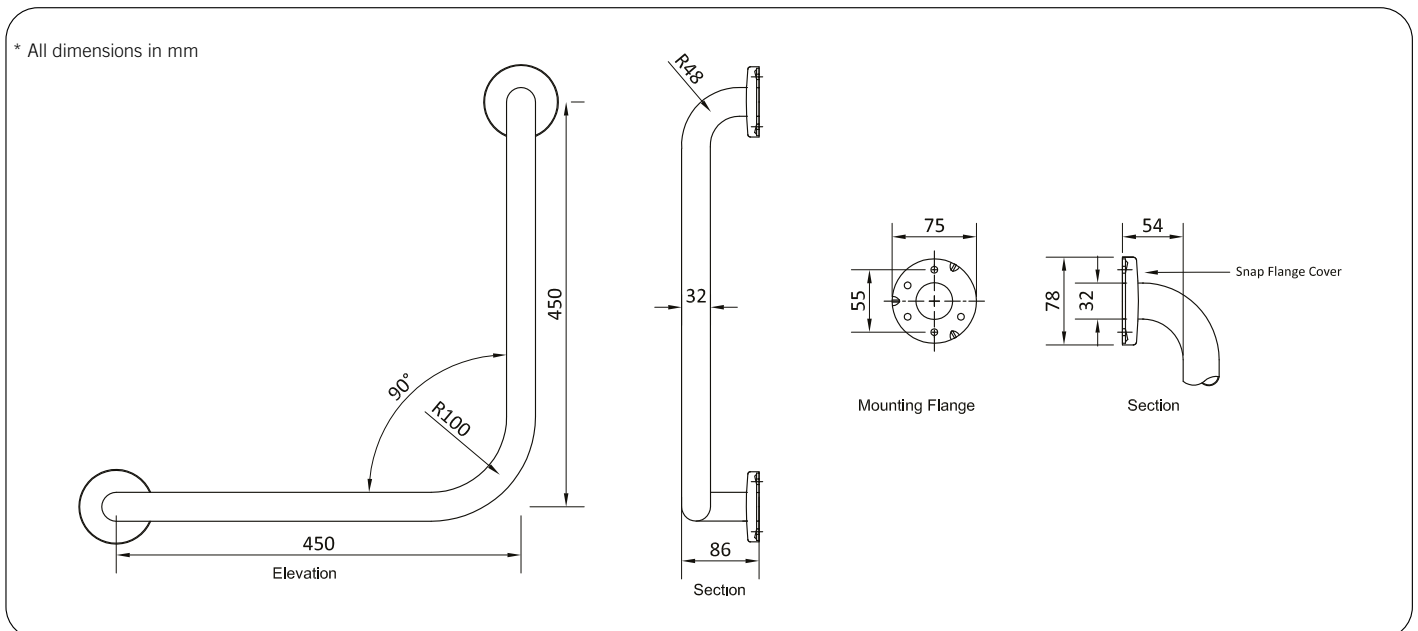

As improvements in the design and performance of RBA products are continuous, specifications may be subject to change without notice. The illustrations and descriptions herein are applicable to production as of the date of this Technical Data Sheet. Revised 12/19 © 2019 by RBA Group TD/Model RBA4090-450/1219