

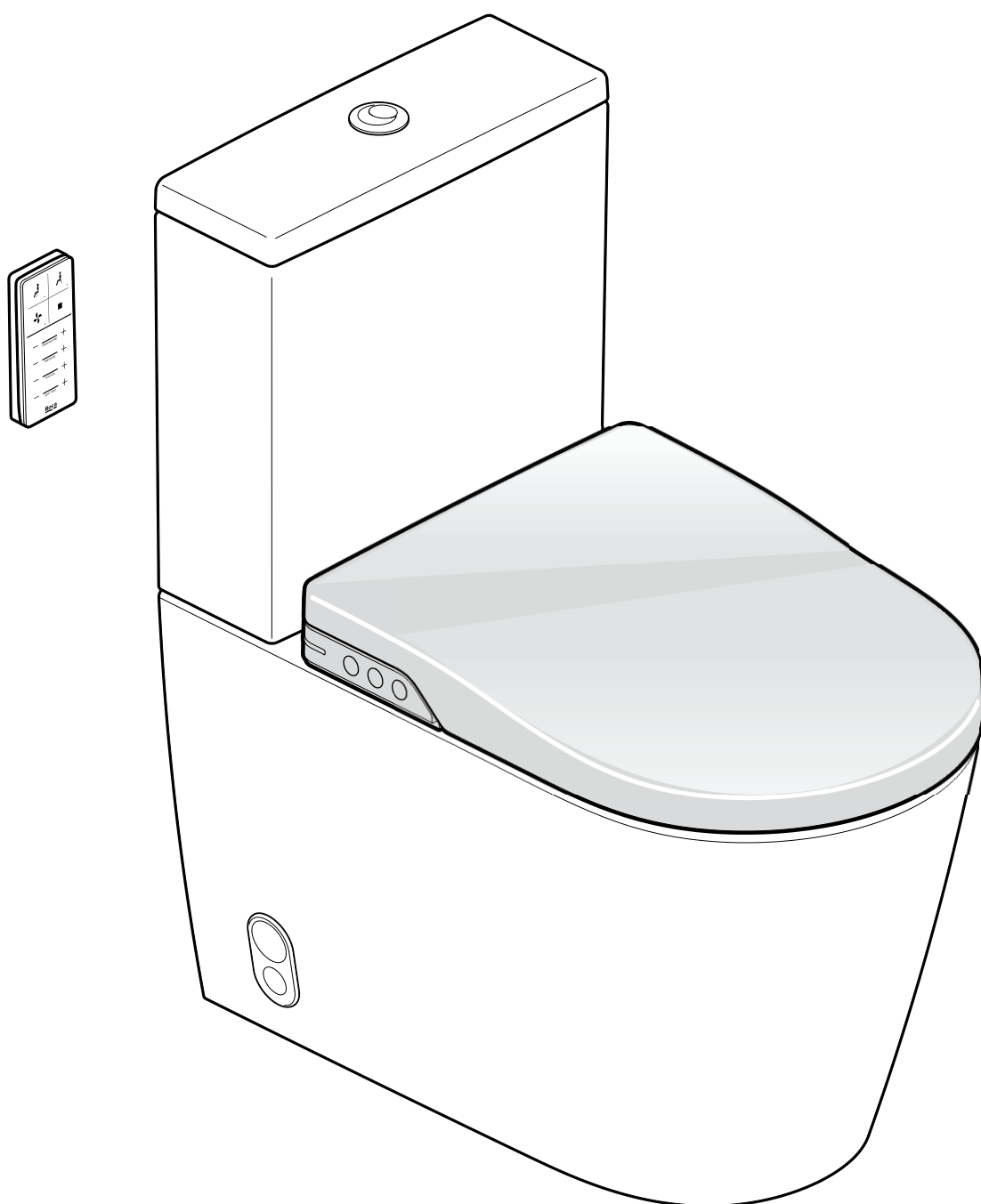

Roca

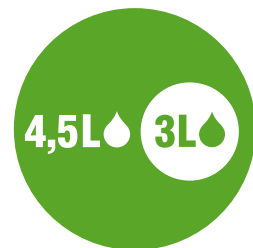

IN-WASH® INSPIRA HS SMART TOILET CC BTW

80307L00R



- Before installation, read this installation manual thoroughly and the included safety precautions. Parts must be installed according to the instructions.
- Rain water or grey water is not suitable to operate this equipment. The **In-Wash** shower toilet may only be operated with normal drinking water.
- Do not damage electrical connection components.
- The recommended water supply pressure is 150 KPa to 500 KPa. Operate equipment within the recommended water pressure.
- Water supply temperature must be between 10 - 30°C. Ensure the correct water temperature is maintained.
- Do not use a water supply hose other than the one provided with this product.
- Make sure that this product is correctly earthed to ground. (If the product is not earth-connected, there is a risk of electric shock).
- **Dual check valve must be fitted before cistern stop.**
- **Please note that this product has an Integral High Hazard Backflow Prevention device that meets the requirements outlined in AS/NZS 3500.**

Technical information	
Power Supply	240V / 50Hz.
Power Wattage	1700 W
IP Rating	IPX 4
Note: Any electrical work connected on this project must be installed by qualified personnel, in accordance with AS/NZS 3000 Wiring Rules.	
Certification	
Watermark	AS1172.1/AS1172.2 Certificate No. WMKA02321
WELS	4 Star, 4.5/3 litre, Average Flush 3.3 litre
RCM	

 WARNING	
<p>KEEP OUT OF REACH OF CHILDREN This product contains button / coin cell batteries. Keep new and used batteries away from children. A swallowed button or coin cell battery can cause internal chemical burns and death in as little as two hours. Dispose of unused batteries immediately. If you think batteries might have been swallowed or placed inside any part of the body, seek immediate medical attention.</p>	

'WARNING' This product includes a button/coin battery and can cause serious injuries if it is swallowed or placed inside any part of the body. Immediately call the 24-hour Poisons Information Centre on 13 11 26 (Australia) or National Poisons Centre on 0800 764 766 (New Zealand) for fast, expert advice.

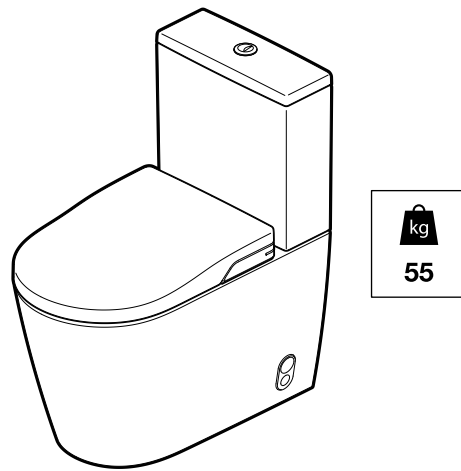
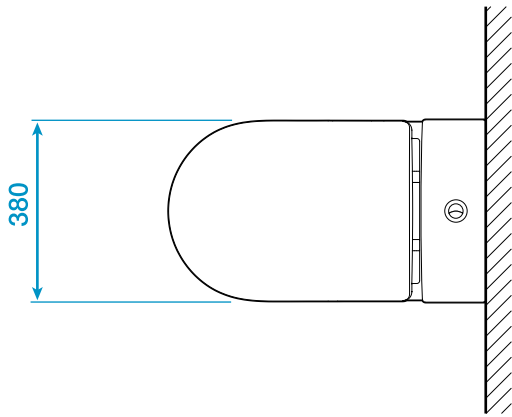
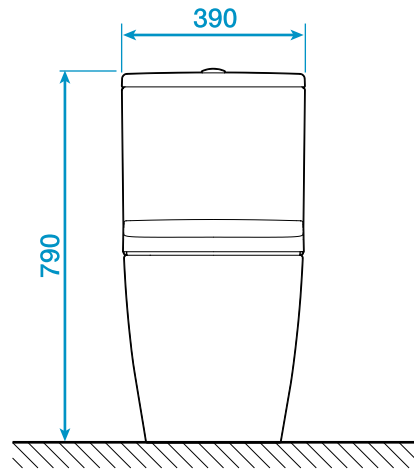
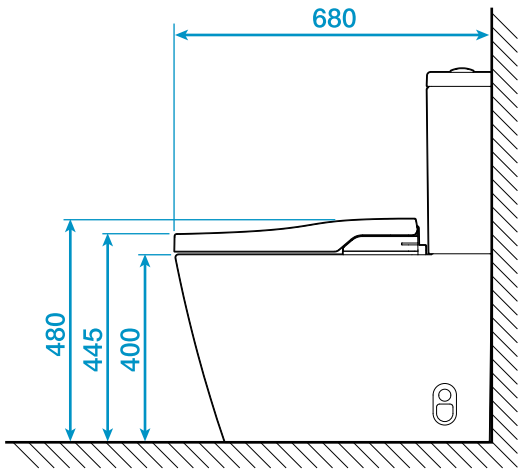

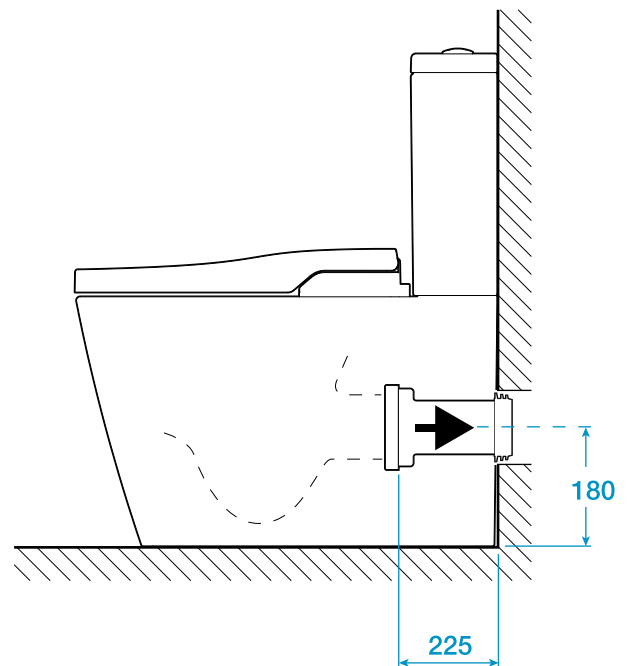
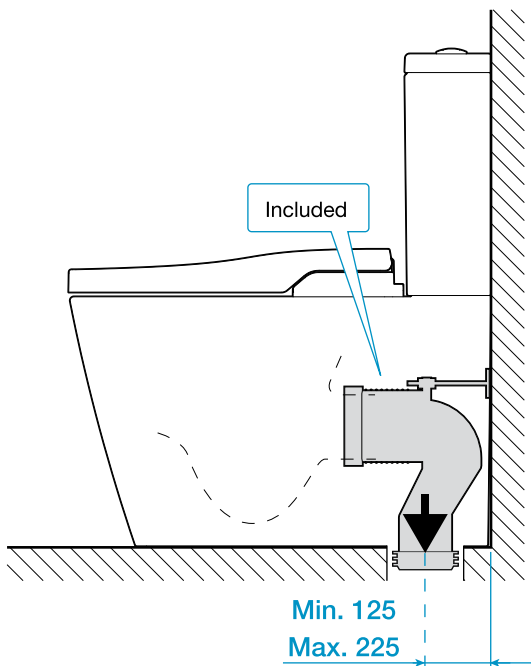

Alternative drainage connections

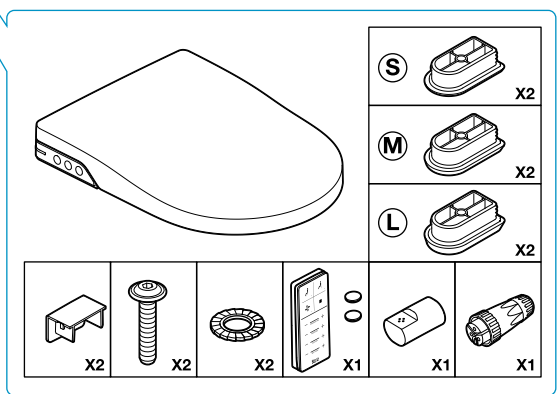
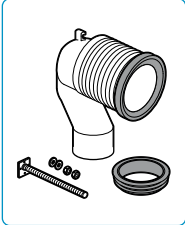
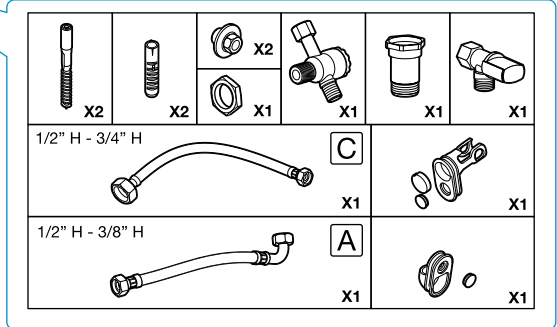
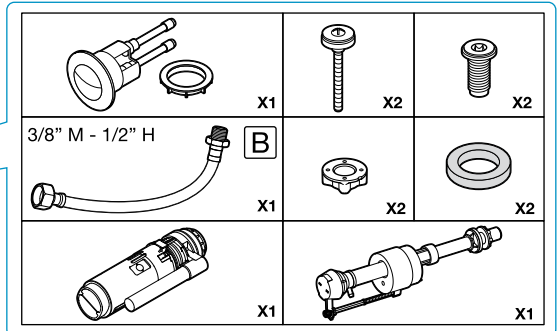
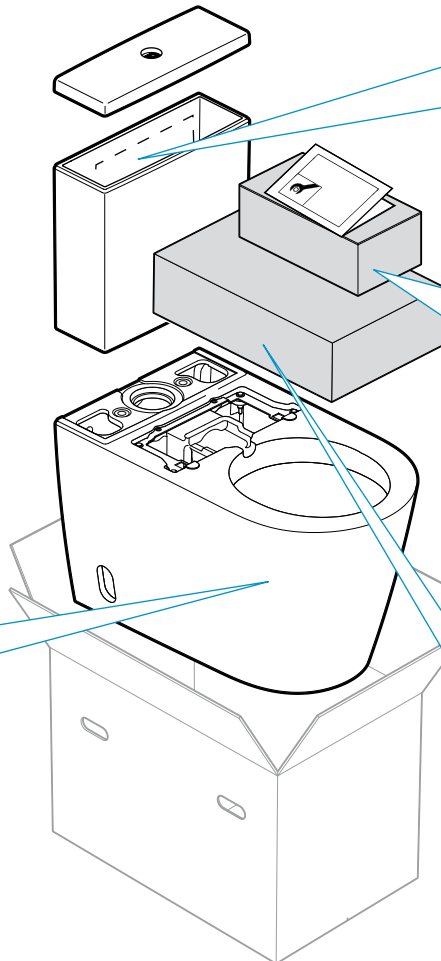
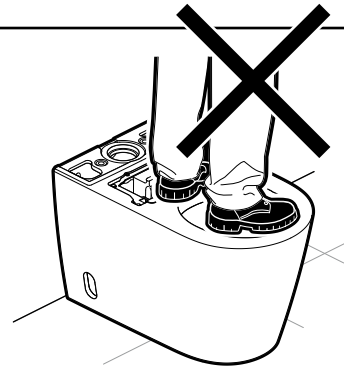
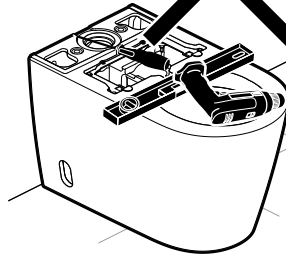
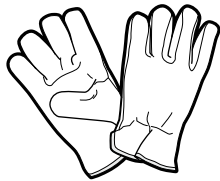
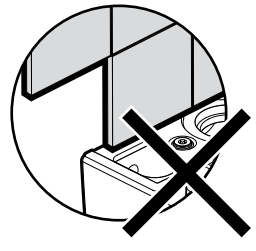
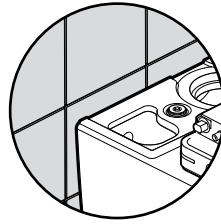
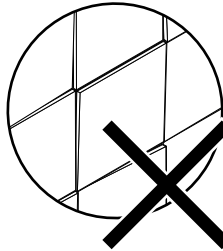
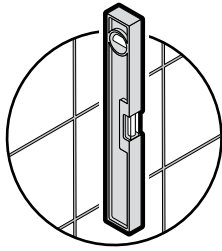
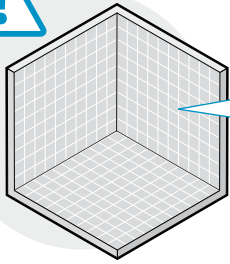



1 Pipes

 Do not use rain water.
Use only potable water. 

Option **1a**

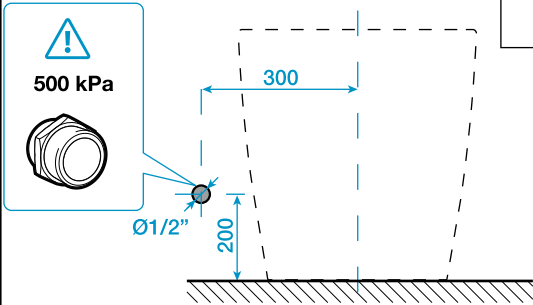

Option **1b**

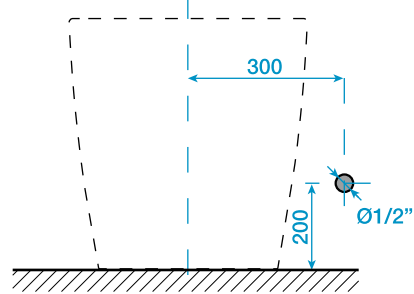

2 Electrical

Option **2a**

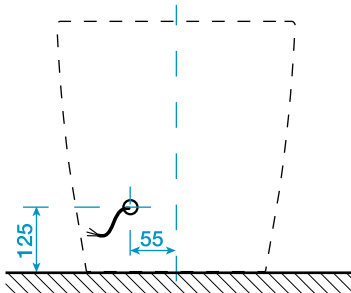

Option **2b**

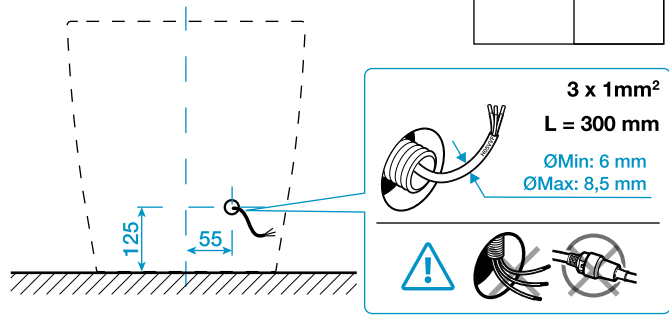

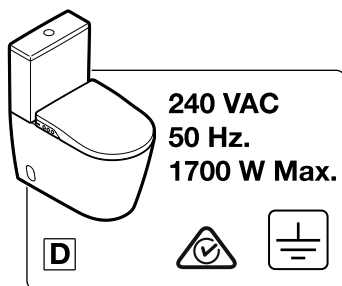
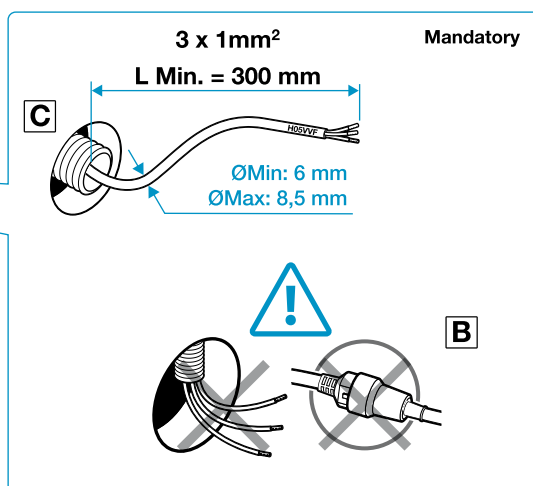
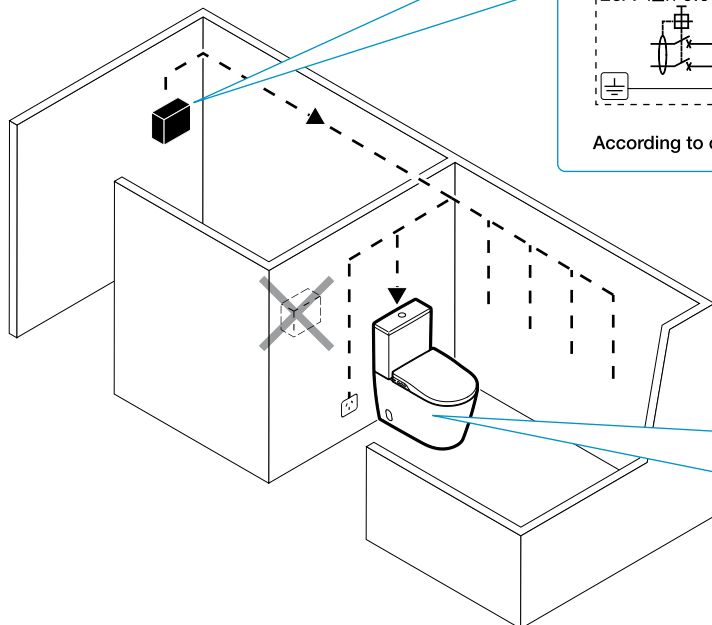
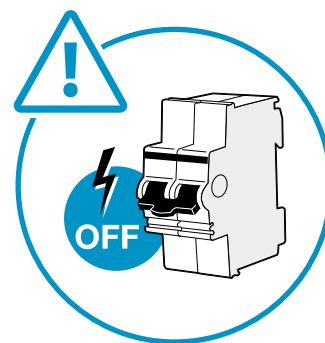
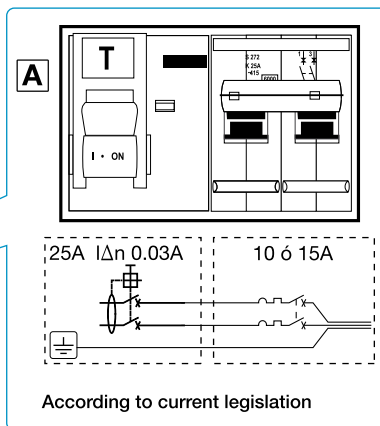
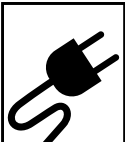

A The electrical installation must be protected by means of a IDn 0,03A and 25A differential switch and a magnetothermal switch of 10 or 15A. Both switches must be placed outside the bathroom.

B A fixed power connection must be connected by a dedicated flexible power cable consisting of 3 wires (active, neutral, earth) of at least 1mm². The connection must be done inside an IPX4 or better junction box. If it is necessary to replace the power cable, this must be done by qualified service staff.

C 240V, 50Hz.

- Any electrical work conducted on this product must be installed only by qualified personnel, in accordance with AS/NZS 3000 Wiring Rules.

Note - Please consult with a qualified electrician to confirm an appropriate installation location.

- No additional electrical equipment should be fitted inside the toilet.

- This product (IPX4) shall not be exposed to water jets for cleaning purposes.



1

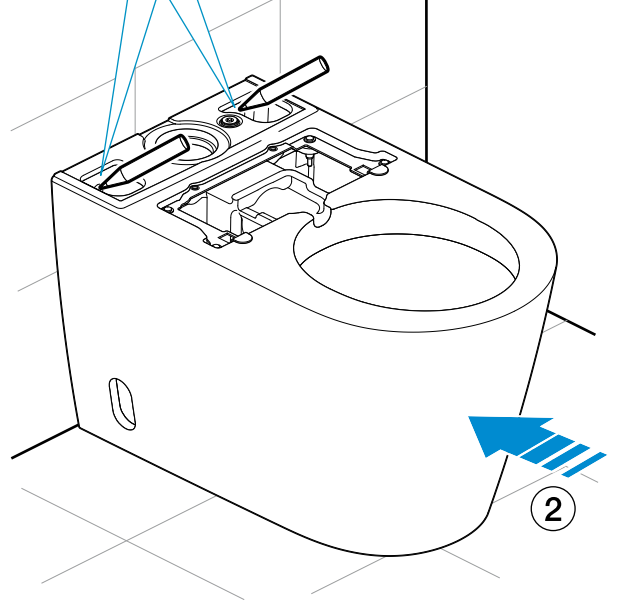
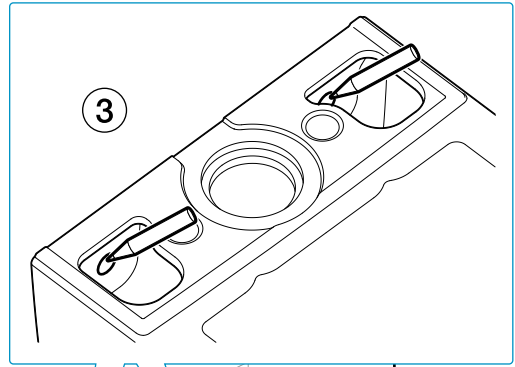
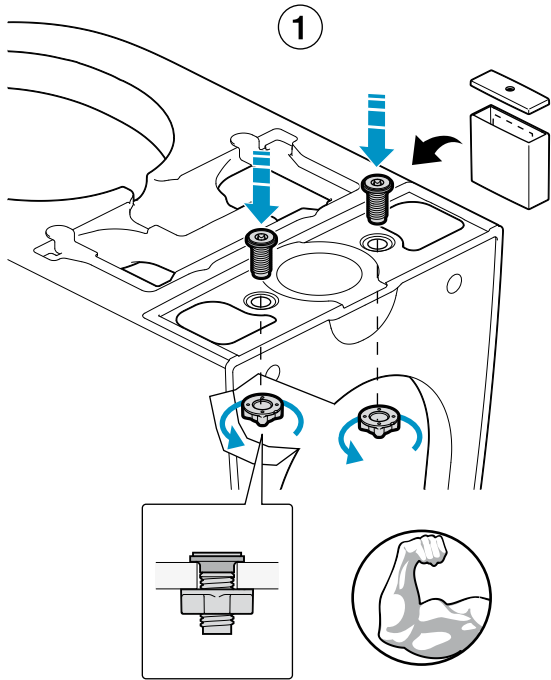

2

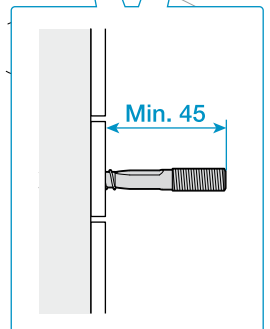
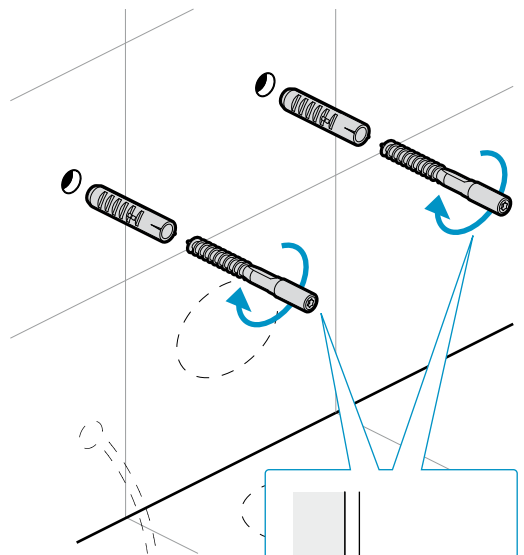
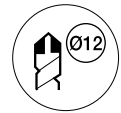
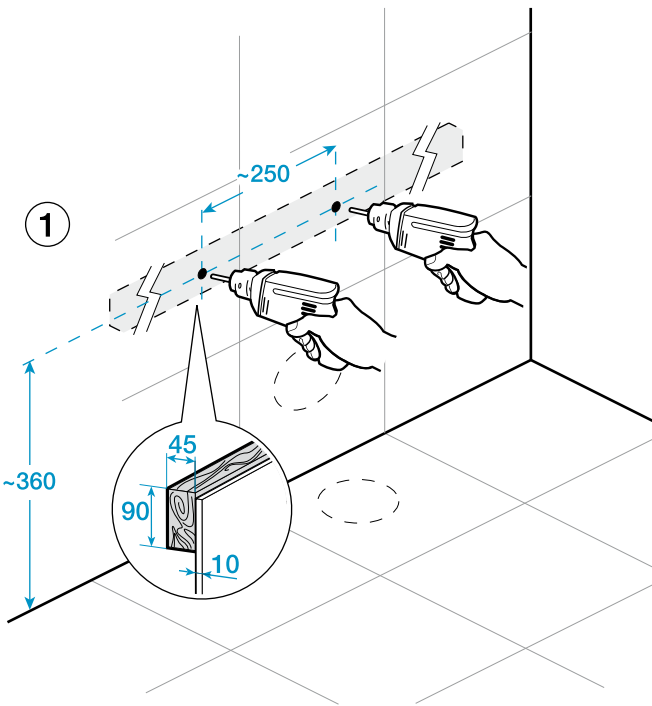

3

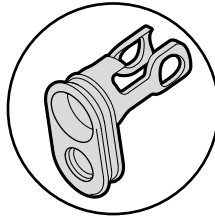

Water filter support

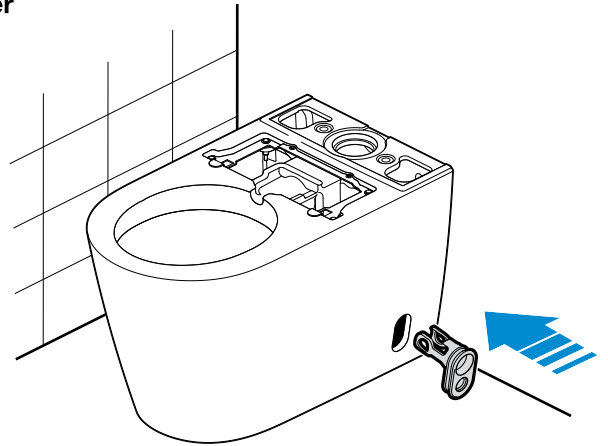
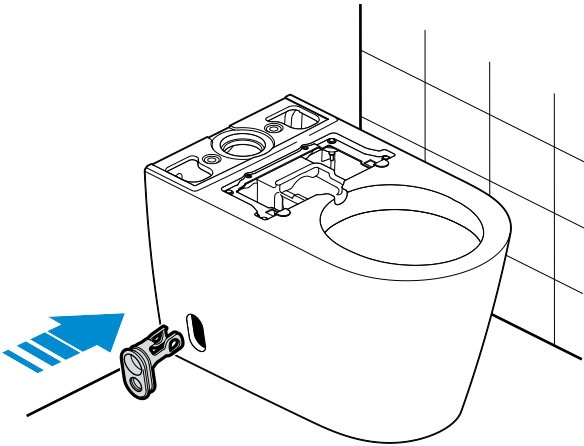

Install the water filter on the most accessible side

4

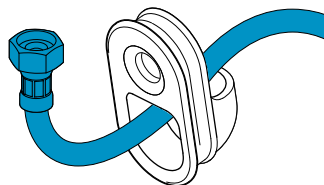
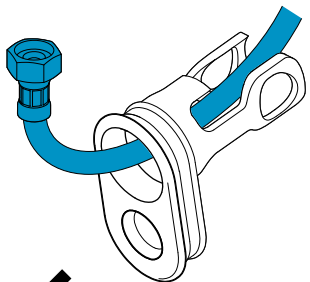
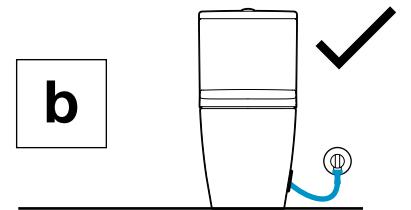
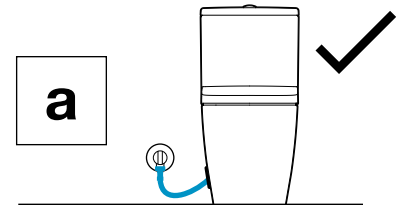
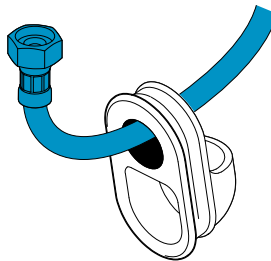
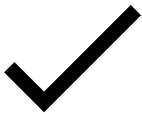
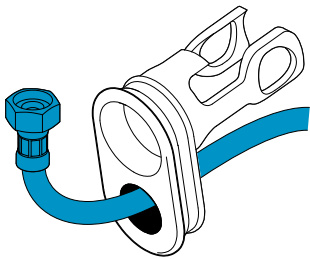

5

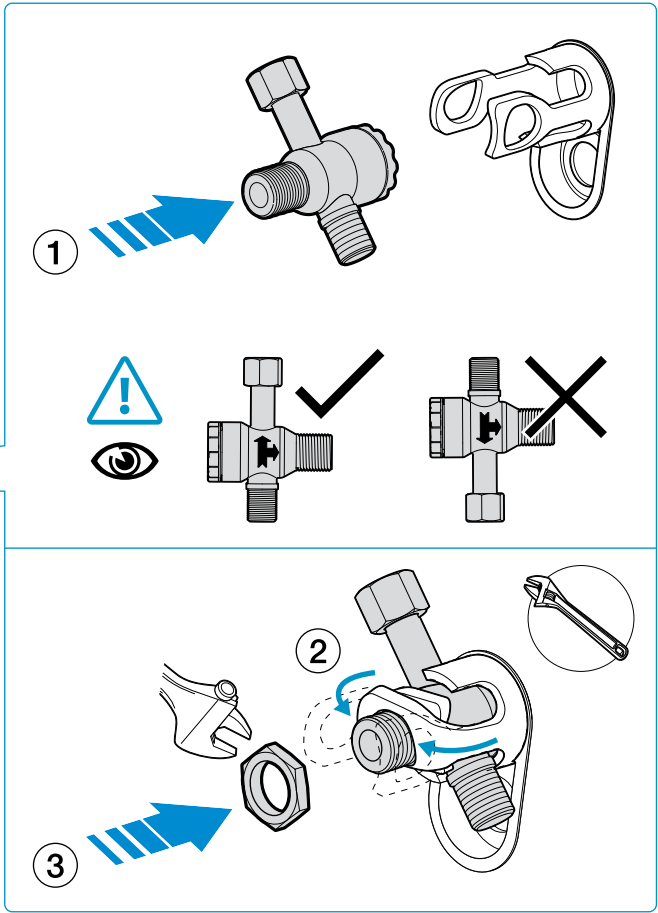
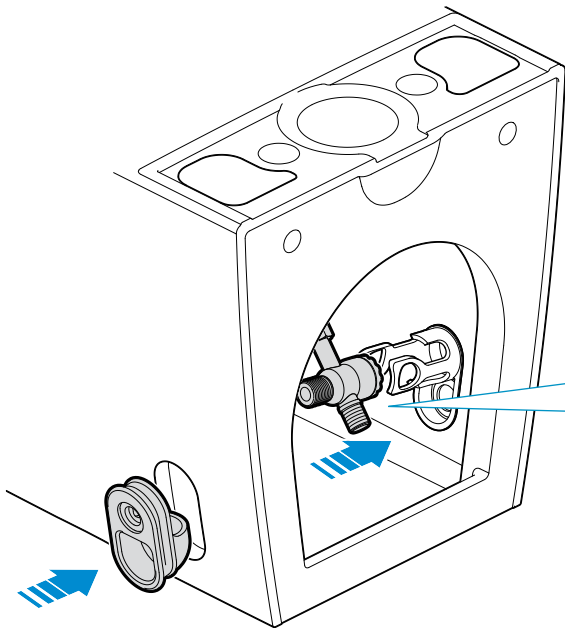

6

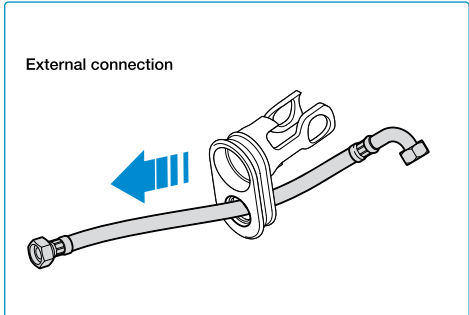
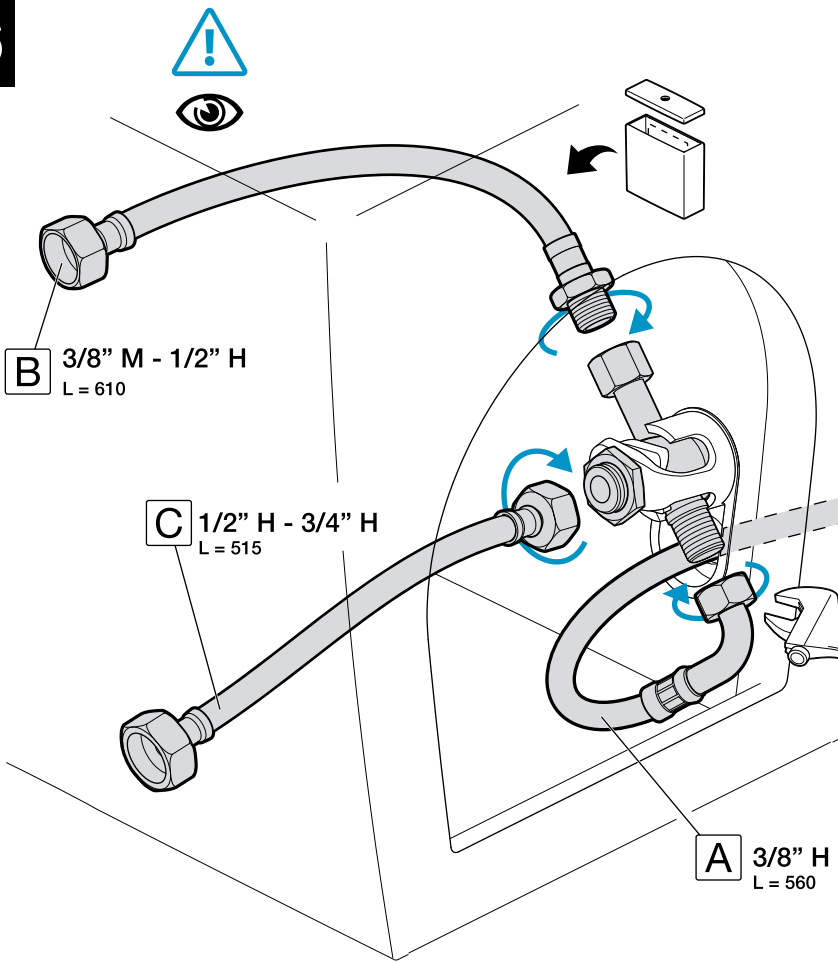

B 3/8" M - 1/2" H
L = 610

C 1/2" H - 3/4" H
L = 515

A 3/8" H - 1/2" H
L = 560

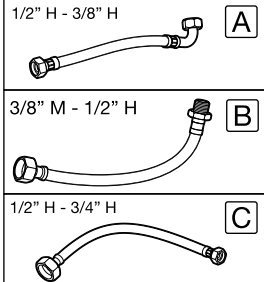

7

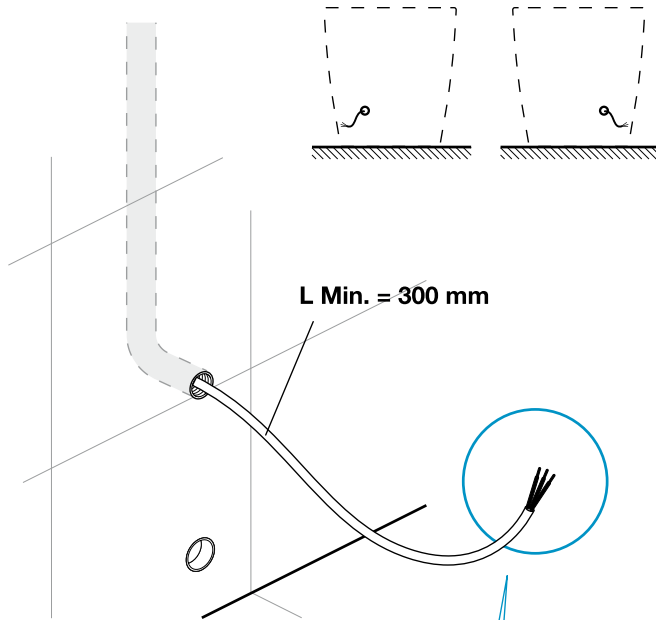

1

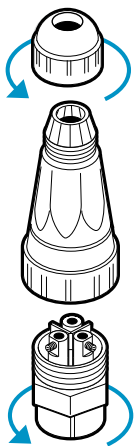

2

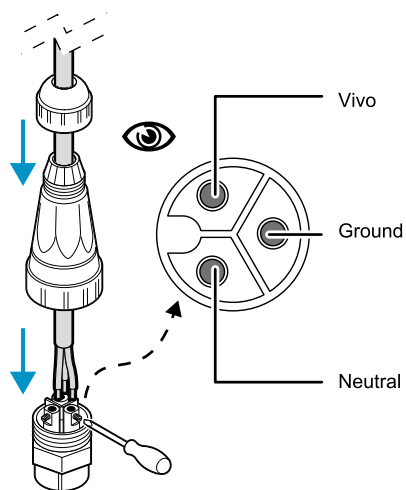

3

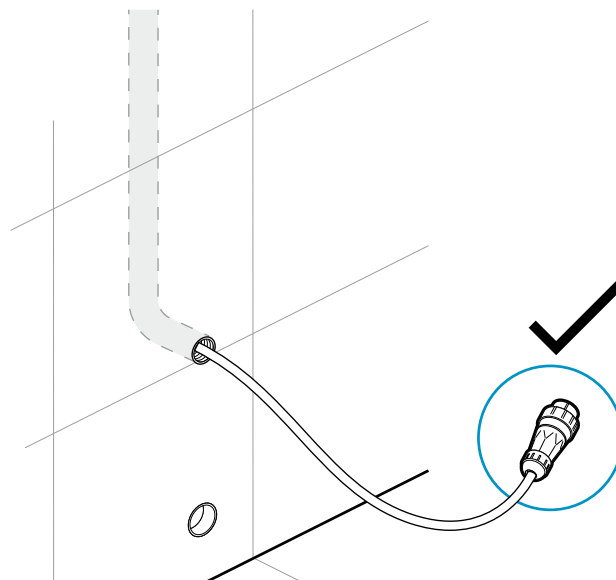
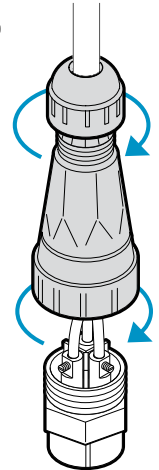

8

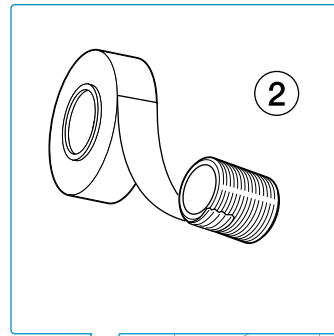
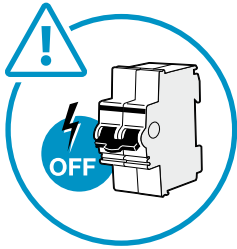

1

Option
1a
2a

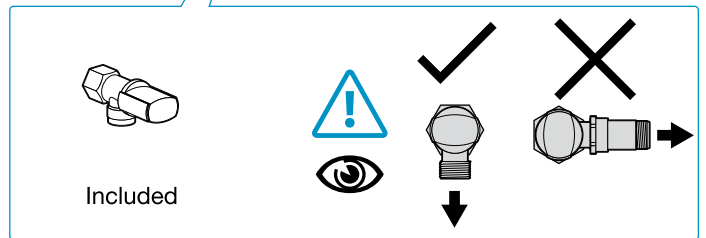
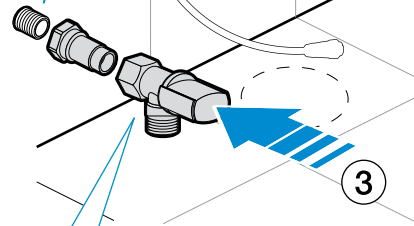

Note: **Dual check valve must be fitted before cistern stop.**

9

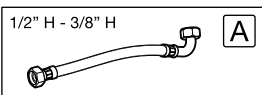
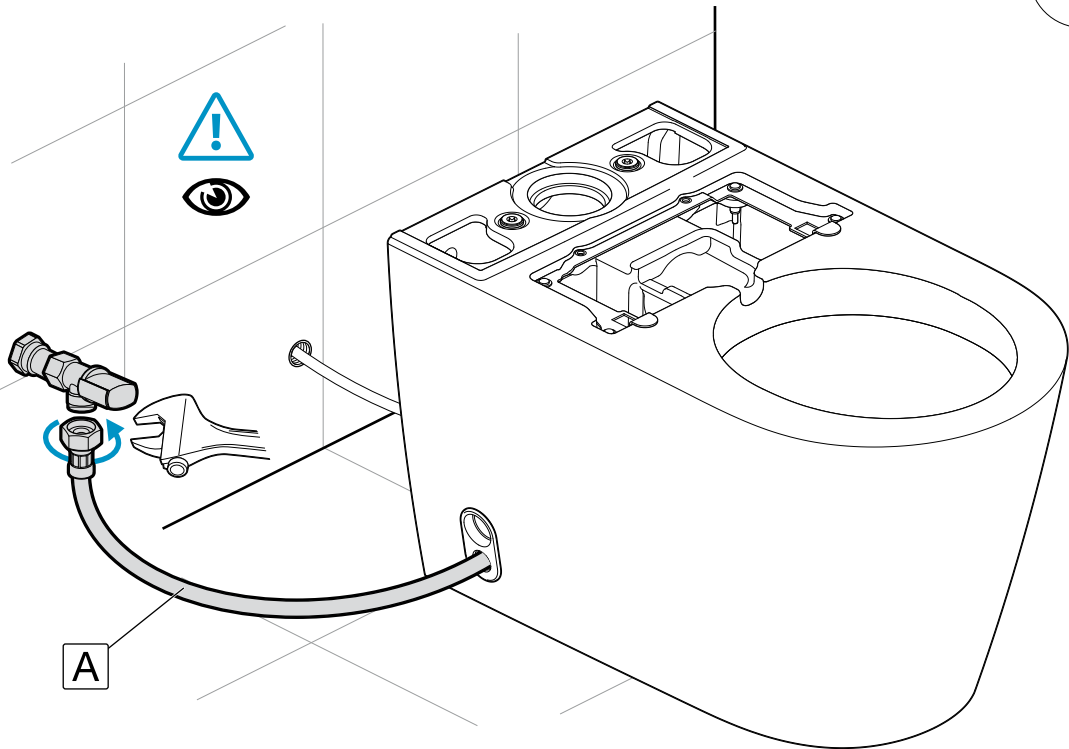

10

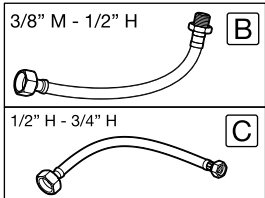
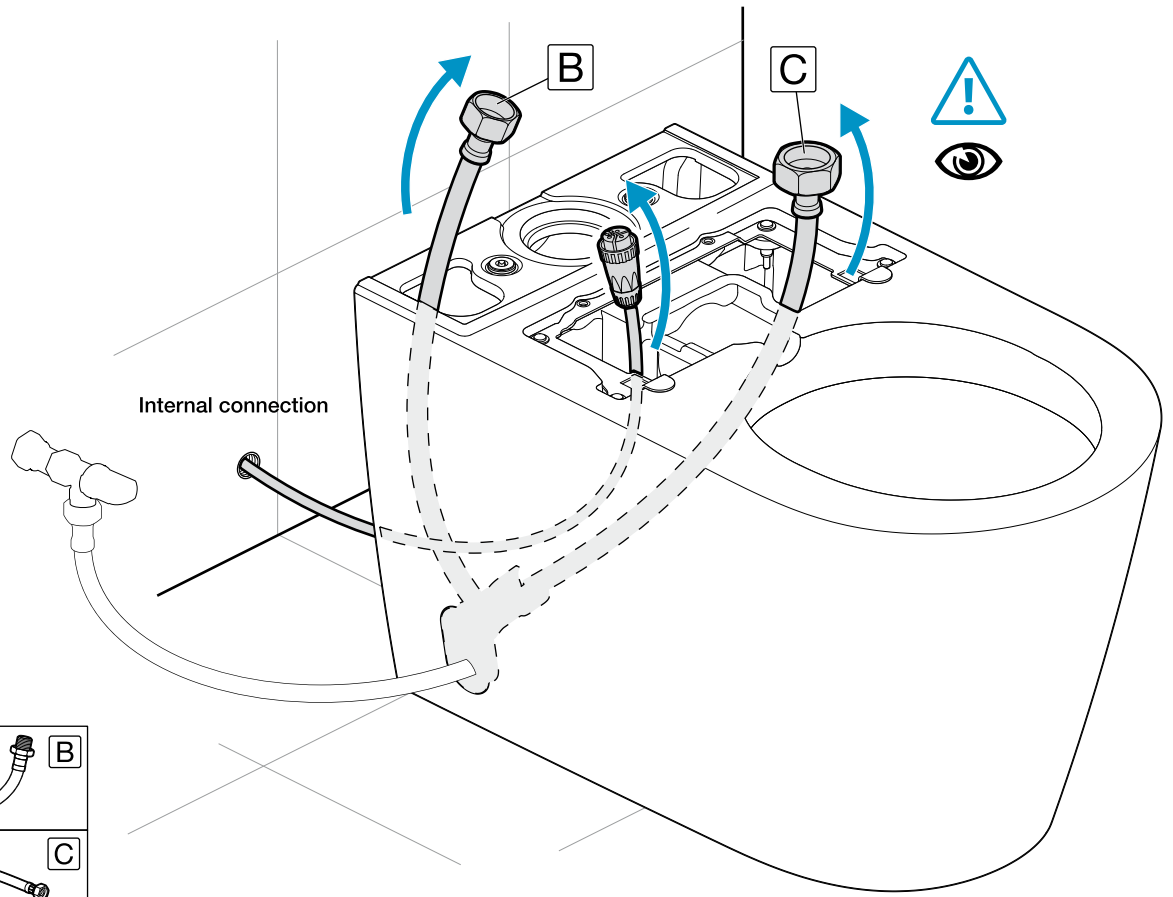

11

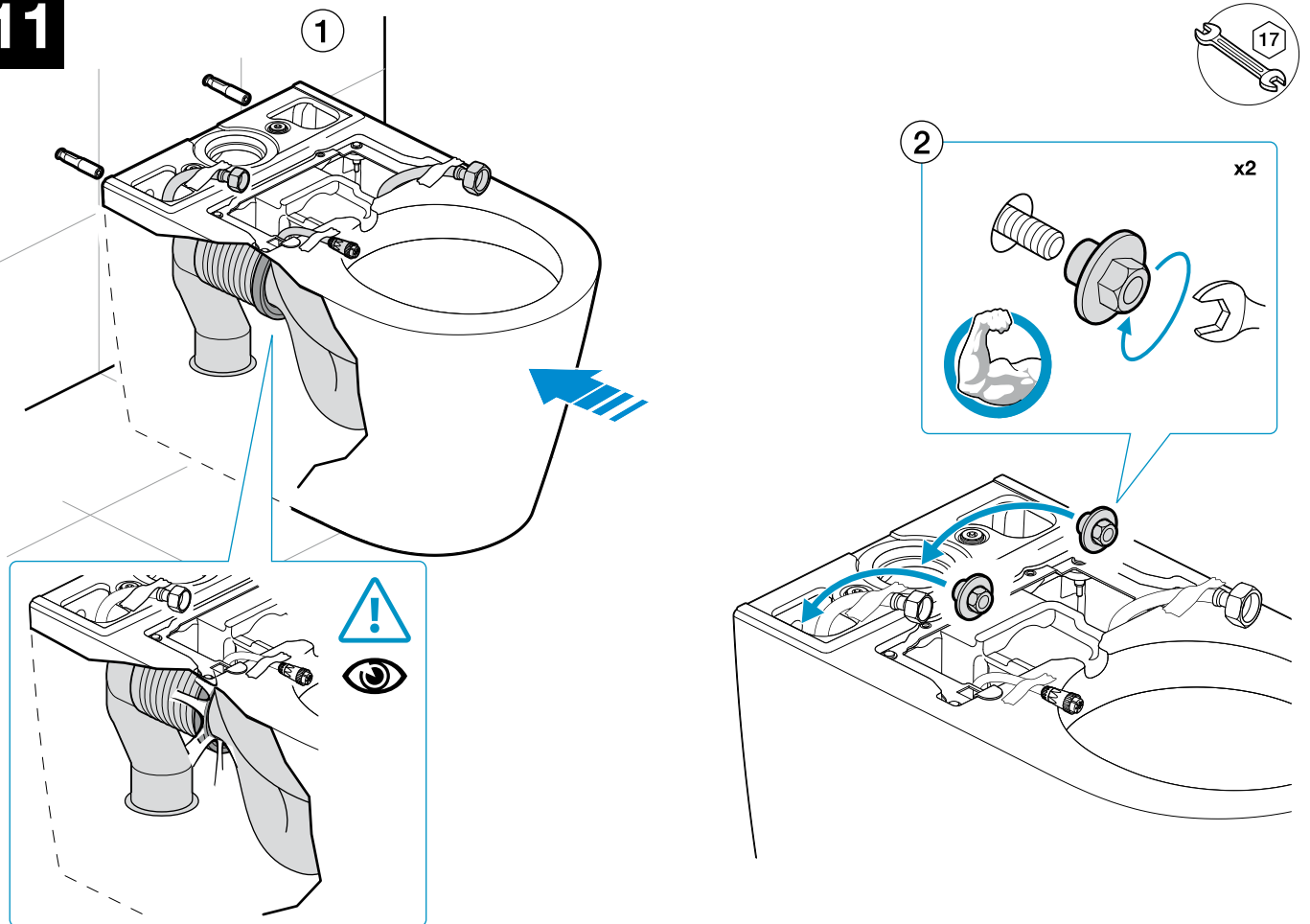

12

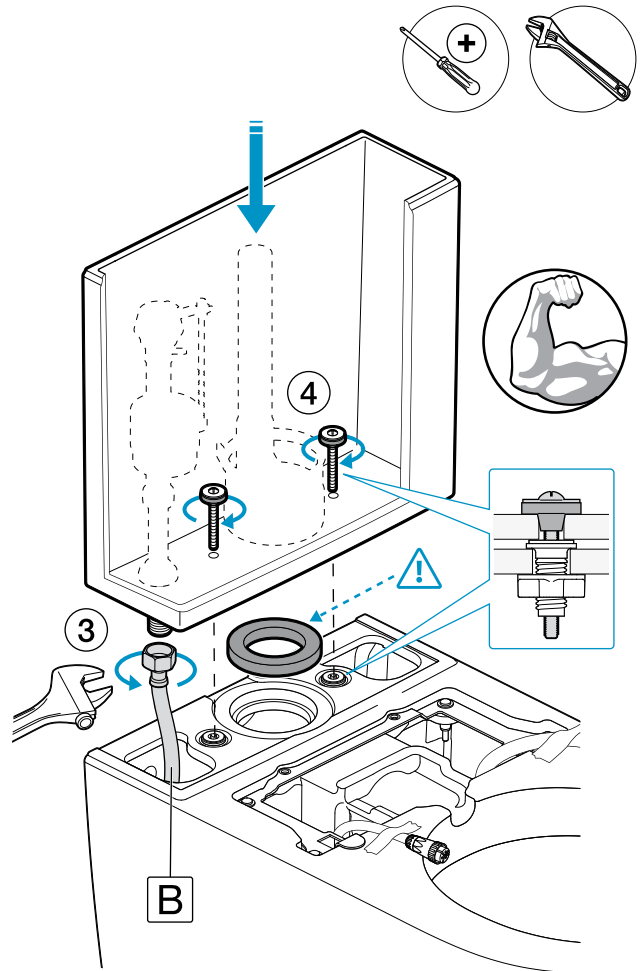
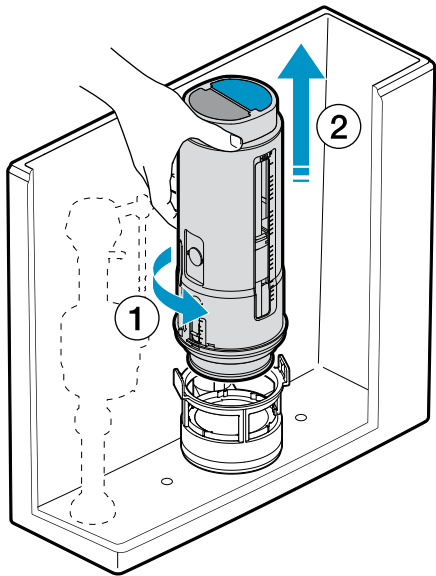

13

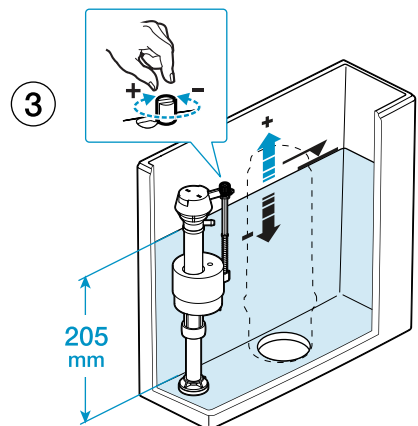
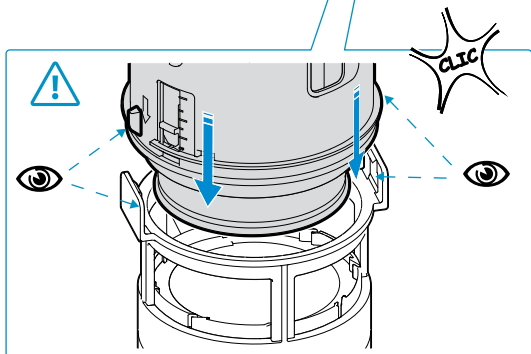
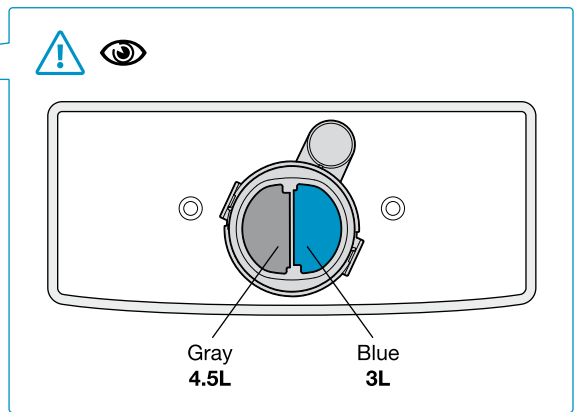
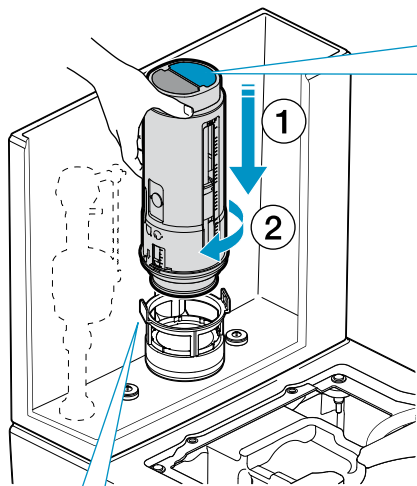

14

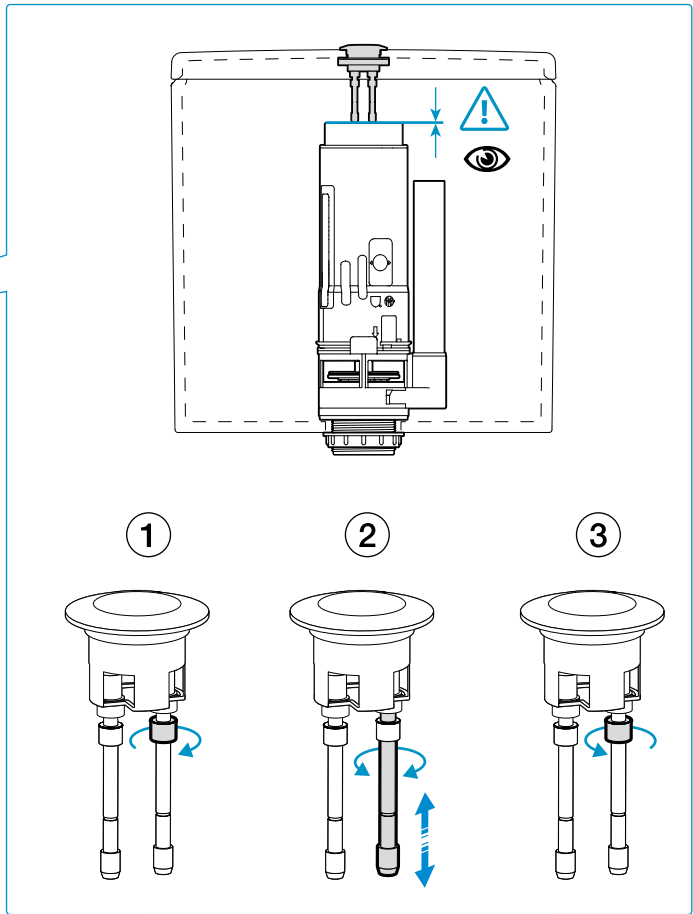
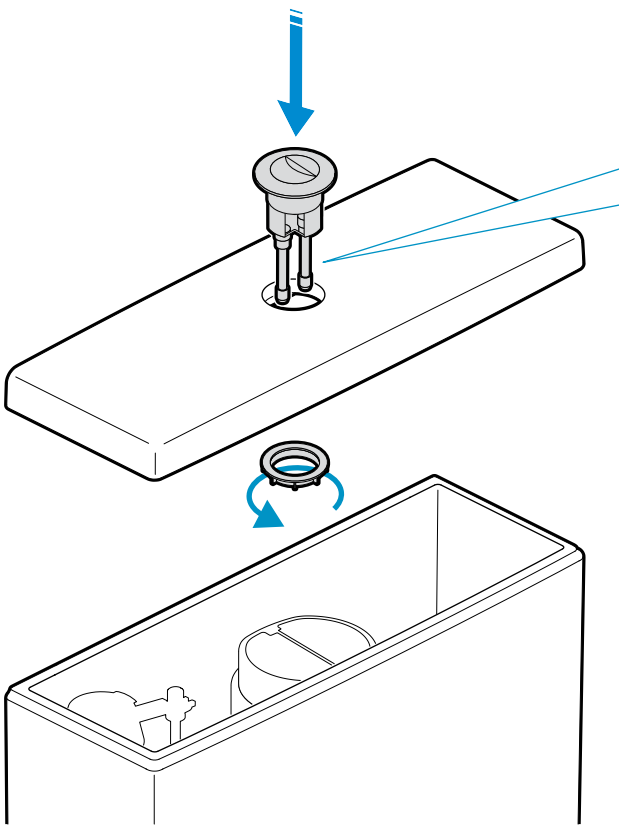

15

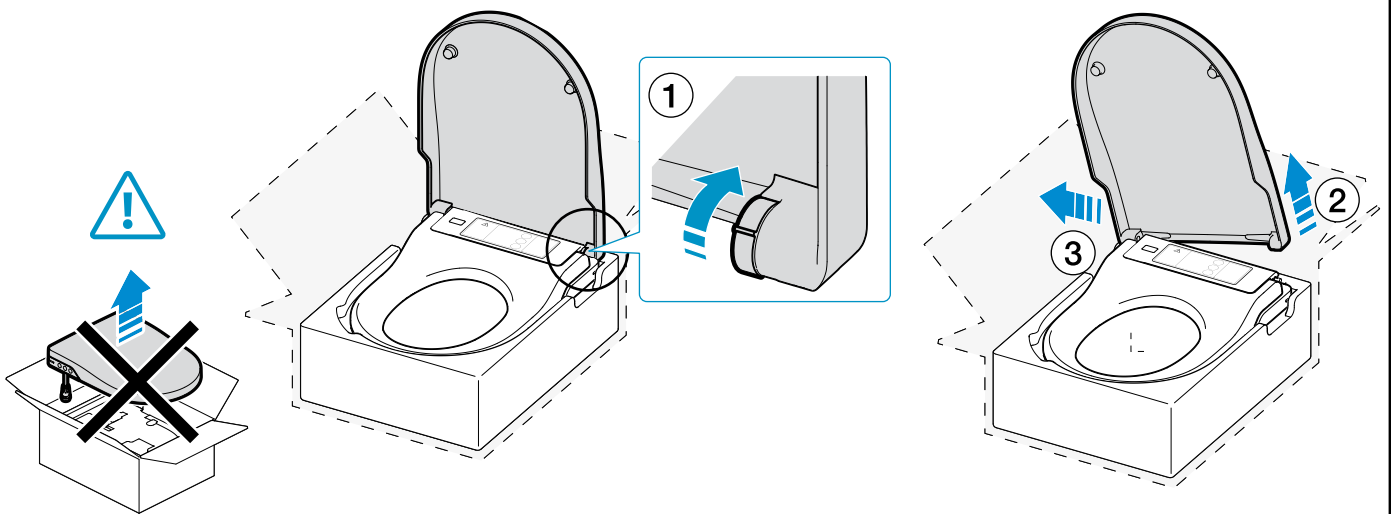

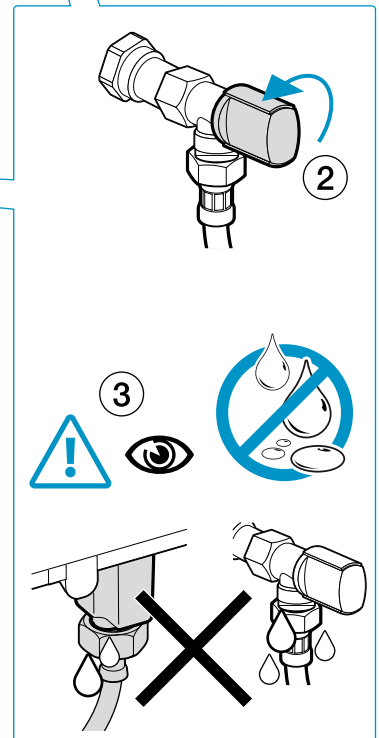
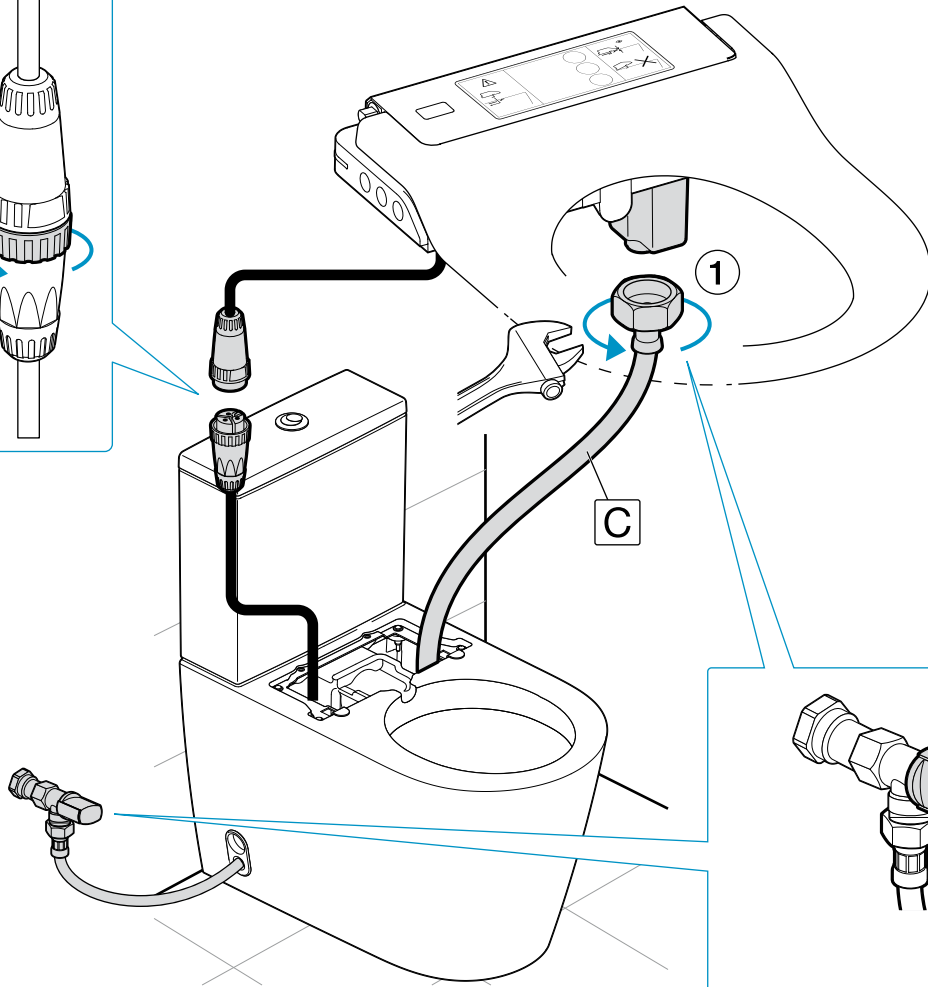
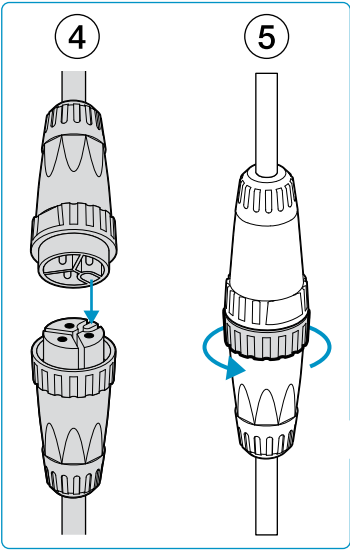

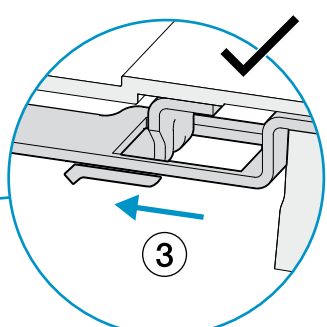
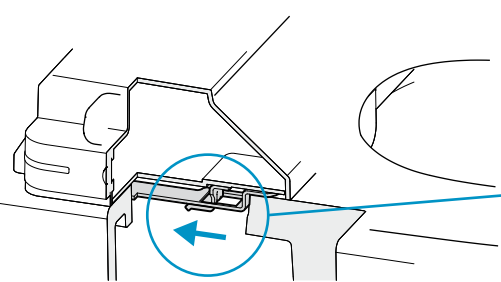
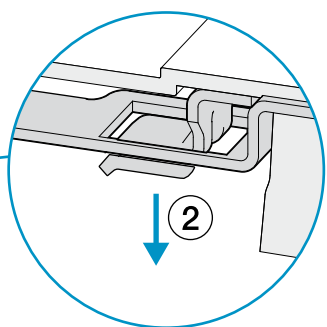
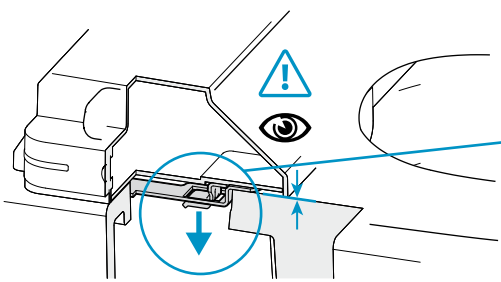
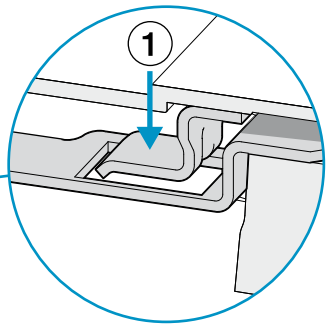
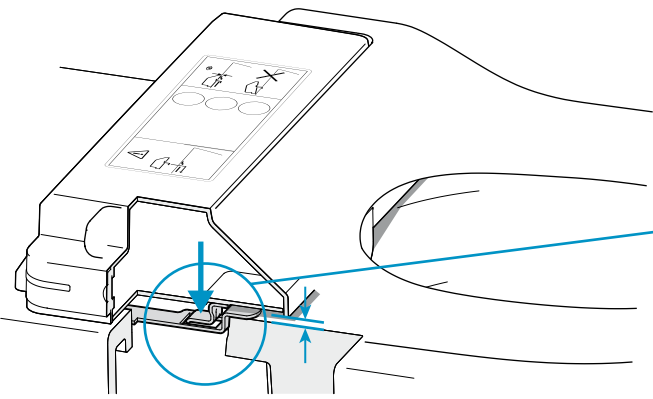
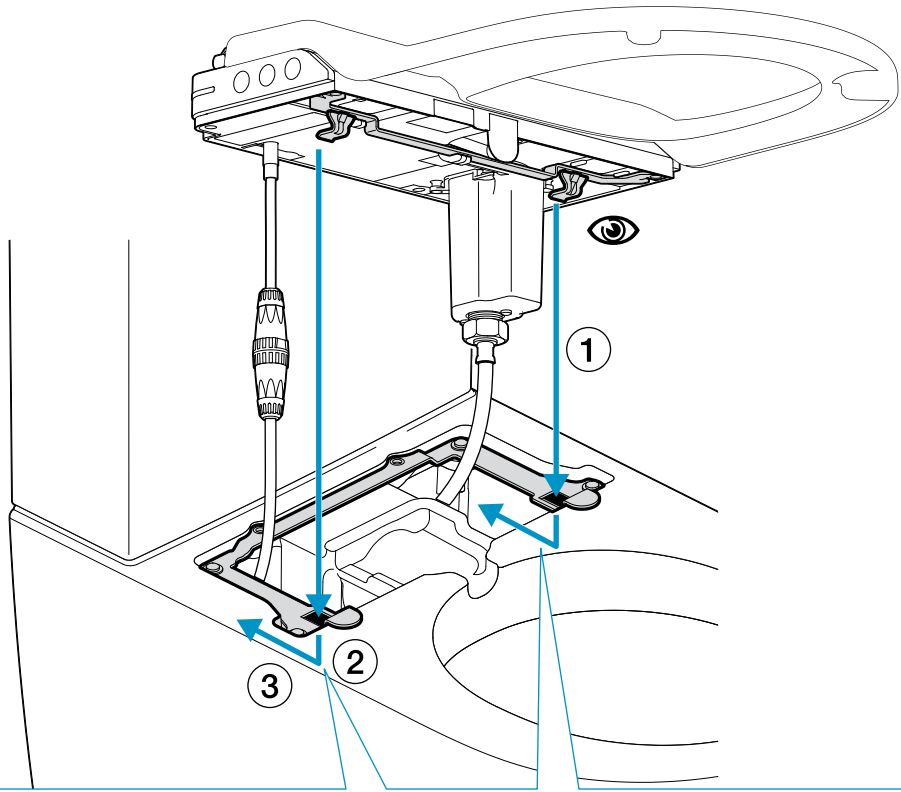

18

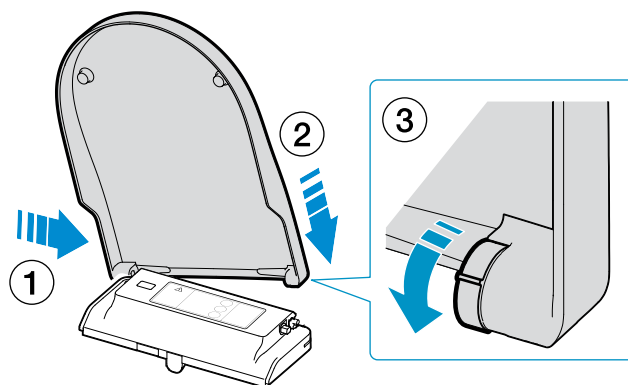
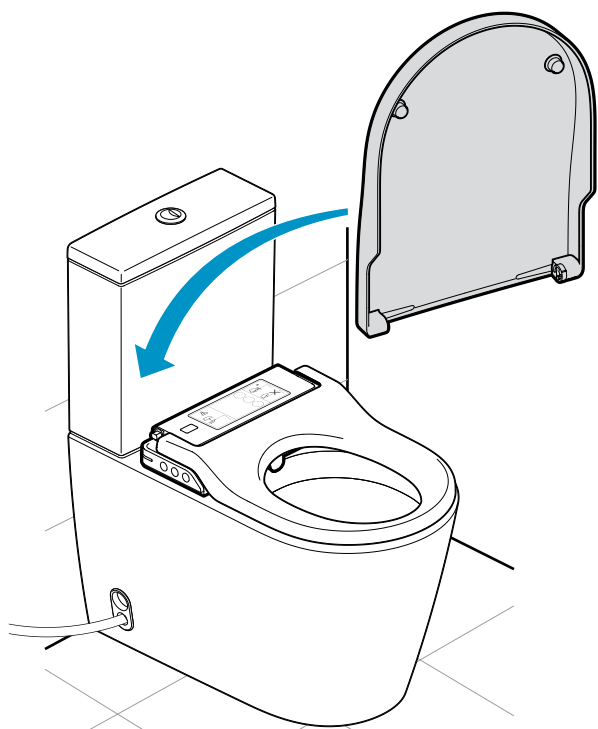

19

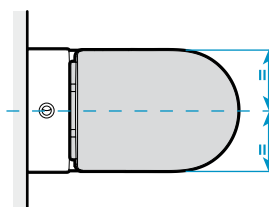
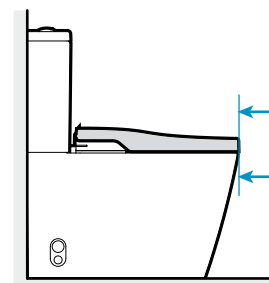
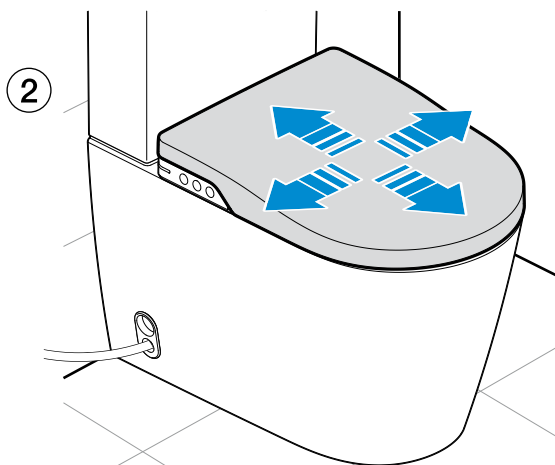
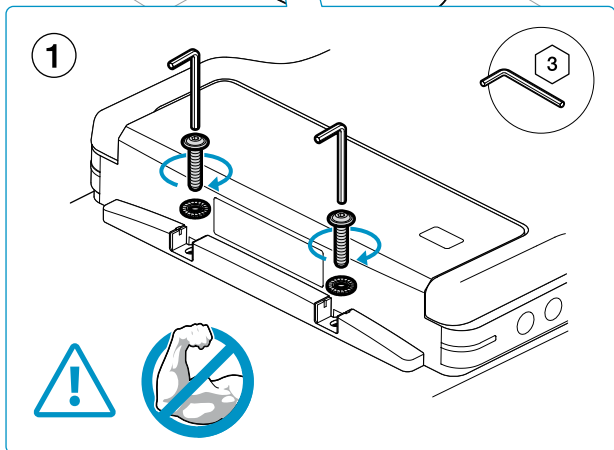
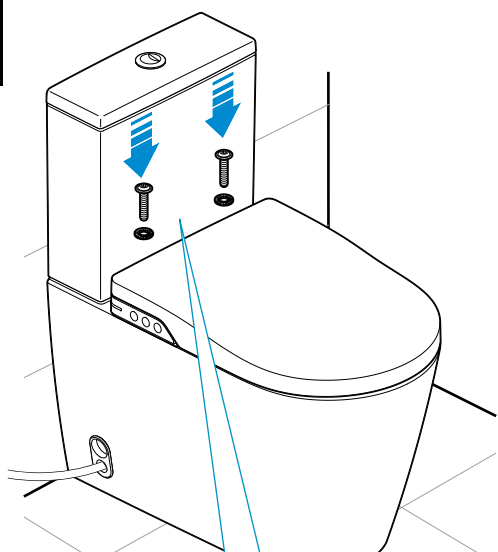

20

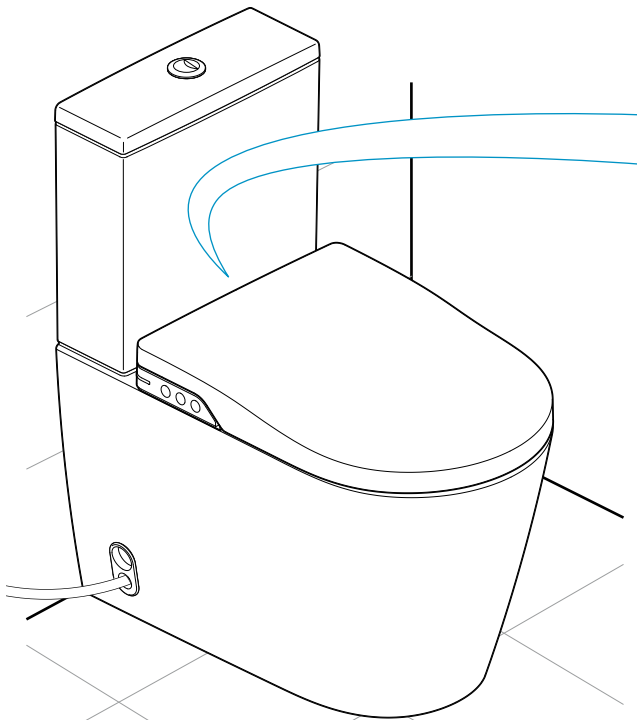

1

2

3

21

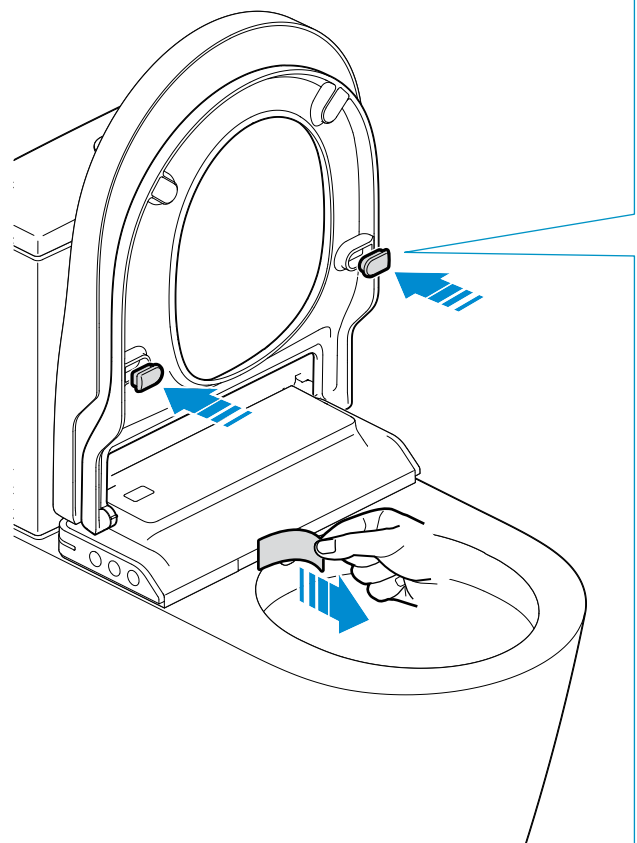

A **B** **C**

X = 2mm X = 3mm X = 4mm

Max. 1mm

22

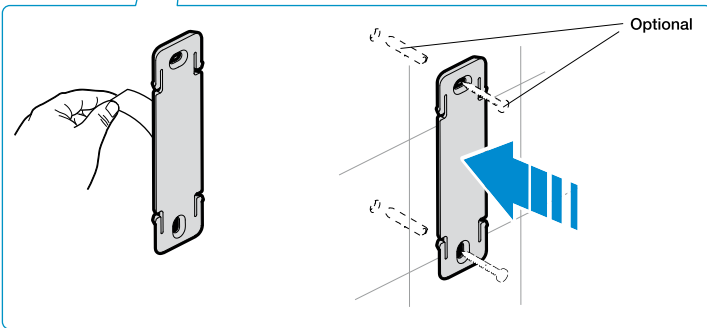
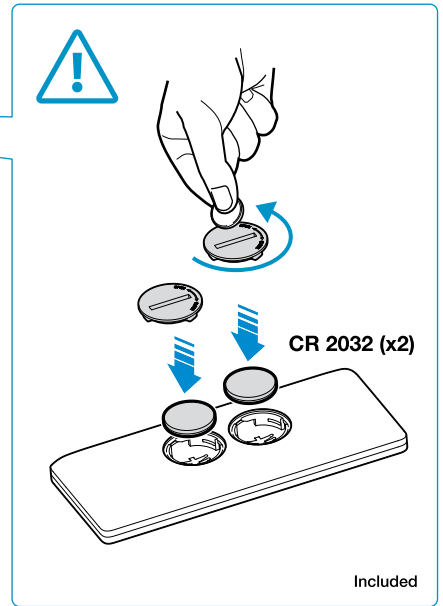
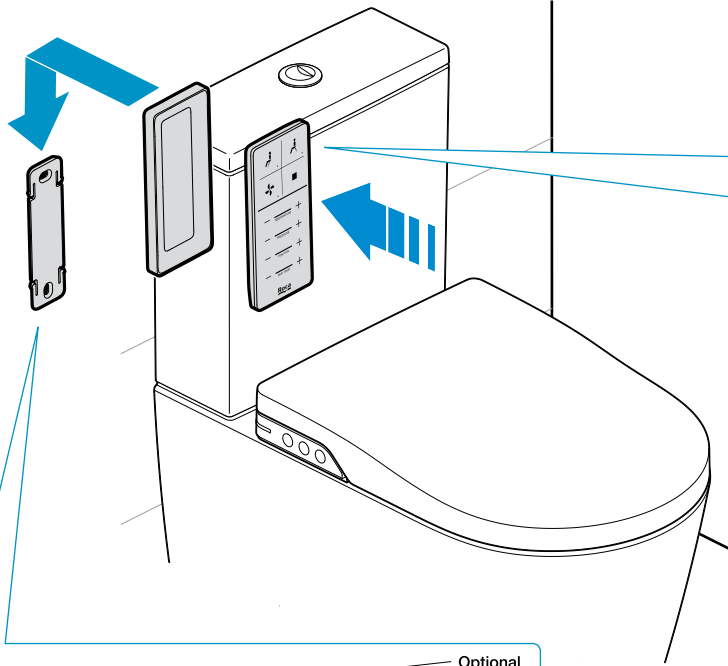

23

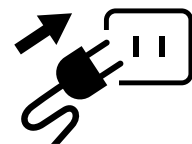
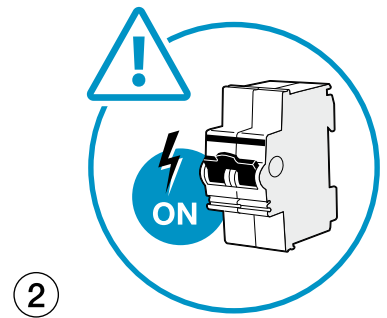
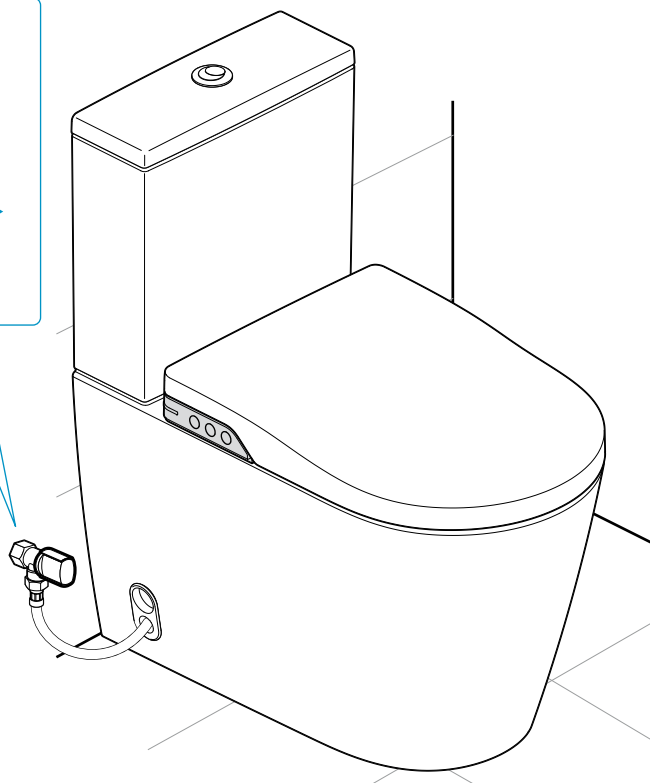
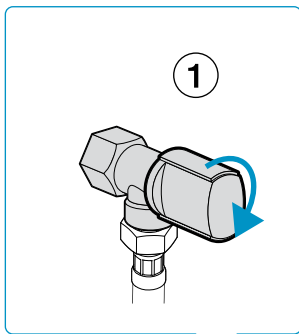

24

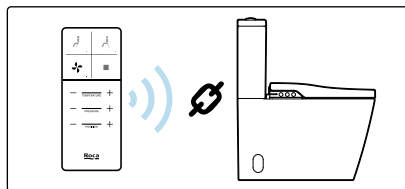

<p>1 OPEN</p>	<p>2 POWER</p> <p>ON</p>	<p>3 CONNECT</p> <p>Max. 60 s.</p> <p>5 s.</p>	<p>4 AUTO-TEST</p> <p>120 s.</p>
----------------------	--	---	---

After connecting the power (2), you have 60 seconds to link the remote control.

To link the remote control (3), press the *Stop* button on the remote control for 5 seconds. A beep will be heard and all the LEDs on the remote light up, as a signal that it is connected.

A self-calibration process starts for 120 seconds (4) during which water flows from the e-bidet nozzle window.

25

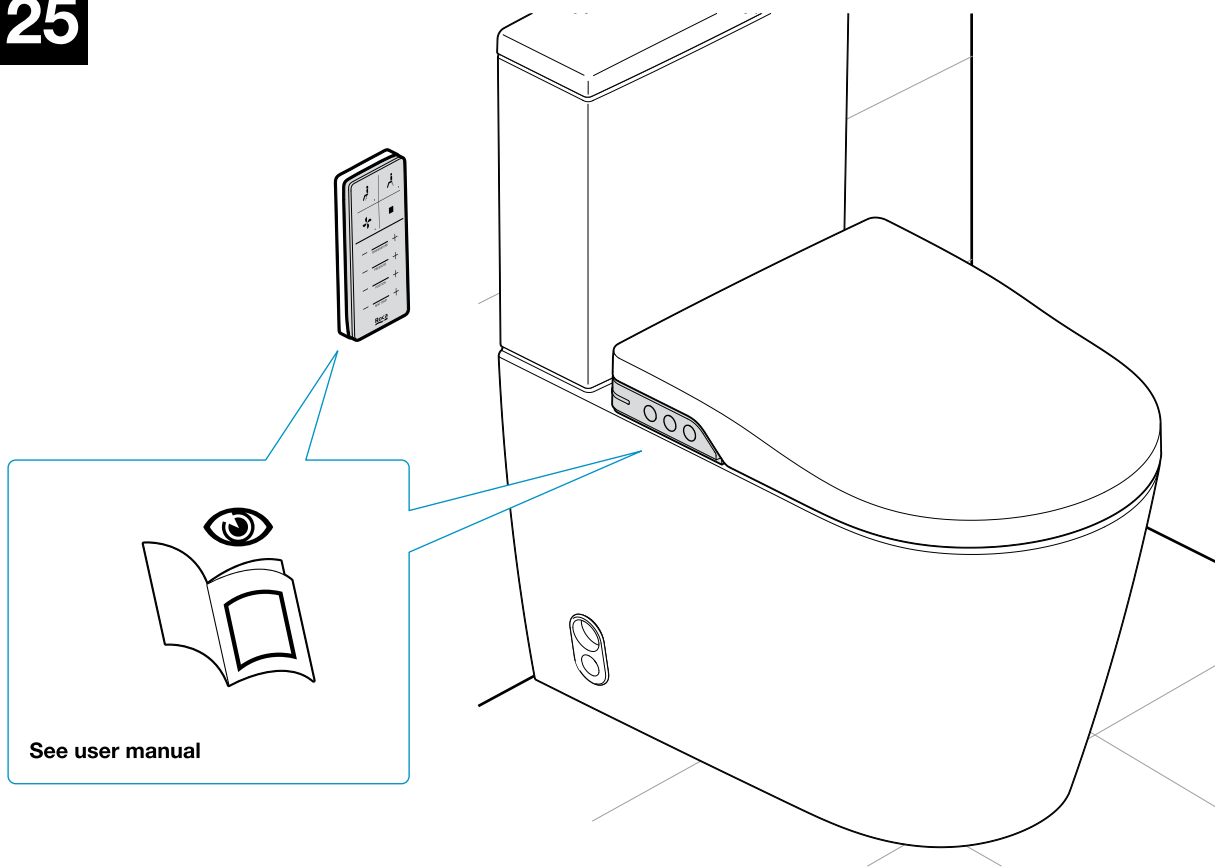

A8070S110Ra